

EE 202-(132)

HW4

Dr. Alakhdhar

Due 30/3/2014

Q1

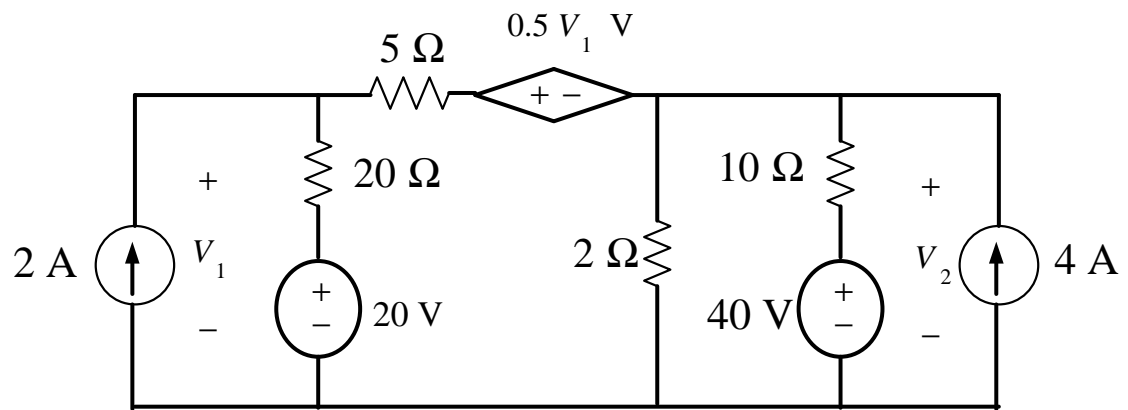

Use **Source Transformation** to find V_1 and V_2 ?

Q2

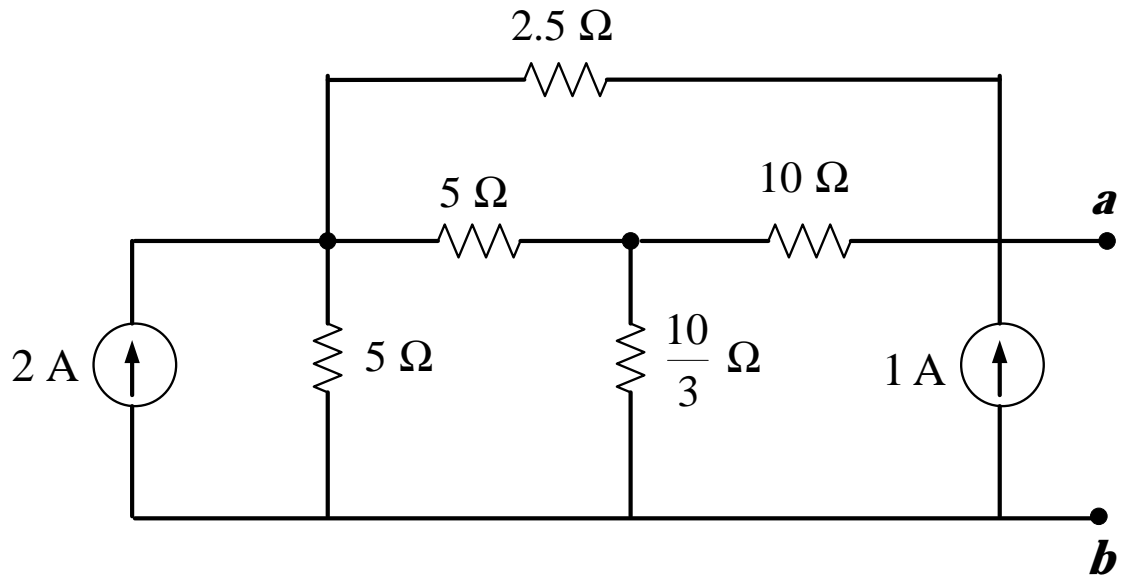

- Find the **Thevenin equivalent** circuit between **a** and **b** ?
- What is the value of the load that when connected between **a** and **b** will absorb **maximum power** ?
- what is the maximum power for the load in part (b) ?

Q3

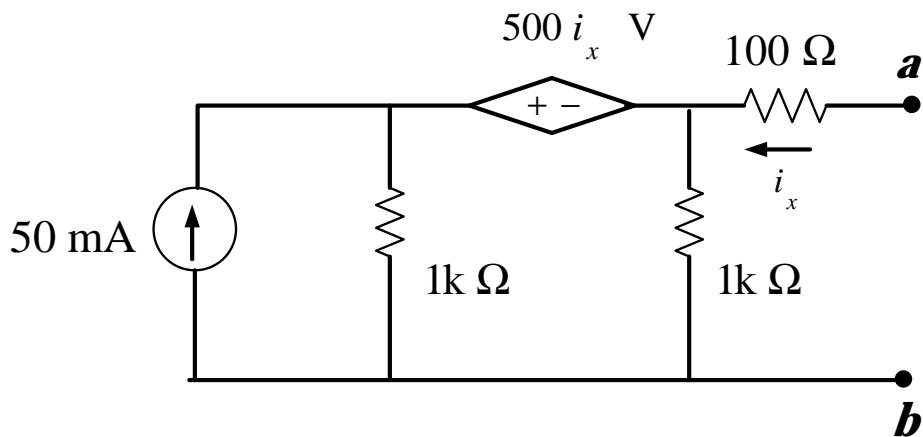

Find the **Norton equivalent** between **a** and **b** using (Find the short circuit current directly) ?

Q4

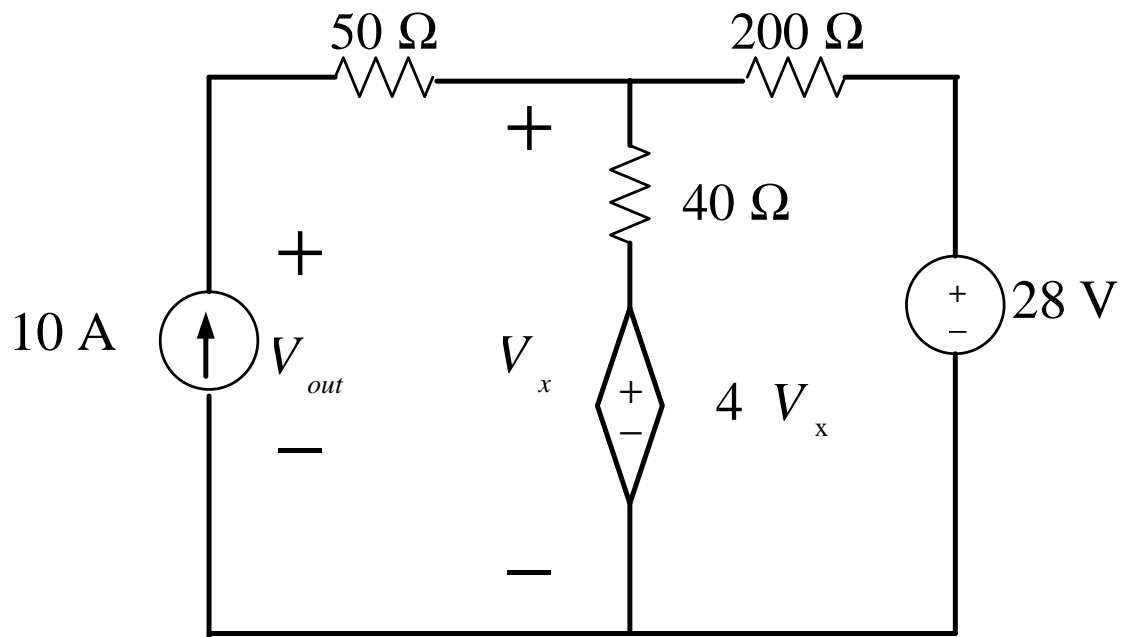

Use the principle of **superposition** to find V_{out} ?