

# **King Fahd University of Petroleum & Minerals Computer Engineering Dept**

---

**COE 540 –Computer Networks  
Term 081  
Dr. Ashraf S. Hasan Mahmoud  
Rm 22-148-3  
Ext. 1724  
Email: ashraf@kfupm.edu.sa**

10/13/2008

Dr. Ashraf S. Hasan Mahmoud

1

## **Lecture Contents**

---

1. Historical Overview
2. Messages and Switching
3. Layering
  - a. The OSI model
  - b. The TCP/IP model

10/13/2008

Dr. Ashraf S. Hasan Mahmoud

2

## Reading Assignment

---

- You are required to read the following chapters:
  - Chapter 1 of Gallager's textbook
  - Chapter 1 of Kurose's textbook
- The material is an overview of the field and serves as very "*basic*" introductory text.
- The material is required for subsequent quizzes and exam

10/13/2008

Dr. Ashraf S. Hasan Mahmoud

3

## Historical Overview

---

- Forms of data networks
  - Smoke signals - ?
  - Telegraphy – 19s century
- Very primitive – manual "signal" encoding

10/13/2008

Dr. Ashraf S. Hasan Mahmoud

4

## Historical Overview (2)

- Time-shared Processors
  - 1950s
  - Proliferation of communication links
  - Peripheral devices (printers, terminals, etc.) connect to the "expensive" CPU.

- Note that the central CPU is also managing the communication links!

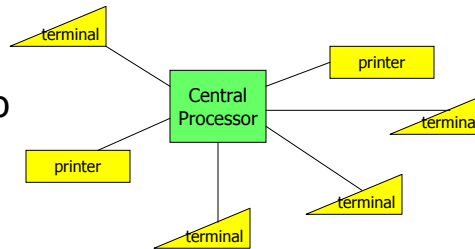

10/13/2008

Dr. Ashraf S. Hasan Mahmoud

5

## Historical Overview (3)

- Time-shared Processors – cont'd
- To relief the processor – a specialized "front end" processor is attached to the central processor to handle all communications

- Centralized system!

- Note the central processor is still at the center of the network

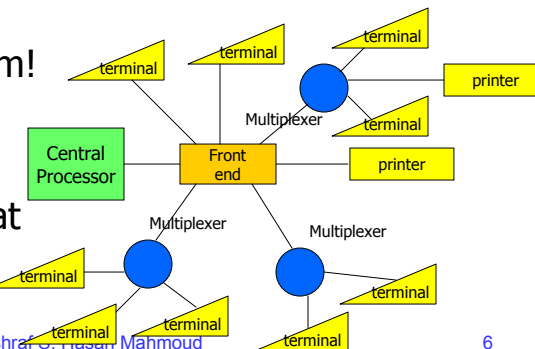

10/13/2008

Dr. Ashraf S. Hasan Mahmoud

6

## Historical Overview (4)

- ARPANET and TYMNET - ~70s
- General purpose data-networks
- Geographically distributed computer systems
- Interface Message Processors (IMPs) – computers specialized in routing messages
  - Routers/Switches
  - Connected using communication links
- Note, the “subnet” is now at the center of the network and not the shared computer

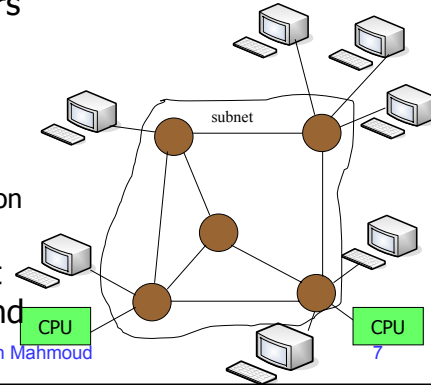

10/13/2008 Dr. Ashraf S. Hasan Mahmoud

## Historical Overview (5)

- Network of interconnected networks
- Explosive growth of wide area networks and local area networks
- The need for control algorithms or PROTOCOLs to handle data, gateways, bridges, etc.
- This shown network is similar to today's Internet!

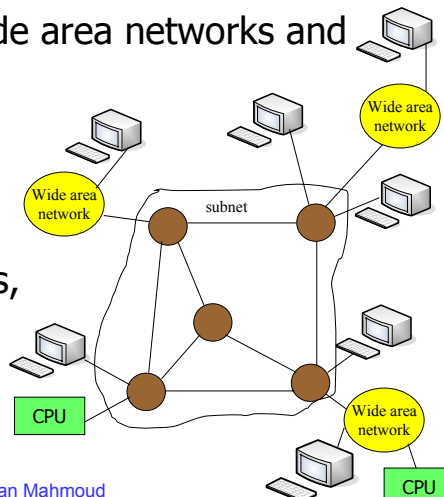

10/13/2008

Dr. Ashraf S. Hasan Mahmoud

## Historical Overview (6)

---

- What do think future networks will look like?
  - High speed (broadband)?
  - Integrated services: voice, data, multimedia, etc.
  - Quality of service (QoS) capable networks
  - Seamless services
  - Ubiquitous
  - Etc.

## Factors

---

- Technological and economy
  - Thanks to advances in VLSI, CPU prices are halved every six-to-twelve months with more processing power built in
  - Computers can do more – network has to cope
- Communication Technology
  - Evolution of link speeds: 2.4, 4.8, 9.6 and 56 kb/s
  - New links – 64 kb/s, 1.5 Mb/s, 45 Mb/s, etc.
  - Bandwidth sharing
  - Cost for media – TP versus optical
- Applications for data networks
  - Remote access of “super” computers – early
  - Email, FTP, HTTP – now (killer application?)
  - (distributed) database access
  - Etc.

## Messages and Switching

- What is a message? – give a definition
- Depend on the application/context
  - Email – document or file
  - Interactive system – transaction
- Representation of messages
  - String of bits
  - Compression – how?
- Is transferring long messages between network entities efficient? Why?
- Usually, long message are broken into “packets”
- The network must “switch” or direct packets to the destination

10/13/2008

Dr. Ashraf S. Hasan Mahmoud

11

## Exercise:

- Consider the simple network shown in figure. One file of  $K \gg 1$  bits must be sent from A to C. The file is decomposed into packets of  $P$  bits each. Each packet contains 16 error-control bits, 32 bits of address and sequence number, in addition to the  $P$  data bits. The transmission rate is  $R$  bits/sec. Each packet is first sent from A to B and then from B to C.
  - a) Find the value of  $P$  that minimizes the transmission time from A to C, neglecting the propagation time.
  - b) Repeat the problem when the file must go through  $N$  communication nodes between A and C.

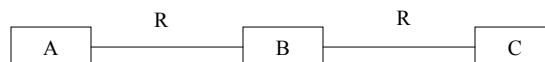

10/13/2008

Dr. Ashraf S. Hasan Mahmoud

12

## Sessions

---

- What is a session?
- Connection versus connectionless services
- Think of a “voice” session or an “HTTP” session
  
- What are the characteristics for connection-oriented communication?
- What are the characteristics for connectionless communication?
- Modeling of Traffic/Arrivals
  - Messages arrive at random points in time
  - Poisson process – approximations
  - Accuracy of model – voice (good), data (?)
  - On/Off models

important topic

10/13/2008

Dr. Ashraf S. Hasan Mahmoud

13

## Characteristics of Sessions

---

- Message arrival rate and variability of arrivals
- Session holding time
- Expected message length and length distribution
- Allowable delay
- Reliability
- Message and packet ordering

10/13/2008

Dr. Ashraf S. Hasan Mahmoud

14

## **Circuit Switching versus Store-and-Forward Switching**

---

- **Circuit switching:**
  - A dedicated path is established between two ends
  - Resources are reserved for session – justified when link utilization is expected to be high
  - Usually FDM, TDM, or CDMA based
  - Appropriate for CBR type traffic – rarely used for data
  - Eg. Telephony
  - Involves: call setup, data exchange, call termination
- **Store-and-Forward switching:**
  - The processing is done on the packet level
  - Intermediate nodes receive and process (switch) packets
  - Different packets may go different routes
  - No call setup
  - Resources are not reserved but utilized as required
  - Appropriate for VBR type traffic

10/13/2008

Dr. Ashraf S. Hasan Mahmoud

15

## **Taxonomy of Store-and-Forward**

---

- **Message switching** – messages sent as unit entities and not segmented into packets
  - Requires max message size
- **Packet switching** – messages are broken into packets (usually fixed length)
  - Same as store-and-forward
- **Virtual circuit routing** – path is setup when session is initiated; maintained for the life of the session (i.e. all packets follow same path)
- **Dynamic (datagram) routing** – every packet on its own

10/13/2008

Dr. Ashraf S. Hasan Mahmoud

16



# Link Utilization

More on this topic to be covered when queueing theory is discussed.

- Variables of interest:
  - $t_1, t_2, t_3, \dots$  : interarrival times
  - $X_1, X_2, X_3, \dots$  : message duration
- Arrival rate,  $\lambda = E[t_i]$
- Link utilization,  $\rho = \lambda E[X_i] = E[X_i]/E[t_i]$ 
  - $\rho \ll 1 \rightarrow$  low utilization,
  - $\rho = 1 \rightarrow$  100% utilization
  - $\rho > 1 \rightarrow$  unstable link/system

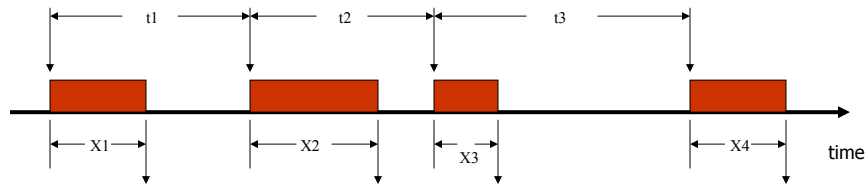

10/13/2008

Dr. Ashraf S. Hasan Mahmoud

17

# The Concept of Layering

- Source: [http://en.wikipedia.org/wiki/OSI\\_model](http://en.wikipedia.org/wiki/OSI_model)

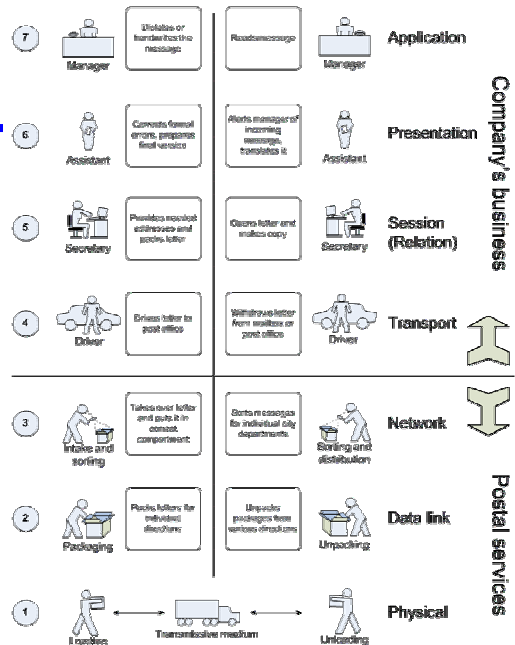

10/13/2008

Dr. Ashraf

RM – OSI and letter communication parallel

## Protocols - Definition

- **What is a Protocol:**
  - Convention between two communicating entities governing exchange of data
- **Elements of Protocol:**
  - **Syntax:** data format, signal levels, etc.
  - **Semantics:** control info coordination and error handling
  - **Timing:** matching speeds and sequencing (synchronization)
- **What is a "communicating entity"?**
  - Node,
  - Module,
  - Process,
  - Etc.

10/13/2008

Dr. Ashraf S. Hasan Mahmoud

19

## The OSI Model - Environment

- Layer i establishes a PEER relationship with layer i on the target node
- This means Layer i requires service from layer i-1
- And so on
- The use of the PDUs
- No direct communication except for the physical layer – all other communication is indirect or virtual
- Encapsulation of user data
- Each layer may segment SDU to accommodate its own requirement – These are reassembled at the other end

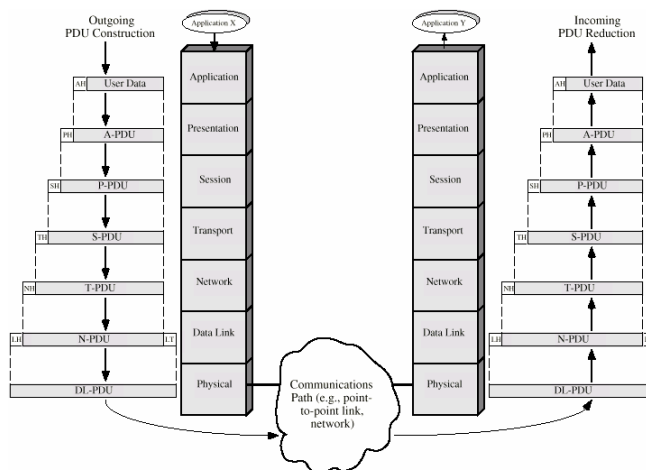

10/13/2008

Dr. Ashraf S. Hasan Mahmoud

20

# The OSI Model - Framework

- Very similar to subroutine or function design in software engineering
- Boundaries and functionalities are well designed – development of one layer has little or no effect on other layers
- Protocol specification:
  - Format of PDUs, and the semantic of each field
- Service definition:
  - What are the services provided to upper layer and the lower one
- Addressing:
  - E.g: NSAP is the address of an entity in the transport layer who uses the network service

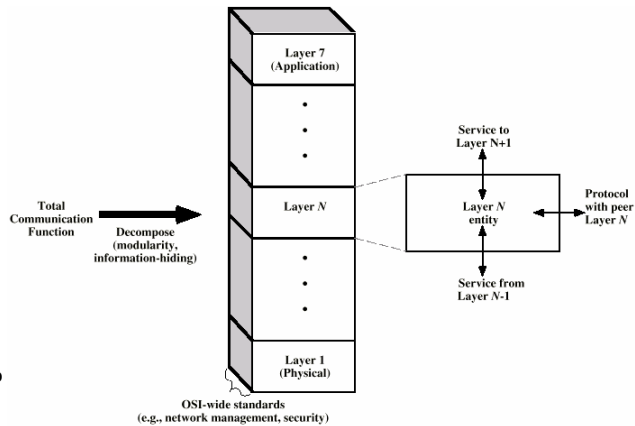

10/13/2008

Dr. Ashraf S. Hasan Mahmoud

21

# The OSI Model - Framework

- Service Primitives:
  - Request:
  - Indication:
  - Respond
  - Confirm
- Note:
  - Encapsulation
  - Peer communication is virtual (dashed lines) – except at physical layer
  - Figure shows confirmed services case – For non confirmed services, the initiator receives no confirmation.

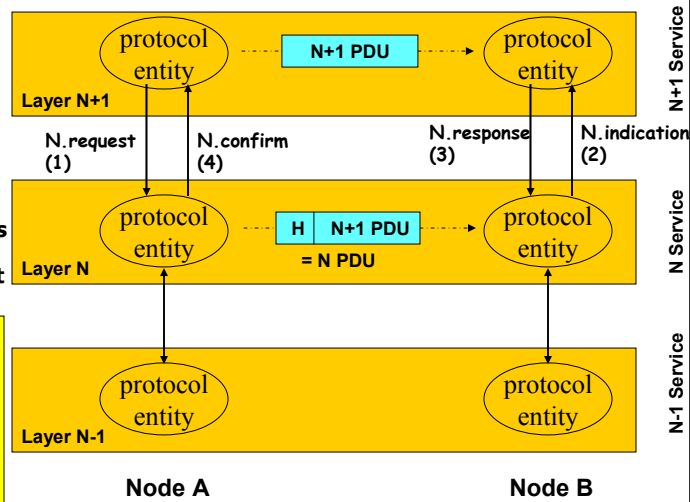

10/13/2008

Dr. Ashraf S. Hasan Mahmoud

22

## Layering and Packet Headers

- The example is NOT showing OSI layers – but some hypothetical system of (Application, Transport, Network, Data Link Control, and Physical Layer)

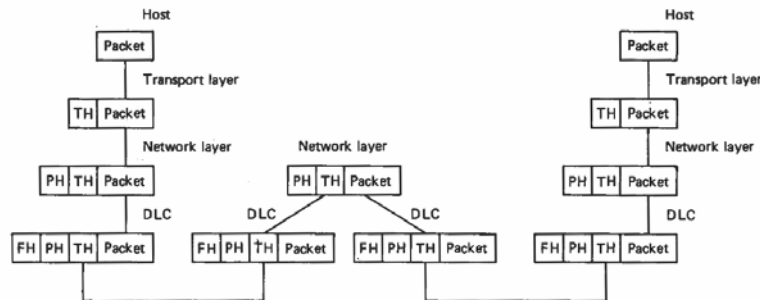

Figure 1.12 Illustration of various headers on a frame. Note that each layer looks only at its own header.

10/13/2008

Dr. Ashraf S. Hasan Mahmoud

23

## The OSI Model – Physical Layer

- **Specifications:**
  - **Mechanical:** dimensions, connectors, etc.
  - **Electrical:** signal levels, rates of change, etc
  - **Functional:** functions performed by each circuit
  - **Procedural:** steps required to transport bits from one end to the other
- **Provides service to do “transmission of raw bits”**

10/13/2008

Dr. Ashraf S. Hasan Mahmoud

24

## The OSI Model – Data Link Layer

- **Coverts the raw bit stream service provided by the physical layer to a reliable stream:**
  - Performs error detection and error control
- **Examples: HDLC, LAPB, LLC, etc**

10/13/2008

Dr. Ashraf S. Hasan Mahmoud

25

## The OSI Model – Network Layer

- **Service: transfer of information between two end systems across communication network – End to end delivery of packets**

- **Two end systems may be connected by:**
  - **Point-2-point: no need for network layer**
  - **Same network (see figure)**
  - **Different network**

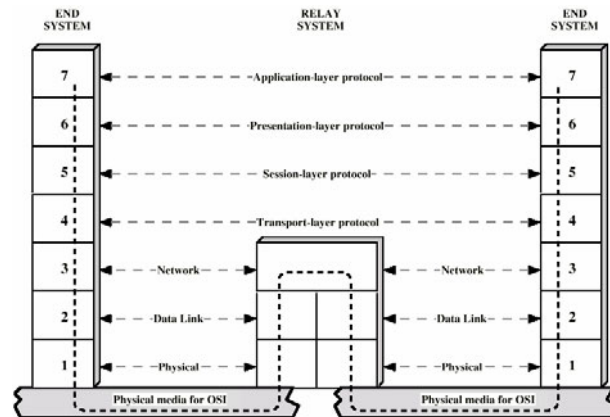

10/13/2008

## **The OSI Model – Transport Layer**

---

- **Service: mechanism of exchanging data (or messages) between the two end systems:**
  - For connection oriented networks:
    - Error-free delivery
    - Ordered delivery
    - No loss or duplication
    - Attempts to provide a certain quality of service (QoS) {certain max error rate, delay jitter, etc) through optimizing the the network layer services
- **Example: TCP (connection oriented), UDP (connectionless)**

10/13/2008

Dr. Ashraf S. Hasan Mahmoud

27

## **The OSI Model – Session Layer**

---

- **Service: mechanism of controlling the dialogue between applications at end systems**
  - Dialogue Discipline
  - Grouping
  - Recovery

10/13/2008

Dr. Ashraf S. Hasan Mahmoud

28

## **The OSI Model – Presentation**

---

- **Service: defines format of data (format, encryption, and compression) to be exchanged between applications**

## **The OSI Model – Application**

---

- **Service: A means for user applications (email, ftp, etc) to access the services provided by the OSI model**

## **The TCP/IP Model**

---

- **TCP/IP is the result of R&D conducted on experimental packet switched network (ARPANET) and funded by Defense Advanced Research Agency (DARPA)**
- **TCP/IP is NOW the dominant commercial architecture – The foundation of the internet and its applications**

10/13/2008

Dr. Ashraf S. Hasan Mahmoud

31

## **The TCP/IP Model**

---

- **Model has five independent layers:**
  - **Application layer: comm between processes or applications on separate hosts**
  - **Transport layer: end-2-end transfer service – may include reliability mechanisms**
  - **Internet layer: routing data from source to destination through one or more networks**
  - **Network access layer: logical interface between end systems and the network**
  - **Physical layer: defines mechanism of transmitting raw bits depending on media characteristic**

10/13/2008

Dr. Ashraf S. Hasan Mahmoud

32



## The TCP/IP Model (using the OSI Model as a reference)

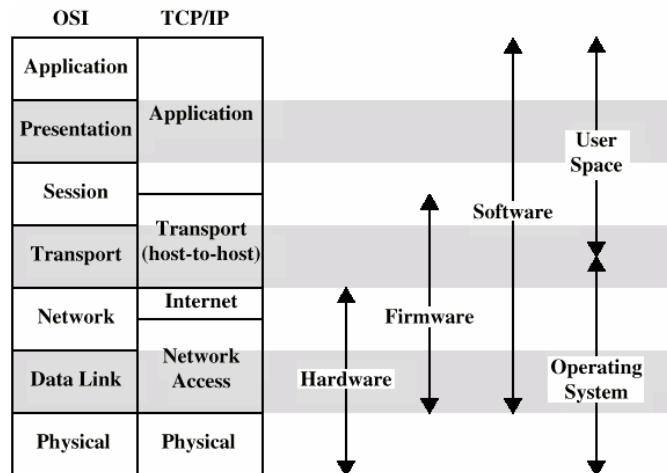

10/13/2008

Dr. Ashraf S. Hasan Mahmoud

33

## Example of TCP/IP Communications

- A process (has port 1) on host A needs to communicate to another process: port 2 at host B
- The application layer on A hands the msg down to TCP with instructions to deliver it to (port2,host B)
- TCP hands msg down to IP with instructions to send it to host B:
  - The IP layer knows how to reach host B (or at least the first hop of the route) – does not care about port info
- IP hands down packets to network access (say Ethernet) with instructions to pass it to next router (first hop on the way to B)

10/13/2008

Dr. Ashraf S. Hasan Mahmoud

34

## Example of TCP/IP Communications

- Does not show segmentation (or fragmentation in IP terms) process!

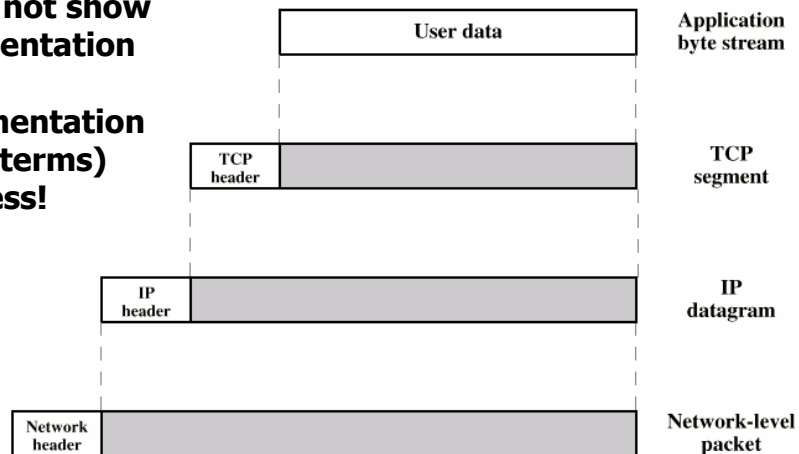

10/13/2008

Dr. Ashraf S. Hasan Mahmoud

35

## TCP/IP Control Information (Partial)

- **TCP control info:**
  - Destination port number
  - Sequence number
  - Checksum
- **IP control info:**
  - IP address
- **Network Access control info:**
  - Destination network access address (this is not the IP!!)
  - Facilities request (e.g. priorities)

10/13/2008

Dr. Ashraf S. Hasan Mahmoud

36

# TCP/IP Control Information (Partial)

