

Q1.

One end of a stretched string vibrates with a period of 1.5 s. This results in a wave propagating at a speed of 8.0 m/s along the string. What is the wavelength, in m, of the wave that travel along the string?

- A) 12
- B) 10
- C) 3.0
- D) 8.0
- E) 1.5

---

Q2.

A pipe has two consecutive resonance frequencies of 220 Hz and 260 Hz. One end of the pipe is closed. What is the fundamental frequency of the pipe?

- A) 20 Hz
- B) 30 Hz
- C) 40 Hz
- D) 60 Hz
- E) 80 Hz

---

Q3.

At what temperature is the Fahrenheit scale reading equal to half that of the Celsius scale?

- A)  $-12.3\text{ }^{\circ}\text{F}$
- B)  $+23.4\text{ }^{\circ}\text{F}$
- C)  $-230\text{ }^{\circ}\text{F}$
- D)  $-40.0\text{ }^{\circ}\text{F}$
- E)  $+32.0\text{ }^{\circ}\text{F}$

---

Q4.

A  $0.050\text{-m}^3$  container has 5.00 moles of argon gas at a pressure of 1.00 atm. What is the rms speed of the argon molecules? ( $M_{\text{Ar}} = 40.0\text{ g/mole}$ )

- A) 275 m/s
- B) 496 m/s
- C) 398 m/s
- D) 940 m/s
- E) 870 m/s

Q5.

At very low temperatures, the molar specific heat  $C$  of aluminum is given by the relation  $C = AT^3$ , where  $A = 3.15 \times 10^{-5} \text{ J}/(\text{mol}\cdot\text{K}^4)$ . Find the entropy change for 4.00 mol of aluminum when its temperature is raised from 5.00 K to 10.0 K.

- A) 0.0368 J/K
- B) 0.0442 J/K
- C) 0.1260 J/K
- D) 0.0184 J/K
- E) 0.0034 J/K

Q6.

Two identical conducting spheres, each having a radius of 0.500 cm, are connected by a light 2.00-m-long conducting wire. A charge of  $60.0 \mu\text{C}$  is placed on one of the conductors. Assume that the surface distribution of charge on each sphere is uniform. Determine the tension in the wire.

- A) 2.00 N
- B) 3.00 N
- C) 1.00 N
- D) 0.50 N
- E) 6.00 N

Q7.

**Figure 1** shows two concentric conducting shells of radii ( $R_1=2.0 \text{ cm}$ ) and ( $R_2=6.0 \text{ cm}$ ). The smaller (inner) shell has a net positive charge ( $+q$ ) and the larger (outer) shell has a net charge of magnitude  $Q$ . If the electric potential on the inner shell ( $r = R_1$ ) is zero, what is the value of the ratio  $Q/q$ ?

Fig#

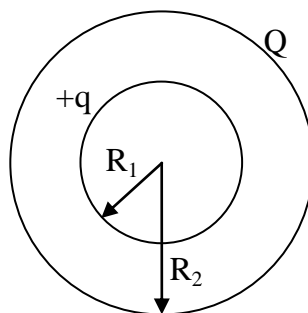

- A) - 3.0
- B) - 0.33
- C) + 3.0
- D) + 0.33
- E) - 9.0

Q8.

In xy-plane, the electric potential depends on  $x$  and  $y$  as shown in **Figure 2** (the potential does not depend on  $z$ ). The electric field in this region is:

[  $\hat{i}$  and  $\hat{j}$  are the unit vectors in  $x$  and  $y$  direction, respectively]

Fig#

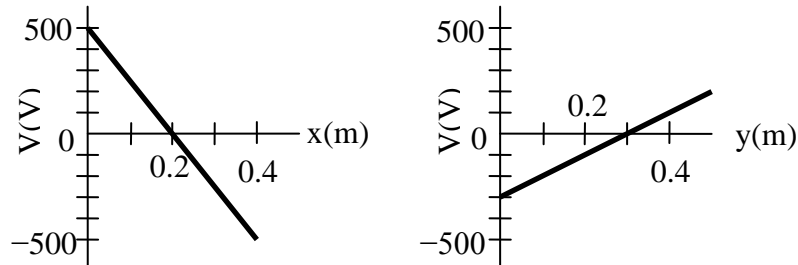

- A)  $(+2500 \hat{i} - 1000 \hat{j})$  V/m
- B)  $(+500 \hat{i} - 500 \hat{j})$  V/m
- C)  $(-500 \hat{i} + 1000 \hat{j})$  V/m
- D)  $(-500 \hat{i} + 500 \hat{j})$  V/m
- E)  $(+5000 \hat{i} - 2000 \hat{j})$  V/m

Q9.

If we make two conducting spheres to touch each other (see **Figure 3**), then find the final charges of the spheres.

Fig#

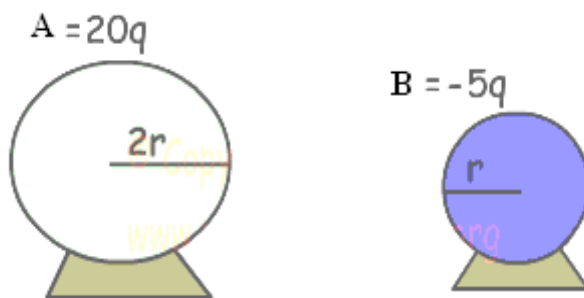

- A)  $A = +10q, B = +5q$
- B)  $A = +15q, B = +5q$
- C)  $A = -5q, B = +20q$
- D)  $A = -10q, B = +5q$
- E)  $A = -5q, B = -5q$

Q10.

A 500-nF capacitor,  $C_1$ , is fully charged by a 120-V power supply, then disconnected. Next, the capacitor  $C_1$  is connected to an initially uncharged capacitor  $C_2$ . Find the capacitance of  $C_2$  if the potential difference across it is found to be 50.0 V.

- A) 700 nF.
- B) 170 nF.
- C) 210 nF.
- D) 480 nF.
- E) 600  $\mu$ F.

Q11.

In **Figure 4**, the currents  $I_1$  and  $I_2$  are 0.14 A and 2.22 A, respectively, what is the potential difference  $V_a - V_b$ ?

Fig#

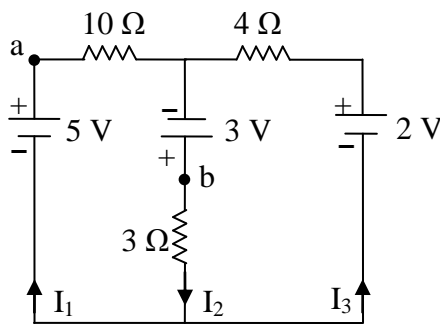

- A) -1.6 V
- B) 0 V
- C) +3.0 V
- D) -3.0 V
- E) +1.6 V

Q12.

In **Figure 5**, find the resistance R,

Fig#

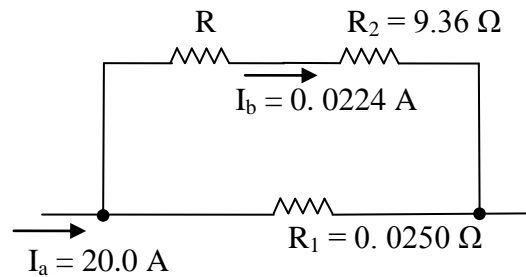

- A) 12.9  $\Omega$
- B) 10.0  $\Omega$
- C) 16.2  $\Omega$
- D) 14.3  $\Omega$
- E) 18.8  $\Omega$

Q13.

What value of R will make  $V_2 = V_1/10$  in the circuit in **Figure 6**?

Fig#

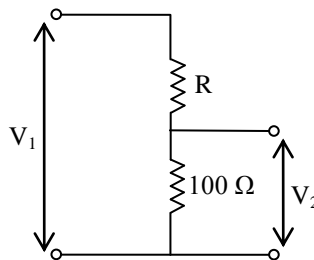

- A) 900  $\Omega$
- B) 200  $\Omega$
- C) 100  $\Omega$
- D) 700  $\Omega$
- E) 500  $\Omega$

Q14.

Three identical resistors are connected in series. When a certain potential difference is applied across the combination, the total power dissipated is 36.0 W. What power would be dissipated if the three resistors were connected in parallel across the same potential difference?

- A) 324 W
- B) 124 W
- C) 36.0 W
- D) 6.00 W
- E) 423 W

Q15.

In the circuit shown in **Figure 7**, the  $33\Omega$  resistor dissipates  $0.50\text{ W}$ . What is the emf of the ideal battery?

Fig#

- A)  $8.5\text{ V}$
- B)  $7.1\text{ V}$
- C)  $3.5\text{ V}$
- D)  $1.3\text{ V}$
- E)  $5.9\text{ V}$

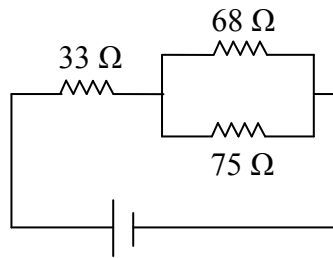

Q16.

A charged capacitor, with potential difference  $12.0\text{ V}$  is connected to a voltmeter having an internal resistance of  $3.4 \times 10^6\ \Omega$ . After a time of  $4.0\text{ s}$  the voltmeter reads  $3.0\text{ V}$ . What is the capacitance of the capacitor?

- A)  $8.5 \times 10^{-7}\text{ F}$
- B)  $3.4 \times 10^{-7}\text{ F}$
- C)  $2.8 \times 10^{-4}\text{ F}$
- D)  $6.3 \times 10^{-4}\text{ F}$
- E)  $1.2 \times 10^{-4}\text{ F}$

Q17.

**Figure 8** shows a region where there is a uniform electric field and a uniform magnetic field normal to each other. A proton is moving to the left with speed “ $v$ ” in the plane of the page. If  $v$  is increased in such a way that  $v > E/B$ , the proton will (Neglect the gravity)

Fig#

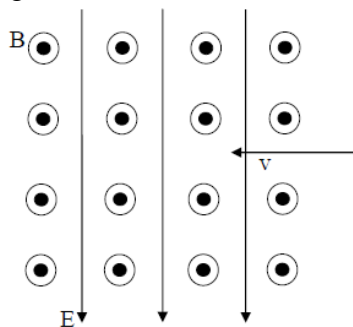

- A) stay in the plane of the page and deflect upward
- B) undergo no deflection
- C) deflect out of the plane of the page
- D) stay in the plane of the page and deflect downward
- E) stop

Q18.

**Figure 9** shows an electron entering a magnetic field with a speed of  $5.5 \times 10^6$  m/s. The magnetic field has a magnitude of 0.75 T. Calculate the radius of the electron's circular path, in micro-meter.

Fig#

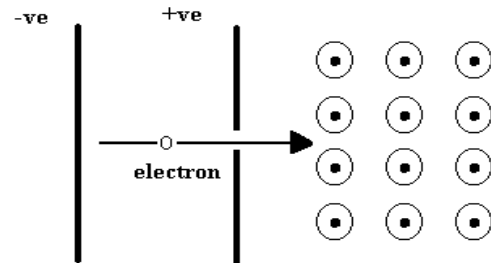

- A) 42
- B) 53
- C) 82
- D) 11
- E) 19

Q19.

A square loop of wire lies in the plane of the page and carries a current  $I$  as shown in **Figure 10**. There is a uniform magnetic field  $\vec{B}$  directed towards the top of the page, as indicated. The loop will tend to rotate:

Fig#

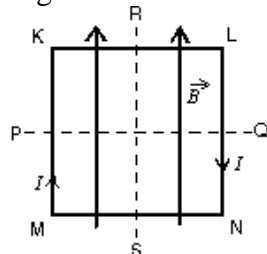

- A) about PQ with KL coming out of the page
- B) about PQ with KL going into the page
- C) about RS with MK coming out of the page
- D) about RS with MK going into the page
- E) about an axis perpendicular to the page

Q20.

A loop of current-carrying wire has a magnetic dipole moment of  $5.0 \times 10^{-4}$  A.m<sup>2</sup>. If the dipole moment makes an angle of  $57^\circ$  with a magnetic field of 0.35 T, what is its orientation energy?

- A)  $-9.5 \times 10^{-5}$  J
- B)  $-1.5 \times 10^{-4}$  J
- C)  $-1.8 \times 10^{-4}$  J
- D)  $+1.5 \times 10^{-4}$  J
- E)  $+9.5 \times 10^{-5}$  J

Q21.

A rectangular current carrying loop is shown in **Figure 11** beside a long straight current carrying wire. Which one of the following statements could be responsible for the current direction shown in the loop?

Fig#

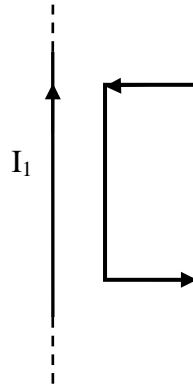

- A) The loop is moving to the left
- B) The loop is moving to the right
- C) The loop is moving up the page
- D) The loop is moving down the page
- E) The loop must remain motionless

Q22.

Two concentric circular loops of wire of radii  $a = 2.0$  cm and  $b = 4.0$  cm each carries a current  $I = 5.00$  A in the directions indicated in **Figure 12**. What is the magnetic field at center P?

Fig#

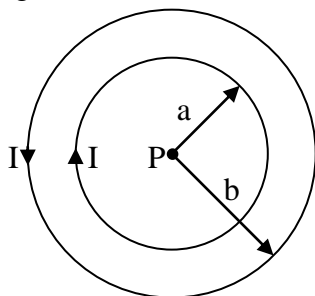

- A)  $78.5 \mu\text{T}$  into the page
- B)  $78.5 \mu\text{T}$  out of the page
- C)  $29.3 \mu\text{T}$  into the page
- D)  $29.3 \mu\text{T}$  out of the page
- E)  $0.60 \mu\text{T}$  into the page



Q23.

Solenoid 2 has four times the radius and twice the number of turns per unit length as solenoid 1. Find the ratio of the magnitude of the magnetic field in the interior of solenoid 2 to that in the interior of solenoid 1, if the two solenoids carry the same current.

- A) 2
- B) 4
- C) 6
- D) 1
- E) 1/3

Q24.

Two long straight wires penetrate, normally, the plane of the paper at two vertices of an equilateral triangle as shown in **Figure 13**. They each carry 3.0 A, out of the page. The magnetic field at the third vertex (P) has magnitude (in T):

Fig#

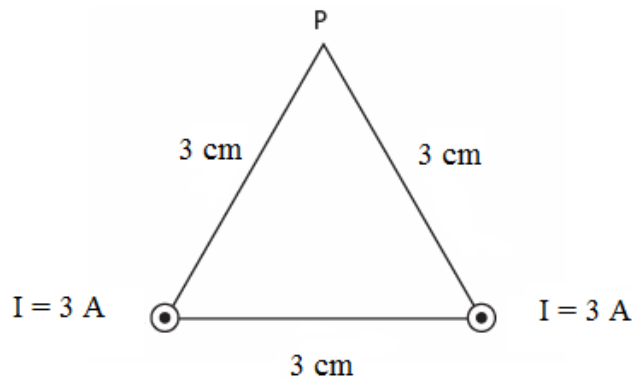

- A)  $3.5 \times 10^{-5}$
- B)  $2.0 \times 10^{-4}$
- C) 0
- D)  $3.5 \times 10^{-7}$
- E)  $8.7 \times 10^{-6}$

Q25.

A long wire has a radius  $R > 4.0\text{ mm}$  and carries a current that is uniformly distributed over its cross section. The magnitude of the magnetic field due to this current is 0.28 mT at a point 4.0 mm from the axis of the wire, and 0.20 mT at a point outside the wire and at 10 mm from the axis of the wire. What is the radius R of the wire?

- A) 5.3 mm
- B) 6.0 mm
- C) 7.5 mm
- D) 8.0 mm
- E) 4.6 mm

Q26.

A current loop, carrying a current of 2.0 A, is in the shape of a right angle triangle with sides 0.5, 0.5, and 0.7 m as shown in **Figure 14**. The loop is in a uniform magnetic field of magnitude 120 mT whose direction is parallel to the current in the 0.7 m side of the loop. Find the magnitude of the torque, in N.m, on the loop.

Fig#

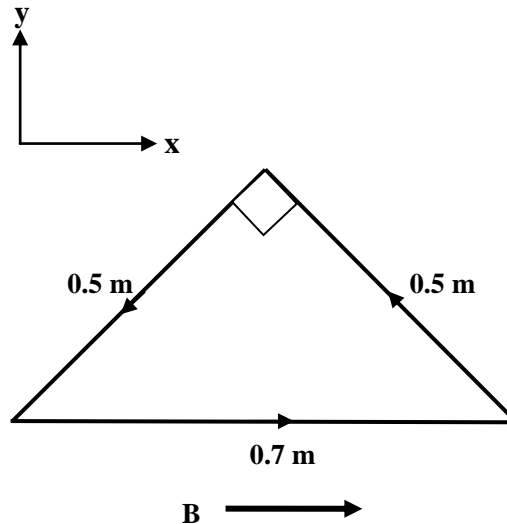

- A) 0.03
- B) 12
- C) 24
- D) 0.06
- E) 0

Q27.

A uniform magnetic field  $B = 2.0$  T makes an angle of  $30^\circ$  with the  $z$  – axis. The magnitude of the magnetic flux through a  $3.0$  m<sup>2</sup> portion of the  $x$ - $y$  plane is:

- A) 5.2 Wb
- B) 2.0 Wb
- C) 3.0 Wb
- D) 6.0 Wb
- E) 9.0 Wb

Q28.

The plane of a rectangular coil of dimensions 5.0 cm by 8.0 cm is perpendicular to the direction of a magnetic field  $\vec{B}$ . If the coil has 75 turns and a total resistance of  $8.0 \Omega$ , at what rate must the magnitude of  $\vec{B}$  change in order to induce a current of 0.10 A in the windings of the coil?

- A) 2.67 T/s
- B) 3.33 T/s
- C) 0.63 T/s
- D) 1.45 T/s
- E) 8.32 T/s

Q29.

The graph (in **Figure 15**) gives the magnitude  $B(t)$  of a uniform magnetic field that exists throughout a conducting loop, with the direction of the field perpendicular to the plane of the loop. Rank the four regions of the graph according to the magnitude of the emf induced in the loop, smallest first.

Fig#

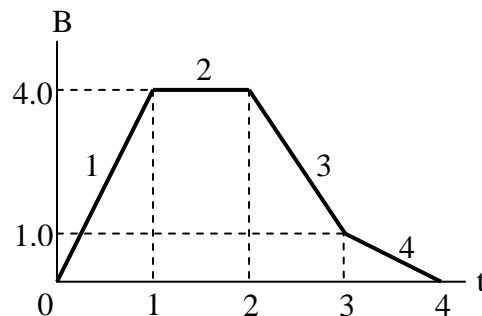

- A) 2, 4, 3, 1
- B) 1, 3, 4, 2
- C) 1, 2, 3, 4
- D) 4, 3, 1, 2
- E) 4, 3, 2, 1

---

Q30.

A 20.0 m long copper wire, with a resistance of  $10.0 \Omega$ , is formed into a circular loop (single turn) and placed with its plane perpendicular to an external magnetic field that is increasing at the constant rate of  $5.00 \text{ mT/s}$ . At what rate is thermal energy generated in the loop?

- A) 2.53 mW
  - B) 3.20 mW
  - C) 4.35 mW
  - D) 1.50 mW
  - E) 10.0 mW
-