

Q1.

A water molecule (H_2O) consists of an oxygen (O) atom of mass $16m$ and two hydrogen (H) atoms, each of mass m , bound to it (see **Figure 1**). The angle between the two bonds is 106° . The length of each bond is 0.100 nm . What is the center of mass (x_{com} and y_{com}) of the molecule?

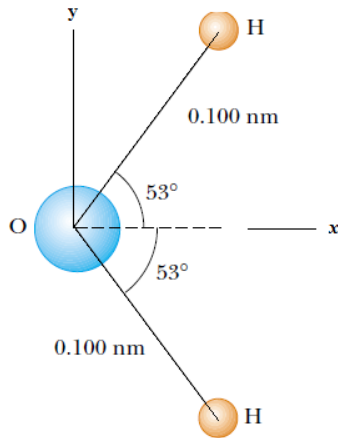

- A) $x_{com} = 0.007 \text{ nm}$, $y_{com} = 0.0 \text{ nm}$
 B) $x_{com} = 0.009 \text{ nm}$, $y_{com} = 0.0 \text{ nm}$
 C) $x_{com} = 0.0 \text{ nm}$, $y_{com} = 0.0 \text{ nm}$
 D) $x_{com} = 0.0 \text{ nm}$, $y_{com} = 0.009 \text{ nm}$
 E) $x_{com} = 0.007 \text{ nm}$, $y_{com} = 0.009 \text{ nm}$

Q2.

0.40-kg ball, moving horizontally to the right with a speed 30 m/s , hits a vertical wall and rebounds horizontally to the left with a speed 20 m/s . The contact time of the ball with the wall is 0.010 s . Find the average force that the wall exerts on the ball during the impact.

- A) 2.0 kN to the left
 B) 0.40 kN to the left
 C) 2.0 kN to the right
 D) 3.9 kN to the left
 E) 0.40 kN to the right

Q3.

5.00-g bullet moving with an initial speed of 400 m/s is fired into and passes through a 1.00-kg block, as shown in **Figure 2**. The block, initially at rest on a frictionless, horizontal surface, is connected to a spring with force constant 900 N/m . If the block moves a maximum distance of 5.00 cm to the right after impact, what is the speed at which the bullet emerges from the block? (Neglect the time spent by the bullet inside the block)

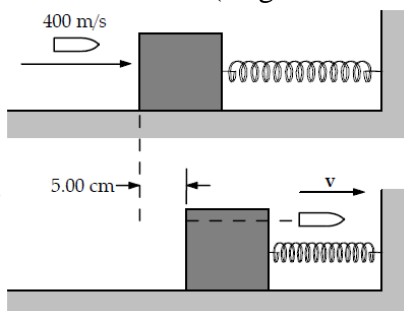

- A) 100 m/s
 - B) 200 m/s
 - C) 300 m/s
 - D) 150 m/s
 - E) 399 m/s
-

Q4.

A collision occurs between a 2.00 kg particle traveling with velocity $\vec{v}_1 = (-4.00 \text{ m/s})\hat{i} + (-5.00 \text{ m/s})\hat{j}$ and a 4.00 kg particle traveling with velocity $\vec{v}_2 = (6.00 \text{ m/s})\hat{i} + (-2.00 \text{ m/s})\hat{j}$. The two particles stick together after collision. What is the velocity of the stuck-together particles just after collision?

- A) $(2.67 \text{ m/s})\hat{i} + (-3.00 \text{ m/s})\hat{j}$
 - B) $(-5.33 \text{ m/s})\hat{i} + (-0.33 \text{ m/s})\hat{j}$
 - C) $(5.33 \text{ m/s})\hat{i} + (0.33 \text{ m/s})\hat{j}$
 - D) $(-2.00 \text{ m/s})\hat{i} + (-7.00 \text{ m/s})\hat{j}$
 - E) $(10.0 \text{ m/s})\hat{i} + (3.00 \text{ m/s})\hat{j}$
-

Q5.

A car accelerates uniformly from rest and reaches a speed of 22.0 m/s in 9.00 s. If the diameter of the car's tire is 58.0 cm, what is the number of revolutions the tire makes during this time, assuming that no slipping occurs?

- A) 54.3 rev
 - B) 109 rev
 - C) 75.9 rev
 - D) 18.6 rev
 - E) 27.2 rev
-

Q6.

A uniform rod of length $L = 90 \text{ cm}$ and mass $M = 300 \text{ g}$ is free to rotate on a frictionless pin passing through one end, as shown in **Figure 3**. The rod is released from rest in the horizontal position. Determine the linear speed (v) of the lowest point of the rod when it is in the vertical position.

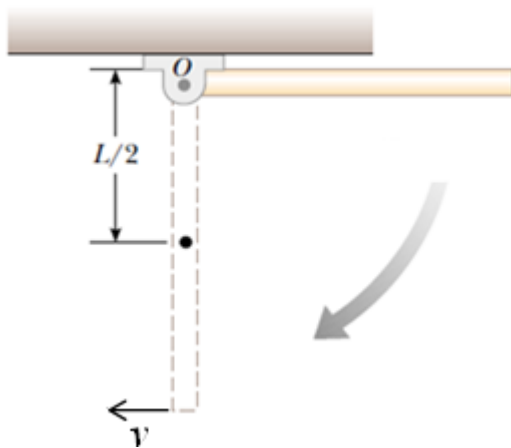

- A) 5.14 m/s
 B) 9.39 m/s
 C) 10.3 m/s
 D) 0.0 m/s
 E) 4.70 m/s

Q7.

In **Figure 4**, a wheel of radius 0.20 m is mounted on a frictionless horizontal axle. A massless cord is wrapped around the wheel and attached to a 2.0 kg box that slides on a frictionless surface inclined at angle $\theta = 20^\circ$ with the horizontal. The box accelerates down the surface at 2.0 m/s^2 . What is the rotational inertia of the wheel about the axle?

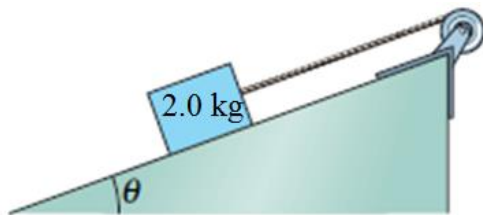

- A) $0.054 \text{ kg}\cdot\text{m}^2$
 B) $2.7 \text{ kg}\cdot\text{m}^2$
 C) $0.22 \text{ kg}\cdot\text{m}^2$
 D) $0.080 \text{ kg}\cdot\text{m}^2$
 E) $0.040 \text{ kg}\cdot\text{m}^2$

Q8.

Figure 5 shows a rectangular shaped object and four choices of rotation axes, all perpendicular to the face of the object. Rank the choices according to the rotational inertia of the object about the axis, greatest first.

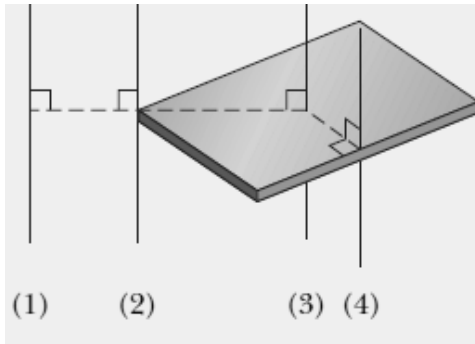

- A) 1, 2, 4, 3
 B) 1 and 2 tie, 4, 3
 C) 3, 4, 2, 1
 D) 3 and 4 tie, 1, 2
 E) all tie

Q9.

A particle is to move in an xy plane, clockwise around the origin as seen from the positive side of the z axis. In unit-vector notation, what torque acts on the particle if the magnitude of its angular momentum about the origin is $4.0 \text{ kg}\cdot\text{m}^2/\text{s}$ and $4.0t \text{ kg}\cdot\text{m}^2/\text{s}$, respectively? (the symbol t represents time)

- A) $0.0 \text{ N}\cdot\text{m}, -4.0 \text{ N}\cdot\text{m}\hat{k}$
 B) $0.0 \text{ N}\cdot\text{m}, 4.0 \text{ N}\cdot\text{m}\hat{k}$
 C) $4.0 \text{ N}\cdot\text{m}\hat{k}, 4.0 \text{ N}\cdot\text{m}\hat{k}$
 D) $0.0 \text{ N}\cdot\text{m}, -8.0 \text{ N}\cdot\text{m}\hat{k}$
 E) $4.0 \text{ N}\cdot\text{m}\hat{k}, 0.0 \text{ N}\cdot\text{m}$

Q10.

In **Figure 6**, a solid ball rolls smoothly from rest (starting at height $H = 3.0 \text{ m}$) until it leaves the horizontal section at the end of the track, at height $h = 1.0 \text{ m}$. What is the linear speed of the ball at the end of the track?

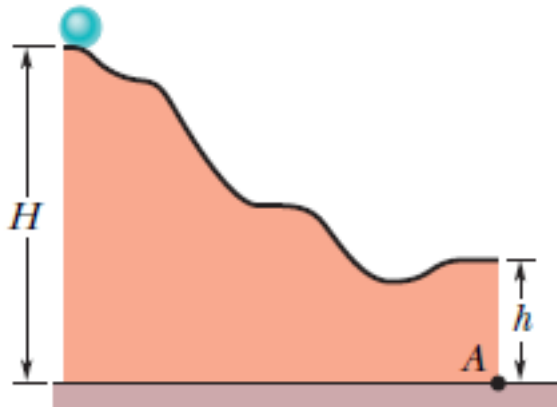

- A) 5.3 m/s
- B) 9.2 m/s
- C) 6.3 m/s
- D) 7.7 m/s
- E) 4.4 m/s

Q11.

In **Figure 7**, a 1.0 g bullet is fired into a 0.50 kg block attached to the end of a 0.60 m non uniform rod of mass 0.50 kg. The block–rod–bullet system then rotates in the plane of the figure, about a fixed axis (perpendicular to the page) at point **A**. The rotational inertia of the rod alone about that axis at **A** is $0.080 \text{ kg}\cdot\text{m}^2$. Treat the block as a particle. If the angular speed of the system about **A** just after impact is 5.5 rad/s , what is the bullet's speed just before impact?

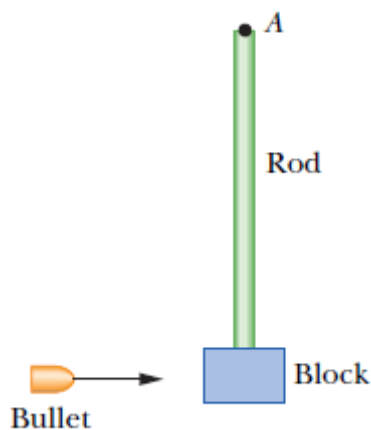

- A) $2.4 \times 10^3 \text{ m/s}$
- B) $7.3 \times 10^2 \text{ m/s}$
- C) $9.3 \times 10^2 \text{ m/s}$
- D) $4.9 \times 10^2 \text{ m/s}$
- E) $1.7 \times 10^3 \text{ m/s}$

Q12.

Three solid cylinders (1), (2) and (3) are of the same length (L) and made from the same material. The radii of the cylinders are 1.0 cm, 1.5 cm and 2.0 cm, respectively. Suppose all cylinders roll without slipping from rest down a ramp, as shown in **Figure 8**. Rank the cylinders according to their linear speed of the center of mass (v_{com}) as they reach the bottom of the ramp, greatest first.

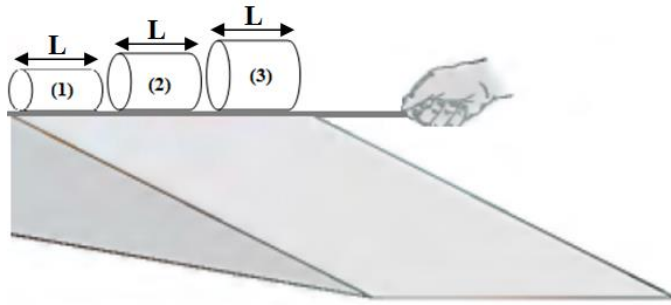

- A) All tie
 B) 1 and 2 tie, 3
 C) 3, 2, 1
 D) 2, 3, 1
 E) 1, 2, 3

Q13.

A uniform beam with a weight of 60.0 N and a length of 3.20 m is hinged at its lower end, and a horizontal force \vec{F} of magnitude 50.0 N acts at its upper end, as shown in **Figure 9**. The beam is held vertical by a cable that makes an angle $\theta = 25.0^\circ$ with the ground and is attached to the beam at height $h = 2.00$ m. What is the tension in the cable?

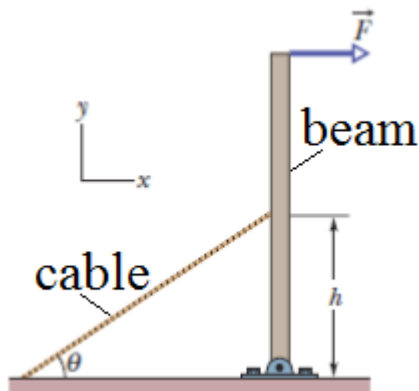

- A) 88.3 N
 B) 27.4 N
 C) 44.1 N
 D) 50.0 N
 E) 61.3 N

Q14.

A rod that is 4.0 m long and 0.50 cm^2 in cross-sectional area is attached to a ceiling from one end. It stretches 0.20 cm by hanging a block to the other end. If Young's modulus for this rod is $2.0 \times 10^{11} \text{ N/m}^2$, what is the weight of the hanging block? (Neglect the weight of the rod)

- A) $5.0 \times 10^3 \text{ N}$
 B) $5.1 \times 10^2 \text{ N}$
 C) $8.0 \times 10^3 \text{ N}$
 D) $2.0 \times 10^3 \text{ N}$
 E) $2.1 \times 10^2 \text{ N}$

Q15.

A uniform shelf of weight 50.0 N and length 60.0-cm is supported horizontally by two vertical wires attached to the sloping ceiling (see **Figure 10**). The lengths of wires **A** and **B** are 25.0 cm and 75.0 cm, respectively. A 25.0-N object is placed on the shelf midway between the points where the wires are attached to it. What are the tensions T_A and T_B in wires **A** and **B**, respectively?

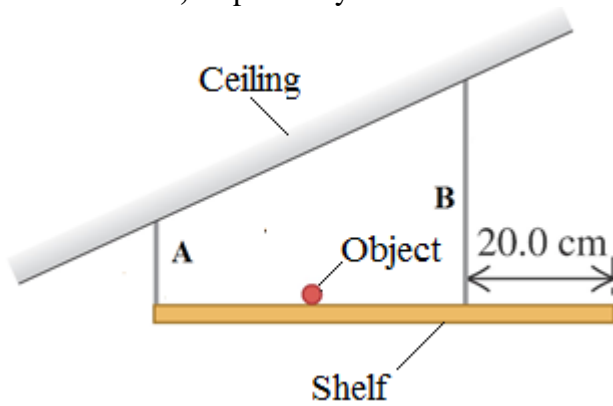

- A) $T_A = 25.0 \text{ N}$, $T_B = 50.0 \text{ N}$
- B) $T_A = 75.0 \text{ N}$, $T_B = 75.0 \text{ N}$
- C) $T_A = 25.0 \text{ N}$, $T_B = 75.0 \text{ N}$
- D) $T_A = 27.0 \text{ N}$, $T_B = 25.0 \text{ N}$
- E) $T_A = 50.0 \text{ N}$, $T_B = 50.0 \text{ N}$