

# Gain Control of Semiconductor Optical Amplifier Using a Bandpass Filter in a Feedback Loop

Khurram Karim Qureshi, H. Y. Tam, *Senior Member, IEEE*, C. Lu, *Member, IEEE*, and P. K. A. Wai, *Senior Member, IEEE*

**Abstract**—The authors present a simple configuration of a gain-clamped semiconductor optical amplifier (GC-SOA) based on automatic intensity control of a feedback light generated by amplified spontaneous emission, using a narrow bandwidth thin-film-tunable filter. Experimental results show that the proposed amplifier has good gain clamping characteristics and the feedback light dramatically reduces steady and transient gain variations. The feedback light operates satisfactorily with the channel's add-drop frequency up to 20.9 kHz. We also examined the performance of the GC-SOA by employing the feedback light at different wavelengths.

**Index Terms**—Optical gain control, relaxation oscillations, semiconductor optical amplifier (SOA).

## I. INTRODUCTION

SEMICONDUCTOR optical amplifiers (SOAs) have potential applications in optical communication systems as in-line amplifiers [1] and high-speed optical switches [2]. An SOA is small in size in comparison to fiber amplifiers. It also provides broad wavelength operation range, better integration, and low cost. However, in wavelength-division-multiplexing (WDM) systems, the gain saturation of conventional SOA leads to interchannel crosstalk and signal distortion. To overcome these pitfalls, gain-clamped (GC)-SOAs have been proposed and demonstrated [3]–[5]. The fact that they provide gain, independent of differential input power, has made them very popular for a wide range of applications. In the GC-SOA, the carrier density and optical gain are stabilized by a lasing oscillation that shares the same pool of carriers with the amplified optical signals. Distributed feedback grating [3] or distributed Bragg reflector [4] is monolithically integrated into the SOA for inducing the lasing oscillation. Here, the gain of the GC-SOA is predetermined by the device design and the internal laser wavelength is fixed. Manning and Davies [5] theoretically predicted that external light injection into SOA could increase the stimulated recombination rates and reduce their gain recovery times. Yoshino and Inoue [6] experimentally demonstrated that external light injection into an SOA could increase its saturation output power and that it could shorten

its gain response time. In [7] and [8], light injection at or near transparency wavelength of the SOA has been used to achieve fast response without reducing the gain of the SOA. The second approach is more flexible as the gain of the GC-SOA is not fixed by the design and the wavelength of the external laser can be changed. However, these schemes incorporate a separate semiconductor pump laser diode, which ultimately increase the cost of these amplifiers.

In this letter, we propose and demonstrate a method of controlling the output level of an SOA using control light generated by amplified spontaneous emission of the SOA. The control laser is generated by employing a narrow bandwidth filter in the feedback loop. With the optimized conditions for control light, the upper limit for allowable signal input power to obtain a constant gain is increased by 20 dB. The results also demonstrate an improvement in the saturation output power by 4.5 dB. The GC-SOA can also simplify the system design for WDM networks with dynamic add-drops. The power excursions experienced by the surviving channels are kept to a minimum by utilizing the proposed scheme.

## II. EXPERIMENTAL SETUP

The SOA used in this configuration is designed for operation in the *C*-band. The 3-dB gain bandwidth of the SOA is about 43 nm with the gain peak at 1550 nm. The SOA exhibits a small signal gain of around 19 dB with a polarization sensitivity of less than 1 dB. The single-oscillating control laser is formed by a pair of optical circulators, an SOA, a fiber Fabry-Pérot tunable filter (FFP-TF), and a variable optical attenuator (VOA). The operable temperature range of the FFP-TF is from  $-20\text{ }^{\circ}\text{C}$  to  $+80\text{ }^{\circ}\text{C}$ . The free-spectral range (FSR) of the filter is around 102 nm with a 3-dB bandwidth of 0.03 nm, and hence the finesse of the fiber FFP-TF is around 3400. The insertion loss of its passband is around 2.2 dB. The tuning voltage/FSR is around (0–16) V. The total round-trip loss is controlled by tuning the VOA placed in the cavity. The direction of the control light is opposite to the input signal and is established by the two circulators placed inside the cavity. The circulators also provide rejection of out-of-band reflection from the two ends of the FFP-TF to the SOA. Measurements of the output signal will not reveal the counterpropagating feedback control light. The wavelength of the feedback control laser could be changed by tuning the center wavelength of the FFP-TF which acts as a wavelength-selective element in this configuration. We analyzed this scheme for two cases, with the feedback control light wavelength at 1) 1537 nm, which lies within the gain bandwidth of the SOA and 2) 1597 nm, which lies outside the gain bandwidth of the SOA.

Manuscript received February 16, 2007; revised June 13, 2007.

K. K. Qureshi, C. Lu, and P. K. A. Wai are with the Photonics Research Center, The Hong Kong Polytechnic University, Hong Kong, China, and also with the Department of Electronic and Information Engineering, The Hong Kong Polytechnic University, Hong Kong, China (e-mail: kqureshi94@gmail.com).

H. Y. Tam is with the Photonics Research Center, The Hong Kong Polytechnic University, Hong Kong, China, and also with the Department of Electrical Engineering, The Hong Kong Polytechnic University, Hong Kong, China.

Color versions of one or more of the figures in this letter are available online at <http://ieeexplore.ieee.org>.

Digital Object Identifier 10.1109/LPT.2007.903501

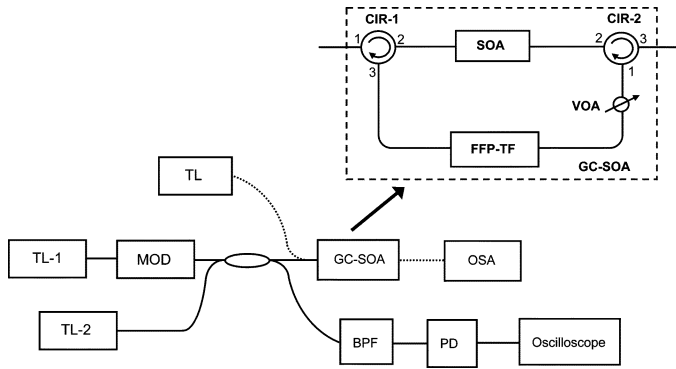
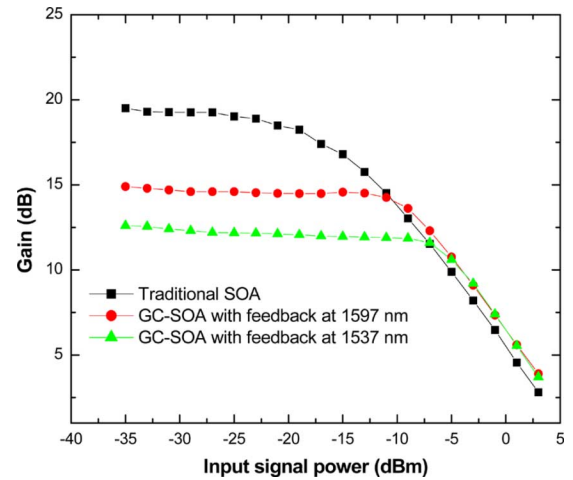

Fig. 1. Experimental setup to determine the steady-state (dotted lines) and transient (solid lines) properties of GC-SOA. Inset shows the schematic diagram of the GC-SOA. CIR: Circulator. MOD: Modulator. TL: Tunable laser. BPF: Bandpass filter. PD: Photodetector. OSA: Optical spectrum analyzer.

### III. EXPERIMENTAL RESULTS AND DISCUSSION

#### A. Steady-State Properties of GC-SOA

Fig. 1(dotted lines) shows the experimental setup used to measure the steady-state properties of the GC-SOA. The inset shows the schematic diagram of the GC-SOA. Fig. 2 compares the gain of the traditional SOA with that of a GC-SOA. The measurements are undertaken for signal wavelength at 1550 nm with its input power varying from  $-35$  to  $+3$  dBm. The small signal gain of the SOA without a feedback control laser is around 19 dB, shown as solid squares in Fig. 2(a). Initially, the VOA is not included in the cavity, which leads to minimal feedback loss. In the operation of GC-SOA, the small signal linear gain is about 15 dB, shown as solid circles in Fig. 2(a), when the feedback oscillating laser is generated at 1597 nm, which lies outside the gain bandwidth of SOA. The power independence of the gain only exists up to a certain value of the input signal power called the saturation power. Beyond the saturation power, crosstalk and distortion increase severely and, hence, this power determines the dynamic range of the GC-SOA. The optical power of the input signal could be up to  $-12$  dBm before clamping vanishes. The feedback control light is sufficient to keep the gain fixed because it will lock the population inversion level as long as the laser is above the lasing threshold. From Fig. 2(a), it is seen that the small signal gain varies less than 1 dB with the input power increase up to  $-12$  dBm. The small signal gain is about 12.5 dB, shown as solid triangles in Fig. 2(a), when the feedback oscillating laser is operated at 1537 nm, which lies within the gain bandwidth of the SOA. This is attributed to the fact that feedback control light at 1537 nm consumes more carriers that should otherwise contribute to the signal gain; consequently, the input signal gain is reduced more, compared with the case of feedback control laser at 1597 nm. The 3-dB saturation output power of the traditional SOA is around  $+3$  dBm. However, it increases to  $+5.5$  and  $+7.5$  dBm when the feedback light is applied at 1597 and 1537 nm, respectively. It is observed that, as the feedback light is utilized, the input signal gain gets reduced whereas the linear gain range becomes broadened. The benefit of this scheme is that by decreasing the signal gain while increasing the saturation output power raises the upper limit for the allowable signal input level. Next the VOA in the feedback is set at 5 dB. Since



(a)

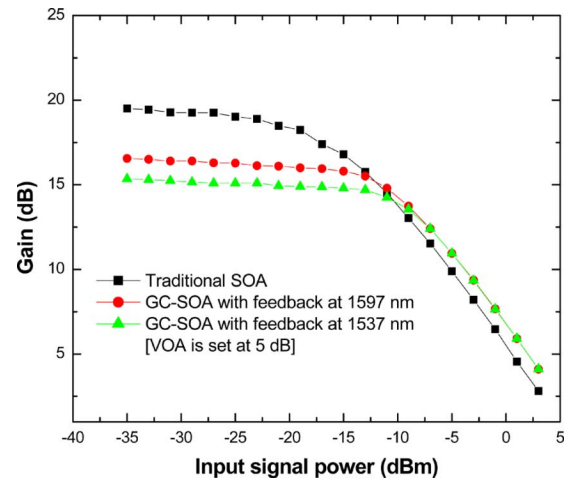

(b)

Fig. 2. Optical gain characteristics for various input powers of input signal. (a) VOA is not included. (b) VOA is set at 5 dB.

the feedback intensity is reduced in this case, the gain experienced by the input signal will increase. From Fig. 2(b), the small signal gain increases to about 16 dB when the feedback laser is at 1597 nm and it is about 15 dB when the feedback laser is set at 1537 nm. This feature provides a useful means to fine-tune the linear gain regime of the amplifier. Fig. 3 shows the relationship between the clamped gain and the VOA loss for different wavelengths of feedback control lasers. Initially, the clamped gain is higher when it lases at 1597 nm. However, when the VOA is set at 15 dB, the effect of feedback subsides due to substantial feedback loss in the cavity.

#### B. Transient Properties of GC-SOA

Here we delineate the transient properties of the proposed GC-SOA. Two tunable lasers are employed to simulate the power of eight wavelength channels [9]. The tunable laser (TL-1) is externally modulated (ON-OFF) at 20.9 kHz to simulate the adding and dropping of seven WDM channels. Another tunable laser (TL-2) acts as a surviving channel. The wavelengths of TL-1 and TL-2 are 1550 and 1554 nm, respectively. The two light sources are combined using a 3-dB coupler and

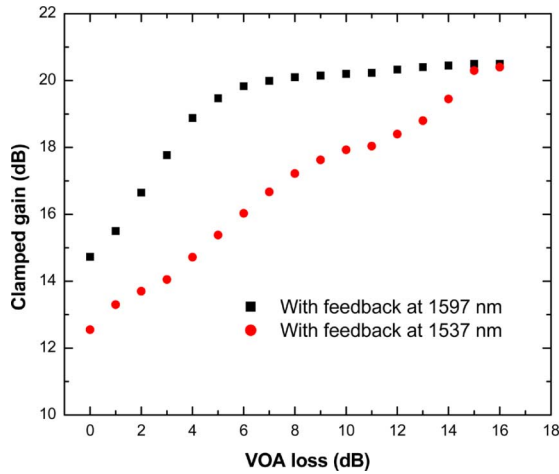

Fig. 3. Relationship between the clamped gain and VOA loss.

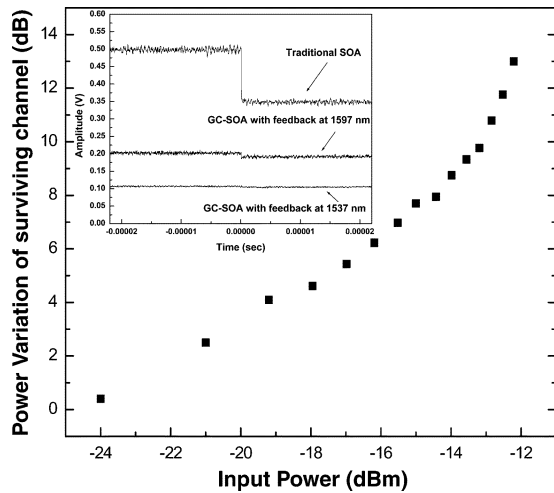

Fig. 4. Relationship between the power variation and input power range. The inset shows the output transients of the surviving channel at 1554 nm in the presence of 1550-nm channel add-drop modulation.

then launched into the GC-SOA. The two lasers are set in a way that when both of them are ON, the total input power to the GC-SOA is  $-15$  dBm, as would result from eight wavelength channels with an input power of  $-24$  dBm each. The input power from TL-1 is around  $-15.58$  dBm to simulate seven wavelength channels. The power of the surviving channel (TL-2) is fixed at  $-24$  dBm. The gain of the surviving channel is maintained at 15 dB. The optical power of this channel is detected and the transient response is measured. Fig. 4 shows the relationship between the power variations of the surviving channel for various input powers. With an increase in the input power; the power variation of the surviving channel also increases. The power variation becomes significant beyond an input power of about  $-13$  dBm. The inset of Fig. 4 shows the output transients experienced by the surviving channel upon the add-drop in three cases: 1) traditional SOA, 2) GC-SOA with optical feedback at 1597 nm, and 3) GC-SOA with optical feedback at 1537 nm. The maximum transient ratio is defined as  $K_m = (P_{max} - P_{min})/P_a$ , where  $P_{max}$ ,  $P_{min}$ , and  $P_a$

are maximum, minimum, and average output power of the surviving channel, respectively. The maximum steady-state transient ratio of the surviving channel is  $\sim 0.353$  for the case when there is no feedback gain-clamping mechanism. In contrast, the steady-state transient ratios are  $\sim 0.1$  and  $\sim 0.048$ , when the applied feedbacks are at 1597 and 1537 nm, respectively. The negligible gain transients are expected since the gain clamping is very efficient and fast for GC-SOA. In the absence of feedback control light, the surviving channel experiences a very strong cross-gain modulation effect which reduces upon the application of feedback control laser. The feedback control laser allows energy storage and reduces the longitudinal spatial hole burning in the GC-SOA [10]. Clearly, the feedback light at 1537 nm that lies within the gain bandwidth of the SOA provides the tightest transient control. A linear optical amplifier with a monolithically integrated vertical-cavity surface-emitting laser lasing at 1550 nm exhibits similar performance [11].

#### IV. CONCLUSION

We have proposed a simple GC-SOA scheme employing a bandpass filter in the feedback loop. The steady-state transient ratio of the surviving channel significantly reduces from 0.353 to 0.048 upon channel add-drop at 20.9 kHz. The control laser operates opposite to the signal direction and hence no optical filter is needed at the output to filter the feedback light.

#### REFERENCES

- [1] S. Ryu, S. Yamamoto, H. Taga, N. Edagawa, Y. Yoshida, and H. Wakabayashi, "Long-haul coherent optical fiber communication systems using optical amplifiers," *J. Lightw. Technol.*, vol. 9, no. 2, pp. 251–260, Feb. 1991.
- [2] Y. Maeno, Y. Suemura, A. Tajima, and N. Henmi, "A 2.56 Tb/s multiwavelength and scalable switch-fabric for fast packet-switching networks," *IEEE Photon. Technol. Lett.*, vol. 10, no. 8, pp. 1180–1182, Aug. 1998.
- [3] J. Park, X. Li, and W. P. Huang, "Gain clamping in semiconductor optical amplifiers with second-order index-coupled DFB grating," *IEEE J. Quantum Electron.*, vol. 41, no. 3, pp. 366–375, Mar. 2005.
- [4] J. Park, X. Li, and W. P. Huang, "Performance simulation and design optimization of gain-clamped semiconductor optical amplifiers based on distributed Bragg reflectors," *IEEE J. Quantum Electron.*, vol. 39, no. 11, pp. 1415–1423, Nov. 2003.
- [5] R. J. Manning and D. A. O. Davies, "Three-wavelength device for all optical signal processing," *Opt. Lett.*, vol. 19, pp. 889–891, 1994.
- [6] M. Yoshino and K. Inoue, "Improvement of saturation output power in a semiconductor laser amplifier through pumping light injection," *IEEE Photon. Technol. Lett.*, vol. 8, no. 1, pp. 58–59, Jan. 1996.
- [7] K. Inoue and M. Yoshino, "Gain dynamics of a saturated semiconductor laser amplifier with 1.47  $\mu\text{m}$  LD pumping," *IEEE Photon. Technol. Lett.*, vol. 8, no. 4, pp. 506–508, Apr. 1996.
- [8] K. P. Ho, S. K. Liaw, and C. Lin, "Reduction of semiconductor laser amplifier induced distortion and cross talk for WDM systems using light injection," *Electron. Lett.*, vol. 32, pp. 2210–2211, 1996.
- [9] C.-L. Zhao, B.-O. Guan, H. Y. Tam, W. H. Chung, X. Y. Dong, P. K. A. Wai, and X. Dong, "Performance of optical automatic gain control EDFA with dual oscillating control lasers," *Opt. Commun.*, vol. 224, pp. 281–287, 2003.
- [10] M.-S. Nomura, F. Salleras, M. A. Dupertuis, L. Kappei, D. Marti, B. Deveaud, J.-Y. Emery, A. Crottini, B. Dagens, T. Shimura, and K. Kuroda, "Density clamping and longitudinal spatial hole burning in a gain-clamped semiconductor optical amplifier," *Appl. Phys. Lett.*, vol. 81, pp. 2692–2694, 2002.
- [11] D. Francis, S. P. DiJaili, and J. D. Walker, "A single-chip linear optical amplifier," presented at the Optical Fiber Communication Conf. Exhibit (OFC 2001), Anaheim, CA, 2001, PDP.