

MicrostepPLD Driver Manual

Version 3/11/2004

Embedded Acquisition Systems
2517 Cobden Street
Sterling Heights, MI
48310
<http://www.embeddedtronics.com>
email sales@embeddedtronics.com
copyright 2003-2004

EAS MicrostepPLD is our 2 axis microstepping chopper driver board for stepper motors. It is based on the National Semiconductor LMD18245 3amp 55volt full bridge motor driver.

Specifications:

Xilinx CPLD based.

2 axis driver on one single board.

Supports half/full steps plus 4,5,6,8,10, or 16 microstep modes. Only one stepper mode can be programmed into the CPLD at one time, please state which version required when ordering.

Drives 4,6 or 8 wire bipolar/ unipolar stepper motors up to 3amps at 55volts per phase.

Adjustable chopper current drive.

Standard TTL step, direction and enable inputs.

Power connections.

The EAS MicrostepPLD driver board has a 55Volt maximum input voltage for powering stepper motors. Power leads must be connected to correct terminal screw. Do not reverse the power input or exceed 55volts, the LMD18245 drivers can be damaged by this.

Connect your stepper power supply to the MOT PWR screw terminal located on the right side of the board. Positive supply input connects to screw terminal labeled +.

If stepper motor power supply is far away from driver board, connect a 470uf 65volt capacitor directly to MOT PWR screw terminals.

The driver board also requires a separate supply to power the low voltage section of the driver board. Connect an 8-12volt supply to the screw terminals labeled PWR and GND. The PWR terminal is +positive supply input. This terminal is located near the front right side of the board. You can use the 12volt computer disk drive cable connector to supply power to the board. This is the recommended way to hook up power to the onboard 5 volt regulator.

Always turn on the low voltage power supply/Computer before turning on the higher voltage stepper motor power supply.

Step/Direction connections.

Connect your step and direction signals from your parallel port to the ST1/DR1 and ST2/DR2 screw terminals. ST1/DR1 terminals are the inputs to the LMD18245 A and B stepper motor drivers. ST2/DR2 terminals are the inputs to the LMD18245 C and D stepper motor drivers. You will also need to connect the parallel port ground pin 25 to the terminal labeled GND.

Enable Connection

EN1 and EN2 terminals can be used to disable power to the stepper motors. A low signal will disable and will stop the stepper motors.

EN1 terminal is used to disable the LMD18245 A and B stepper motor drivers.
EN2 terminal is used to disable the LMD18245 C and D stepper motor drivers.

Normal operation, the enable terminals is high or set to +5 volts. If this feature isn't needed, you can connect EN1 and EN2 to the terminal labeled VCC with a short piece of wire. VCC is +5 output from the onboard voltage regulator.

Current Resistor Setting

The maximum driver current output is set by resistor R6/R14 and R7/R15. The LMD18245 can drive stepper motors up to 3amps per phase. Higher current rated stepper motors can be used but maximum listed torque will not be achieved. You must attach the LMD18245 driver chips to a large heatsink for them to operate properly. There is a small hole on each tab for a screw to help mount them to a heatsink securely. Use white silicon heatsink compound for better heat transfer. The tabs on the LMD18245 is the same as ground, do not let bare wires touch the heatsink or driver chips. A fan blowing directly on the heatsink is also highly recommended.

The current sense resistor can be calculated by the following formula:

$$20,000 / A = R$$

R value is in ohms

A value is in amps

Current resistor typical values:

R=20K 1amp

R=10K 2amp

R=8K 2.5amp

R=6.6K 3amp

Use 1/4 watt resistors and do not use lower than a 6.6K value.

Each pair of LMD18245 driver chips must be set to the same output current limit. Use the same resistor value for R6 and R14 for drivers A and B. Also the same resistor value for R7 and R15 for drivers C and D. Do not set the drivers to output more than 3 amps, they will fail. If you have two stepper motors with different current ratings, drivers A and B can be set to different current output rating than drivers C and D.

Optional variable current output can be had by removing resistor R6,R14,R7,R15 and installing the 25K pots R8,R16,R9,R17 and 6.6K resistors R4,R12,R5,R13.

The set resistance value must not be lower than 6.6K. We recommend users to install resistors R6,R14,R7,R15 instead of the variable pots.

J3 Ground solder point.

You must solder together jumper J3 on the driver board or the board will not function. This connects the analog ground to the digital ground. It is located in near the right side of the board, silkscreened labeled SHORT.

Future upgrade.

When we designed this board, we put in some additional parts on the schematic for future expansion capability. The parts listed on the schematic lower left hand can be ignored.

Do not install:

U7 oscillator

U8 reset chip

Headers JP8, JP10 and JP2

Resistors R19,20,21,22

Stepper motor driver connections.

4 wire stepper motor connection.

For stepper motor 1

Wire 1 connects to A1 terminal

Wire 2 connects to A2 terminal

Wire 3 connects to B1 terminal

Wire 4 connects to B2 terminal

For stepper motor 2

Wire 1 connects to C1 terminal

Wire 2 connects to C2 terminal

Wire 3 connects to D1 terminal

Wire 4 connects to D2 terminal

Adjust drive current setting to no more than motor rated current specification.

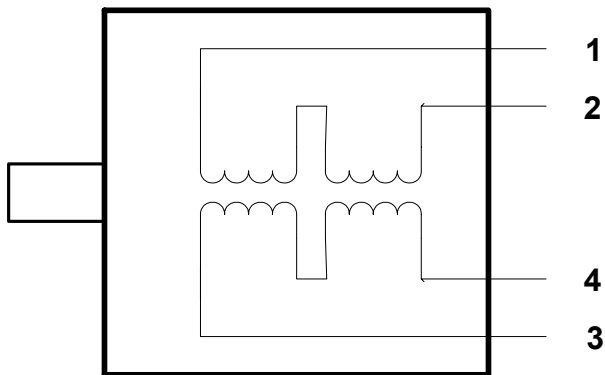

6 wire stepper motor, half winding connection.

For stepper motor 1

Wire 1 connects to A1 terminal

Wire 2 connects to A2 terminal

Wire 3 not connected

Wire 4 connects to B1 terminal

Wire 5 connects to B2 terminal

Wire 6 not connected

For stepper motor 2

Wire 1 connects to C1 terminal

Wire 2 connects to C2 terminal

Wire 3 not connected

Wire 4 connects to D1 terminal

Wire 5 connects to D2 terminal

Wire 6 not connected

Adjust drive current setting to no more than motor rated current specification.

This is the preferable way to hook up a 6 wire stepper motor to the driver. 6 wire half winding mode has lower inductance than 6 wire full winding. The stepper motor will be able to spin faster.

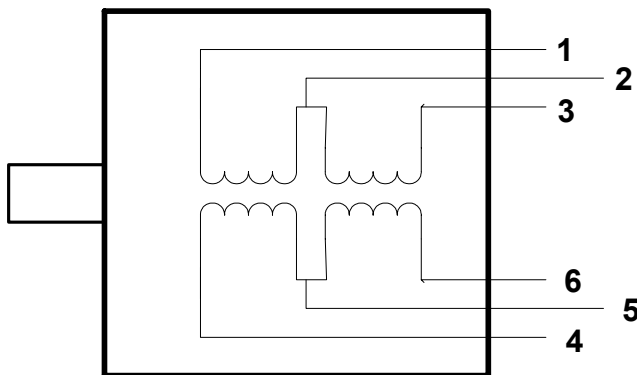

6 wire stepper motor, full winding connection.

For stepper motor 1

Wire 1 connects to A1 terminal

Wire 2 not connected

Wire 3 connects to A2 terminal

Wire 4 connects to B1 terminal

Wire 5 not connected

Wire 6 connects to B2 terminal

For stepper motor 2

Wire 1 connects to C1 terminal

Wire 2 not connected

Wire 3 connects to C2 terminal

Wire 4 connects to D1 terminal

Wire 5 not connected

Wire 6 connects to D2 terminal

Adjust drive current setting to half of the motor rated current specification.

6 wire full winding mode can be used for stepper motors that have high nameplate current specification. It will maximize the available torque at the expense of motor RPM due to increased winding inductance.

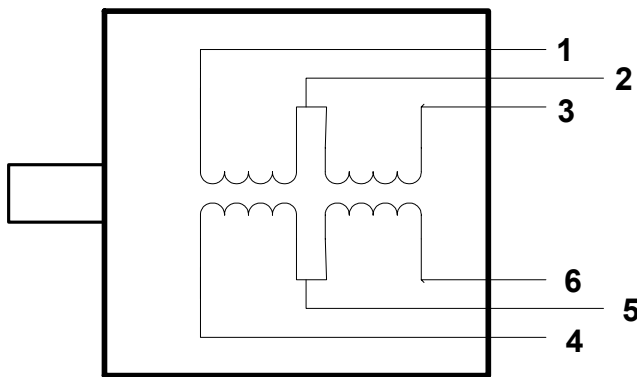

MicrostepPLD Driver Dual Axis Wiring Diagram

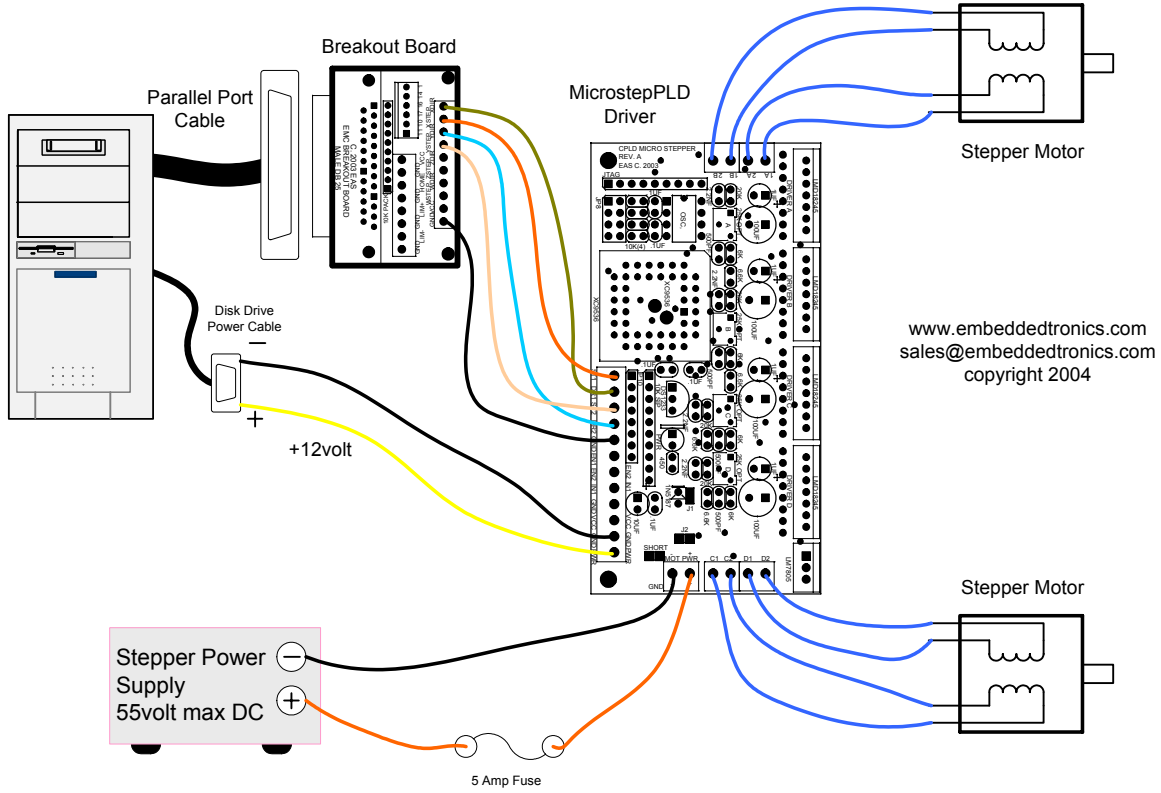

STANDARD LEGAL STUFF

Although all of the circuits and projects provided have been thoroughly tested by Embedded Acquisition Systems (EAS). We cannot take responsibility for the circuits, nor will we take any responsibility for anything happening as a result of using any of our designs.

PERFORMANCE INFORMATION: Performance tests and ratings are measured using specific computer systems and/or components and reflect the approximate performance of EAS products as measured by those tests. Any difference in system hardware or software design or configuration may affect actual performance.

SINGLE COPY LICENSE: You may download copies of the information or software ("Materials") found on EAS sites on a single computer for your personal, non-commercial internal use only. This is a license, not a transfer of title, and is subject to the following restrictions: you may not: (a) modify the Materials or use them for any commercial purpose, or any public display, performance, sale or rental; (b) decompile, reverse engineer, or disassemble software Materials; (c) remove any copyright or other proprietary notices from the Materials; (d) transfer the Materials to another person. You agree to prevent any unauthorized copying of the Materials.

OWNERSHIP OF MATERIALS: Materials are copyrighted and are protected by worldwide copyright laws and treaty provisions. They may not be copied, reproduced, modified, published, uploaded, posted, transmitted, or distributed in any way, without EAS's prior written permission. Other rights may be granted to you by EAS in writing or incorporated elsewhere in the Materials.

TERMINATION OF THIS LICENSE: EAS may terminate this license at any time if you are in breach of the terms of this Agreement. Upon termination, you will immediately destroy the Materials.

DISCLAIMER: The materials are provided "as is" without any express or implied warranty of any kind including warranties of merchantability, noninfringement of intellectual property, or fitness for any particular purpose. In no event shall EAS, or its suppliers be liable for any damages whatsoever (including, without limitation, damages for loss of profits, business interruption, loss of information) arising out of the use of or inability to use the materials, even if EAS has been advised of the possibility of such damages.

BECAUSE SOME JURISDICTIONS PROHIBIT THE EXCLUSION OR LIMITATION OF LIABILITY FOR CONSEQUENTIAL OR INCIDENTAL DAMAGES, THE ABOVE LIMITATION MAY NOT APPLY TO YOU.

EAS further does not warrant the accuracy or completeness of the information, text, graphics, links or other items contained within these materials. EAS may make changes to these materials, or to the products described therein, at any time without notice. EAS makes no commitment to update the Materials.