

High Performance Motor Drive Using Matrix Converter

A. DJAHBAR¹ B. MAZARI¹ N. MANSOUR²
a_djahbar@yahoo.fr mazari_dz@yahoo.fr nmansour@eng.uob.bh

¹ Laboratory of Development of Electric Drives
University of Sciences and Technology
Faculty of Electrical Engineering
Oran, Algeria

² University of Bahrain, Faculty of Engineering
Bahrain

Abstract— In this paper, a control strategy of scalar modulation with three intervals and vector control technique for matrix converter fed induction motor drive system is proposed. By applying this control strategy, we will be able to combine the advantages of matrix converter and the advantages of the vector control. Simulation results are shown to demonstrate the effectiveness of the proposed control scheme.

Keywords: Matrix converter, three-phase Induction Machine, Modulation of VENTURINI, Scalar Modulation, Vector control.

I. INTRODUCTION

Matrix converter (MC) is a modern energy conversion device that has been developed over the last two decades [1], [2]. Matrix converter fed motor drive is superior to pulse width modulation (PWM) inverter drives because it provides bidirectional power flow, sinusoidal input/output currents, and adjustable input power factor. Furthermore, matrix converter allows a compact design due to the lack of dc-link capacitors for energy storage. However, only a few of practical matrix converters have been applied to vector control system of induction motors (IM) for some well-know reasons: 1)Implementation of switch devices in matrix converter is difficult; 2) Modulation technique and commutation control are more complicated than conventional PWM inverter [2].

In order to realize high performance control of matrix converter fed induction motor drive system, three strategies of modulation of matrix converter are used [3],[4]:

The first is based on algorithm proposed by VENTURINI and ALESINA [3], the second is based on technique of space vector modulation (SVM), and the last is the scalar modulation [5], [6]. The synoptic diagram of matrix converter fed an induction machine is given to the figure1.

The basic matrix converter configuration with high frequency (HF) control was originally introduced in 1980 [4]. Since then, matrix converters have been subject of intensive research which mostly concentrated on two aspects:

Implementation of the matrix converter switches and the matrix converter control [5].

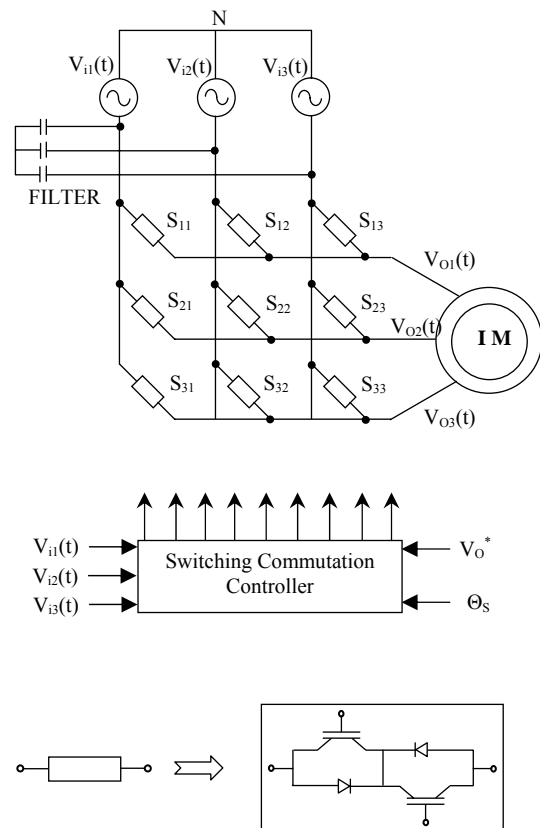

Figure 1. The topology of three-phase to three-phase matrix converter and the configuration of bi-directional switch.

II. FIELD ORIENTED CONTROL

The field oriented control, published for the first time by BLASCHKE in his pioneering work in 1972, consists in adjusting the flux by a component of the current and the torque by the other component. For this purpose, it is necessary to choose a d-q reference frame rotating synchronously with the

rotor flux space vector, in order to achieve decoupling control between the flux and the produced torque. This technique allows to obtain a dynamical model similar to the DC machine [1]. The regulation of the flux can be direct or indirect. In the direct control, the rotor flux is estimated or reconstructed (Fig. 2). The field orientation is obtained by imposing the condition ($\varphi_{dr}=\varphi_r$ and $\varphi_{qr}=0$). From this condition, the i_{ds} reference can be computed in order to impose the flux φ_r . Furthermore, the position θ_s of the rotating frame can be estimated by [1]:

$$\begin{cases} \frac{d\Phi_r}{dt} = \frac{R_r}{L_r} (L_m i_{ds} - \Phi_r) \\ \frac{d\Theta_s}{dt} = w_s = w_m + \frac{L_m i_{qs}}{T_r \Phi_{qr}} \end{cases} \quad (1)$$

With taking into account the field orientation of the machine, the stator equations on d-q axis become [1]:

$$\begin{cases} v_{ds} = R_s i_{ds} + \sigma L_s \frac{di_{ds}}{dt} + \frac{L_m}{L_r} \frac{d\Phi_r}{dt} - \sigma L_s w_s i_{qs} \\ v_{qs} = R_s i_{qs} + \sigma L_s \frac{di_{qs}}{dt} + w_s \frac{L_m}{L_r} \Phi_r + \sigma L_s w_s i_{ds} \end{cases} \quad (2)$$

Using the system given by Eq.2, we can remark the interaction of both inputs, which makes the control design more difficult. The first step of our work is to obtain a decoupled system in order to control the electromagnetic torque via stator quadrature current i_{qs} such as DC machine. A decoupled model can be obtained by using two intermediate variables:

$$\begin{cases} v_{ds}^* = v_{ds} + v_1 \\ v_{qs}^* = v_{qs} + v_2 \end{cases} \quad (3)$$

Or v_1 and v_2 are electromotive forces that introduce a coupling between the axes d and q.

The stator voltages (v_{ds} , v_{qs}) are reconstituted from (v_{ds}^* , v_{qs}^*). The speed regulation is reached by an IP regulator, flux and currents regulation are reached by PI regulators (Fig.2).

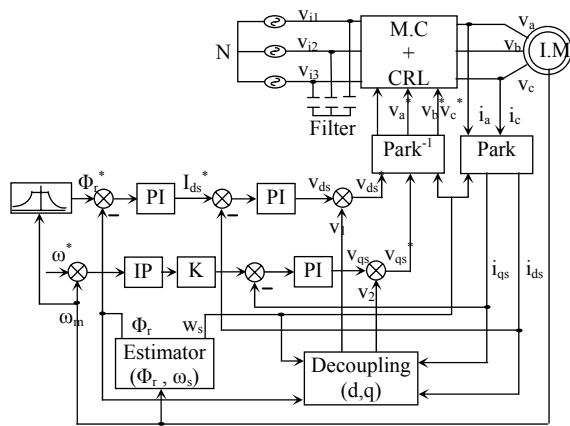

Figure 2. Direct field oriented control of an Induction Machine fed from a matrix converter.
($k=L_r/pL_m\Phi_r^*$)

III. MATRIX CONVERTER THEORY

a. Problem definition

The schematic diagram of a three-phase matrix converter is presented in Fig.1. Its inputs are the phase voltages v_{i1}, v_{i2}, v_{i3} , and its outputs are the voltages v_{o1}, v_{o2}, v_{o3} , (in Eq.5 this notation is used for the first harmonic of the output voltages). The matrix converter components ($s_{11}, s_{12}, \dots, s_{33}$) represent nine bi-directional switches witch are capable of blocking voltage in both directions and of switching without any delays. These are nine ideal switches.

The matrix converter connects the three given inputs, with constant amplitude V_i and frequency $f_i=\omega_i/2\pi$, through the nine switches to the output terminals in accordance with precalculated switching angles. The three-phase output voltages obtained have controllable amplitudes V_o and frequency $f_o=\omega_o/2\pi$.

The input three-phase voltages of the converter are given by:

$$\begin{bmatrix} v_{i1} \\ v_{i2} \\ v_{i3} \end{bmatrix} = V_{im} \begin{bmatrix} \cos(w_i t) \\ \cos(w_i t - 2\pi / 3) \\ \cos(w_i t - 4\pi / 3) \end{bmatrix} \quad (4)$$

The required first harmonic of the output phase voltages of the unloaded matrix converter is [3]:

$$\begin{bmatrix} v_{o1} \\ v_{o2} \\ v_{o3} \end{bmatrix} = V_{om} \begin{bmatrix} \cos(w_o t) \\ \cos(w_o t - 2\pi / 3) \\ \cos(w_o t - 4\pi / 3) \end{bmatrix} \quad (5)$$

The problem at hand may be defined as follows: with input voltages as Eq.4, the matrix converter switching angles equations will be formulated so that the first harmonic of the output voltages will be as Eq.5.

b. The switching angles formulation

The switching angles, of the nine bidirectional switches $s_{ij}(i=1,2,3$ and $j=1,2,3)$ witch will be calculated, must comply with the following rules [7]:

1. At any time 't', only one switch s_{ij} ($j=1,2,3$) will be in 'ON' state. This assures that no short circuit will occur at the input terminals.
2. At any time 't', at least two of the switches $s_{ij}(i=1,2,3)$ will be in 'ON' state. This condition guarantees a closed-loop path for the load current (usually this is an inductive current).
3. The switching frequency is f_s and its angular frequency ($\omega_s=2\pi f_s$) complies with $\omega_s \gg \omega_i$ and ω_o : in other words the switching frequency is much higher ($f_s \approx 20 \times \max(f_i, f_o)$) than the input and output frequencies.

During the k^{th} switching cycle T_s ($T_s=1/f_s$) (Fig.3), the first phase output voltage is given by:

$$v_{o1} = \begin{cases} v_{i1} & 0 \leq t - (k-1)T_s < m_{11}^k T_s \\ v_{i2} & m_{11}^k T_s \leq t - (k-1)T_s < (m_{11}^k + m_{12}^k) T_s \\ v_{i3} & (m_{11}^k + m_{12}^k) T_s \leq t - (k-1)T_s < T_s \end{cases} \quad (6)$$

Where 'm's are defined by :

$$m_{ij}^k = \frac{t_{ij}^k}{T_s} \quad (7)$$

Where t_{ij}^k : time interval when s_{ij} is in 'ON' state, during the k^{th} cycle, and k is being the switching cycle sequence number.

The 'm's have the physical meaning of duty cycle.

Also,

$$\sum_{j=1}^3 m_{ij}^k = m_{i1}^k + m_{i2}^k + m_{i3}^k = 1 \quad \text{and} \quad 0 < m_{ij}^k < 1 \quad (8)$$

Which means that during every cycle T_s all switches will turn on and off once.

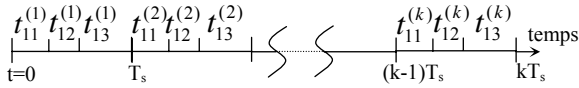

Figure 3. Segmentation of the axis time for the consecutive orders of intervals closing of the switches.

c. Algorithm of VENTURINI

The algorithm of VENTURINI [2], [3], allows a control of the S_{ij} switches so that the low frequency parts of the synthesized output voltages v_{oij} and the input currents i_{ij} are purely sinusoidal with the prescribed values of the output frequency, the input frequency, the displacement factor and the input amplitude. The average values of the output voltages during the k^{th} sequence are thus given by:

$$\begin{aligned} v_{o1}^{(k)} &= v_{i1}^{(k)} \frac{t_{11}^{(k)}}{T_s} + v_{i2}^{(k)} \frac{t_{12}^{(k)}}{T_s} + v_{i3}^{(k)} \frac{t_{13}^{(k)}}{T_s} \\ v_{o2}^{(k)} &= v_{i1}^{(k)} \frac{t_{21}^{(k)}}{T_s} + v_{i2}^{(k)} \frac{t_{22}^{(k)}}{T_s} + v_{i3}^{(k)} \frac{t_{23}^{(k)}}{T_s} \\ v_{o3}^{(k)} &= v_{i1}^{(k)} \frac{t_{31}^{(k)}}{T_s} + v_{i2}^{(k)} \frac{t_{32}^{(k)}}{T_s} + v_{i3}^{(k)} \frac{t_{33}^{(k)}}{T_s} \end{aligned} \quad (9)$$

If times of conduction are modulated in the shape of sinusoid with the pulsation w_m while T_s remains constant, such as $w_o = w_i + w_m$, these times are defined as follows:

1. For the 1st phase, we have:

$$\begin{aligned} t_{11} &= \frac{T_s}{3} (1 + 2q \cos(w_m t + \theta)) \\ t_{12} &= \frac{T_s}{3} (1 + 2q \cos(w_m t + \theta - \frac{2\pi}{3})) \\ t_{13} &= \frac{T_s}{3} (1 + 2q \cos(w_m t + \theta - \frac{4\pi}{3})) \end{aligned} \quad (10)$$

2. For the 2nd phase:

$$\begin{aligned} t_{21} &= \frac{T_s}{3} (1 + 2q \cos(w_m t + \theta - \frac{4\pi}{3})) \\ t_{22} &= \frac{T_s}{3} (1 + 2q \cos(w_m t + \theta)) \\ t_{23} &= \frac{T_s}{3} (1 + 2q \cos(w_m t + \theta - \frac{2\pi}{3})) \end{aligned} \quad (11)$$

3. For the 3rd phase:

$$\begin{aligned} t_{31} &= \frac{T_s}{3} (1 + 2q \cos(w_m t + \theta - \frac{2\pi}{3})) \\ t_{32} &= \frac{T_s}{3} (1 + 2q \cos(w_m t + \theta - \frac{4\pi}{3})) \\ t_{33} &= \frac{T_s}{3} (1 + 2q \cos(w_m t + \theta)) \end{aligned} \quad (12)$$

Where θ is initial phase angle.

The output voltage is given by [7]:

$$[V_o^{(k)}] = [M^{(k)}] [V_i^{(k)}] \quad (13)$$

$$[M^{(k)}] = \frac{1}{3} \begin{bmatrix} 1 + 2q \cos A & 1 + 2q \cos(A - \frac{2\pi}{3}) & 1 + 2q \cos(A - \frac{4\pi}{3}) \\ 1 + 2q \cos(A - \frac{4\pi}{3}) & 1 + 2q \cos A & 1 + 2q \cos(A - \frac{2\pi}{3}) \\ 1 + 2q \cos(A - \frac{2\pi}{3}) & 1 + 2q \cos(A - \frac{4\pi}{3}) & 1 + 2q \cos A \end{bmatrix}$$

$$\text{Where: } \begin{cases} A = w_m t + \theta \\ w_m = w_o - w_i \end{cases}$$

The running matrix converter with the VENTURINI algorithm generates at the output a three-phases sinusoidal voltage system having in that order pulsation w_m , a phase angle θ and amplitude $q \cdot V_{im}$ ($0 < q < 0.866$ with modulation of the neutral) [3].

d. Scalar method of ROY

This method uses the instantaneous ratios of the input phase voltages so as to determinate the modulation matrix coefficients m_{ij} . The average value of the output voltage for the 1st phase is given by [1] :

$$v_{o1} = \frac{1}{T_s} (t_k v_k + t_l v_l + t_m v_m) = v_{om} \cos(w_o t) \quad (14)$$

With: $t_k + t_l + t_m = T_s$

Where K, L and M are indexes, which can be assigned with the input voltage indexes j (j=1,2,3) according to following rules [1]:

1st rule: At any moment, the input phase voltage having the discriminate polarity from the two other input phases is assigned with L.

2nd rule: The two input phase voltages having the same polarity are assigned with M and K, smallest of both (in absolute value), being K. Times of conduction t_k and t_l are selected such as:

$$\frac{t_k}{t_l} = \frac{v_k}{v_l} = \rho \quad (15)$$

In addition: $0 \leq \rho \leq 1$

The converter chopping is only up to the scalar comparison between input phase voltages and the instantaneous desired output voltage value v_o . Times of conduction t_k , t_l and t_m during one period of switching are given as follows [1]:

$$\begin{cases} t_l = \frac{T_s (v_o - v_m)}{\rho v_k + v_l - (1 + \rho)v_m} \\ t_k = \rho t_l \\ t_m = T_s - (\rho + 1)t_l \end{cases} \quad (16)$$

IV. SIMULATION RESULTS

A. Performance of VENTURINI modulation strategy

With this strategy, we simulate the simple and compound voltages delivered by the matrix converter.

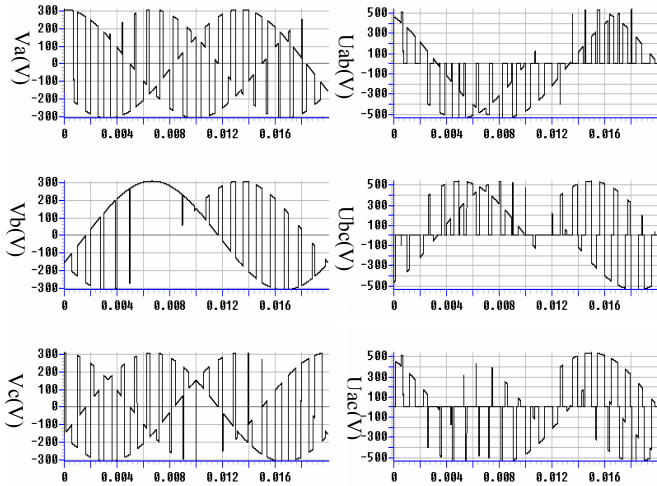

Figure 4. voltages waveforms v_a , v_b , v_c , u_{ab} , u_{bc} and u_{ac} , for: $f_s=1$ kHz, $f_i=50$ Hz, $f_o=25$ Hz, $q=0.57$

Simulation results of the starting process of an induction motor fed from a matrix converter for a frequency $f_s=2$ kHz are shown on the Fig.5.

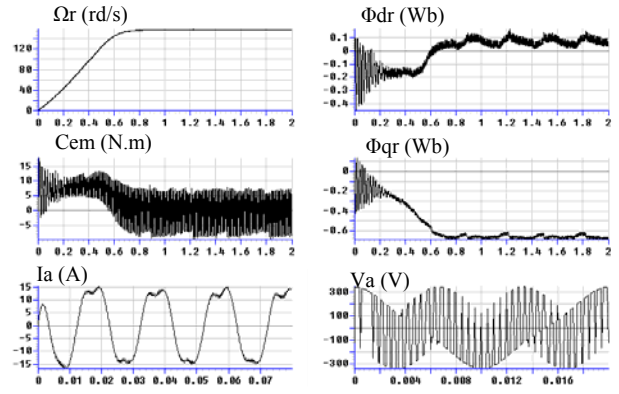

Figure 5. Response of rotor speed, developed torque, phase current, simple voltage and rotor flux for: $f_o=50$ Hz, $q=0.866$

B. Scalar modulation strategy performances

The average output voltage without and with modulation of the neutral are depicted on the Fig.6, one notices that the output voltages are limited to half for $q=0.57$. With an aim of improving q with 0.866, one add to the output voltage the 3rd harmonic of the input voltage with amplitude equal to $V_{im}/4$ and one subtracts the 3rd harmonic from the output voltage with amplitude equal to $V_{om}/6$ [7].

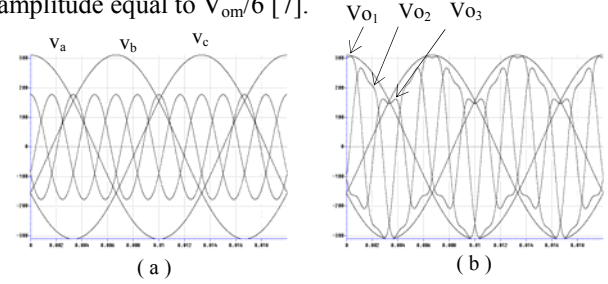

Figure 6. Input simple voltages and desired output waveforms for: $f_s=2$ KHz, $f_o=200$ Hz
(a) : $q=0.57$, (b) : $q=0.866$

The simple and compound voltages waveforms delivered by the MC are shown on the Fig.7.

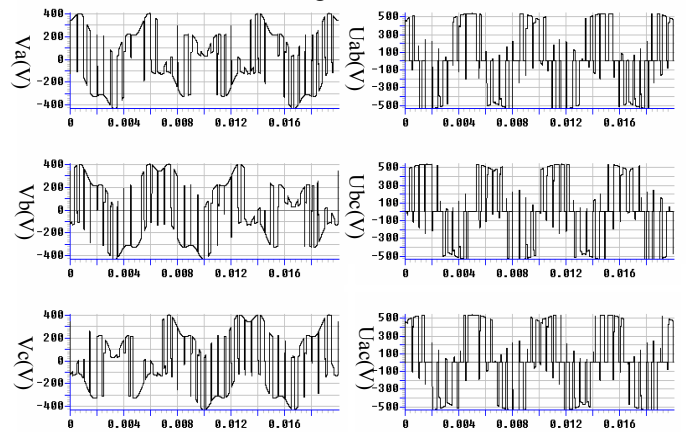

Figure 7. voltages waveforms, v_a , v_b , v_c , u_{ab} , u_{bc} and u_{ac} , for: $f_s=2$ kHz, $f_i=50$ Hz, $f_o=200$ Hz, $q=0.866$

The simulation of the direct vector control of the induction motor associated with a matrix converter, controlled by the scalar modulation strategy is given by the Fig.9. The Fig.8 shows the decoupling carried out between the flux and the electromagnetic torque, the Fig.9 represent step speed from 0 to 100 rd/s then application of a load torque of 10 Nm between 0.5s and 1.5s and finally an inversion of rotary motion at the moment 2 s from a speed of 100 rd/s to -100 rd/s.

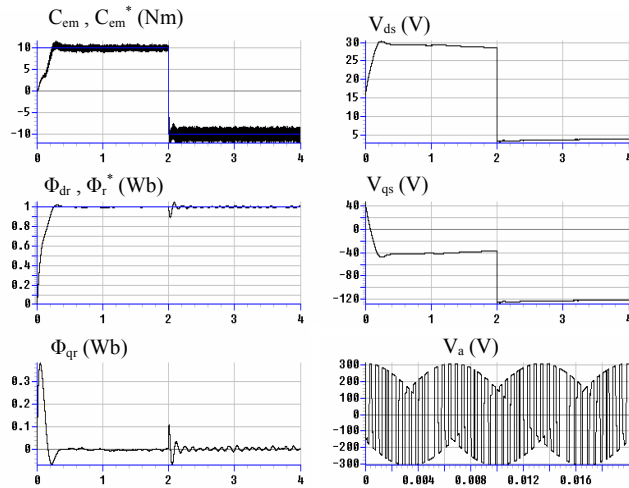

Figure 8. Decoupling flux - torque at $f_s=2$ kHz.

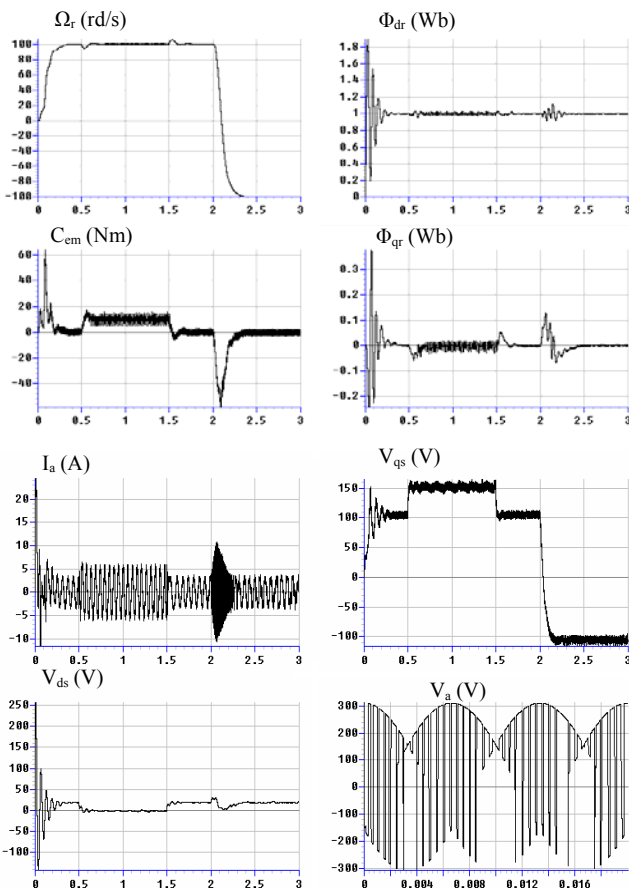

Figure 9. Direct vector control response ($f_s=2$ kHz).

V. CONCLUSION

Vector control of induction machine fed from a three phase matrix converter modeling and simulation have been described. The main topics discussed in the paper were:

- review of matrix converter;
- switching angles calculation;
- converter modeling and simulation;
- field oriented control modeling and simulation.

To our knowledge, this is the first time that a field oriented control of induction machine supplied from a matrix converter has been simulated, this being the main contribution of the paper. High performances of the direct vector control are achieved with the use of matrix converter.

According to the simulation results obtained, the control algorithm presented is advisable for the establishment in the industrial drives.

The next step of this research will be the realization of the motor drive.

VI. APPENDIX

The parameters of the induction machine used are:

$$N_n=1420 \text{ r/min}, f_n=50 \text{ Hz}, P_n=1.5 \text{ kW}$$

$$220/380 \text{ V}, 3.64/6.31 \text{ A}$$

$$R_s=4.850 \Omega, R_r=3.805 \Omega, L_s=L_r=0.274 \text{ H}, L_m=0.258 \text{ H}$$

$$J=0.031 \text{ kg.m}^2, k_f=0.001136 \text{ kg.m}^2/\text{s}.$$

VII. REFERENCES

- [1] C. KLUMPNER, I. BOLDEA "Artificial loading of induction machine using a matrix converter," IEE Power electronics, N° 475, pp. 40-45, 2000.
- [2] M. VENTURINI "A new sine wave in sine wave out conversion technique eliminates reactive elements," Proc. of power con.7, San-diego, pp.E3-1/E3-15, 1980.
- [3] M. VENTURINI "The Generalized transformer: a new bidirectional sinusoidal waveform, frequency converter with continuously adjustable input power factor," Proc. of PESC, pp.242-252, Rec.1980.
- [4] A. ALESINA, M. VENTURINI "Solid-state power conversion : a Fourier analysis approach to generalized transformer synthesis," IEEE Trans. on circuit and systems, vol.cas-28, N°4. pp 319-330, 1981.
- [5] A. ALESINA, M. VENTURINI "Intrinsic amplitude limits and optimum design of 9 switches direct PWM ac-ac converter," Proc. of PSEC con. pp.1284-1290, Rec.april 1988.
- [6] D.G. HOLMES, T.L. LIPO "Implementation of a controlled rectifier using ac-ac matrix converter theory," IEEE Trans. on power electronics, vol.7 N°1, pp.240-250, Jan.1992.
- [7] ALESINA, M. VENTURINI "Analysis and design of optimum amplitude nine switch direct ac-ac converters," IEEE Trans. On Power Electronics, vol.4, N°1, pp.101-112, Jan. 1989.