

Generation of Wideband FM Waves

Contents

Direct Method of Generating WB FM Signals	1
Features of the Direct Method.....	1
Armstrong Indirect Method for Wideband FM Generation	2
Example 1	2
System 1.....	3
System 2.....	3
System 3.....	4
Practical FM radio broadcasting	4

Direct Method of Generating WB FM Signals

This method is simple in the sense that it uses a single component: the voltage-controlled oscillator (VCO). As described in the section of **Carrier Acquisition for DSBSC systems**, VCOs are devices that produce a sinusoid with a frequency that is proportional to the input signal. So, if the input signal to a VCO is the message signal, the output of the VCO will be an FM modulated signal of the message signal since the frequency of this FM signal changes according to the input message signal.

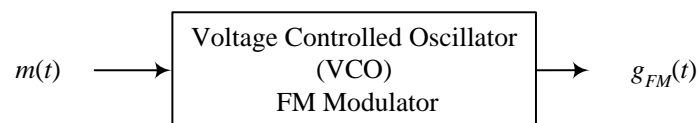

Features of the Direct Method

1. Poor frequency stability. (can be improved using feedback. The details are beyond the our scope) (-ve feature)
2. Less multiplication requirements as compared to the indirect method as will be seen (+ve feature).

Armstrong Indirect Method for Wideband FM Generation

Consider the following block diagram

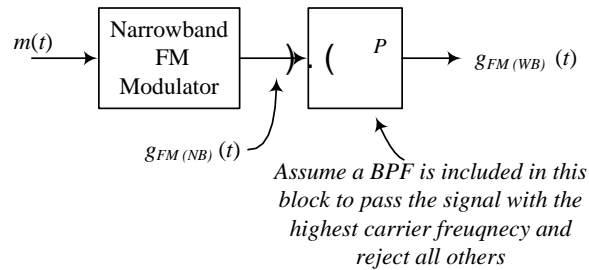

A narrowband FM signal can be generated easily using the block diagram of the narrowband FM modulator that was described in a previous lecture. The narrowband FM modulator generates a narrowband FM signal using simple components such as an integrator (an OpAmp), oscillators, multipliers, and adders. The generated narrowband FM signal can be converted to a wideband FM signal by simply passing it through a **nonlinear device** with exponent P . Both the carrier frequency and the frequency deviation Δf of the narrowband signal are increased by a factor P . Sometimes, the desired increase in the carrier frequency and the desired increase in Δf are different. In this case, we increase Δf to the desired value and use a **frequency shifter (multiplication by a sinusoid followed by a BPF)** to change the carrier frequency to the desired value.

Example 1 A narrowband FM modulator is modulating a message signal $m(t)$ with bandwidth 5 kHz and is producing an FM signal with the following specifications

$$f_{c1} = 300 \text{ kHz},$$

$$\Delta f_1 = 35 \text{ Hz}.$$

We would like to use this signal to generate a wideband FM signal with the following specifications

$$f_{c2} = 135 \text{ MHz},$$

$$\Delta f_2 = 77 \text{ kHz}.$$

Show the block diagram of several systems that will perform this function and specify the characteristics of each system

Solution: We see that the ratio of the carrier frequencies is

$$\frac{f_{c2}}{f_{c1}} = \frac{135 * 10^6}{300 * 10^3} = 450,$$

and the ratio of the frequency variations is $\frac{\Delta f_2}{\Delta f_1} = \frac{77 * 10^3}{35} = 2200$.

Therefore, we should feed the narrowband FM signal into a single (or multiple) non-linear device with a non-linearity order of $\Delta f_2/\Delta f_1 = 2200$. If we do this, the carrier frequency of narrowband FM signal will also increase by a factor of 2200, which is higher than what is required. This can easily be corrected by frequency shifting. If we feed the narrowband FM signal into a non-linear device of order f_{c2}/f_{c1} , we will get the correct carrier frequency but the wrong value for Δf . There is not a way of correcting the value of Δf for this signal without affecting the carrier frequency.

System 1

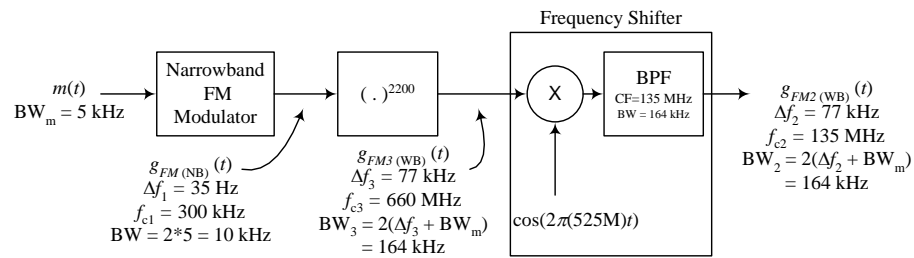

In this system, we are using a single non-linear device with an order of 2200 or multiple devices with a combined order of 2200. It is clear that the output of the non-linear device has the correct Δf but an incorrect carrier frequency which is corrected using a the frequency shifter with an oscillator that has a frequency equal to the difference between the frequency of its input signal and the desired carrier frequency. We could also have used an oscillator with a frequency that is the sum of the frequencies of the input signal and the desired carrier frequency. This system is characterized by having a frequency shifter with an oscillator frequency that is relatively large.

System 2

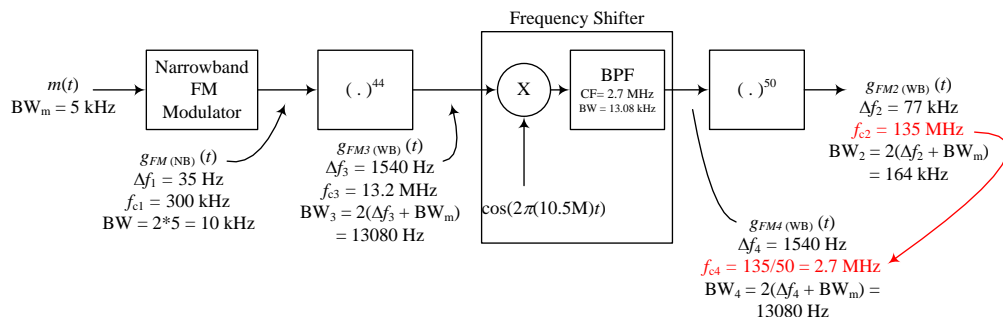

In this system, we are using two non-linear devices (or two sets of non-linear devices) with orders 44 and 50 ($44 \times 50 = 2200$). There are other possibilities for the factorizing 2200 such as 2×1100 , 4×550 , 8×275 , 10×220 , Depending on the available components, one of these factorizations may be better than the others. In fact, in this case, we could have used the same factorization but put 50 first followed by 44. We want the output signal of the overall system to be as shown in the block

diagram above, so we have to insure that the input to the non-linear device with order 50 has the correct carrier frequency such that its output has a carrier frequency of 135 MHz. This is done by dividing the desired output carrier frequency by the non-linearity order of 50, which gives 2.7 Mhz. This allows us to figure out the frequency of the required oscillator which will be in this case either $13.2 - 2.7 = 10.5$ MHz or $13.2 + 2.7 = 15.9$ MHz. We are generally free to choose whichever we like unless the available components dictate the use of one of them and not the other. Comparing this system with System 1 shows that the frequency of the oscillator that is required here is significantly lower (10.5 MHz compared to 525 MHz), which is generally an advantage.

System 3

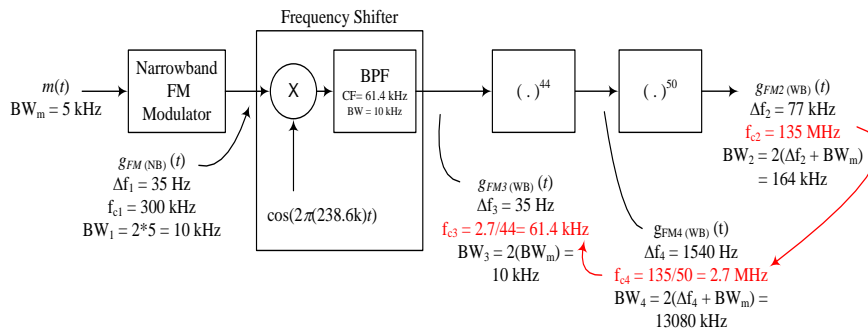

We also can bring the frequency shifter before all the non-linear devices and therefore reduce the frequency of the required oscillator to the minimum value by finding the required carrier frequency at the input of each non-linear device to insure that the carrier frequency of the final output of non-linear devices is the desired final carrier frequency.

Note that in general we require a very large factor n , if we do it in one stage and use excessive multiplication, we will get noise and distortion especially if f/f_m is not small enough.

Practical FM radio broadcasting

We start with 200kHz because it is easy to generate a stable frequency by a crystal oscillator at low frequency. $\Delta f = 25$ Hz. See the Figure below

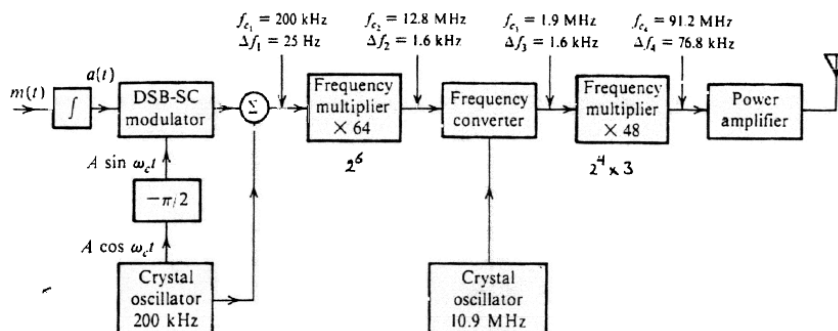

For more exercises on this WB FM generation method, refer to the problems at the end of Angle Modulation Chapter in your textbook.