

King Fahd University of Petroleum and Minerals

University Diploma Program
Electronic Equipment Maintenance
Lab Instructor: Muhammad Ajmal Khan

EET-027, Experiment # 2

Ohm's Law Verification and Wheatstone Bridge

Objectives:

1. To experimentally verify the ohm's law.
2. To experimentally study the balanced bridge circuit.

Apparatus:

DC Power Supply
DC current source
Few Resistors
Multimeter

THEORY:

Ohm's Law:

The voltage across an element is directly proportional to the current through it. The ohm's law can be written mathematically as:

$$V = IR$$

where R = Resistance

V = voltage across the resistance R

I = Current through the resistance R

Bridge Circuit:

Bridge circuits are used to convert impedance variations into voltage variations. One of the advantages of the bridge for this task is that it can be designed so the voltage produced varies around zero. This means that amplification can be used to increase the voltage level for increased sensitivity to variation of impedance. Another application of bridge circuit is in the precise static measurement of impedance.

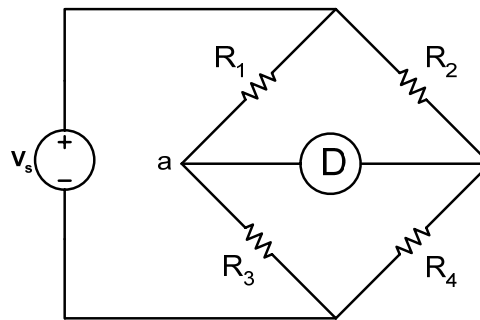

Figure 1: Bridge Circuit.

A basic type of bridge circuit is shown in figure 1, where four resistances are connected. A galvanometer or voltmeter is used to compare the potentials of points a and b of the circuit. If the current through the galvanometer is zero OR the potential difference across points a and b is zero then the bridge circuit is known as Balanced bridge circuit. In balanced bridge circuit the relation among the resistances is given as:

$$R_1 R_4 = R_2 R_3$$

PROCEDURE:

1. Ohm's Law:

1. Connect the circuit as shown in figure 2.
2. Set the DC voltage supply to 10 Volts.
3. Set the resistance R to 100 ohms.
4. Measure the voltage across the resistor and the current through the resistor and write the results in Table 1.
5. Determine the value of the resistance using Ohm's law $R=V/I$ and record in the Table 1.
6. Repeat step 2 to 5 for the other resistors (1000 ohms, 10 K ohms).

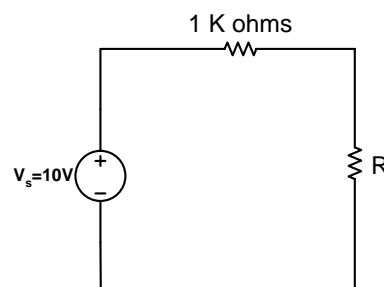

Figure 2: Ohm's Law

TABLE 1

Resistor (Nominal Value)	100 Ω	1 K Ω	10 K Ω
Ohm-meter Reading			
R = V / I			
Percent Deviation from Nominal Value			

Percent Deviation = (Nominal Value – Ohm-meter Reading) / (Nominal Value)

2. Balanced Bridge:

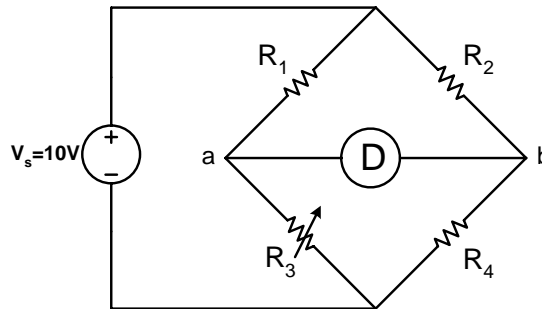

Figure 3: Balanced Bridge Circuit

1. Connect the circuit as shown in figure 3.
2. Set the DC voltage supply to 10 Volts.
3. Adjust the variable resistor R₃ until current through the volt-meter becomes zero.
4. Without altering R₃, remove it from the circuit and measure its resistance using an ohm-meter and write in the following table.

R₁	R₂	R₃	R₄

Verification of Balanced Bridge Principle:

$R_1 R_4$	$R_2 R_3$

Conclusions: