

# King Fahd University of Petroleum and Minerals

University Diploma Program  
Electronic Equipment Maintenance  
Lab Instructor: Muhammad Ajmal Khan

## EET-027, Experiment # 6

### Strain Gauge Application and Measurement of Unknown Load

#### Objectives:

1. To find the effect of loading on strain gauge resistance using Wheatstone bridge.
2. To find the effect of loading on strain gauge and find voltage difference using bridge circuit.
3. To find unknown load by using results and graphs obtained in part 1 and 2.

#### Apparatus:

Strain gauge  
Different Weights 1 kg, 2k, 5 kg.  
4-1/2 digit DVM.  
Wheatstone bridge  
Three resistances of 120 ohms.  
Power supply

#### Theory:

The strain gauge is a transducer employing electrical resistance variation to sense the strain produced by a force or weight. It is a very versatile detector for measuring weight, pressure, mechanical force, or displacement.

Strain, being a fundamental engineering phenomenon, exists in all matters at all times, due either to external loads or the weight of the matter itself. These strains vary in magnitude, depending upon the materials and loads involved. Engineers have worked for centuries in an attempt to measure strain accurately, but only in the last decade we have achieved much advancement in the art of strain measurement. The terms linear deformation and strain are synonymous and refer to the change in any linear dimension of a body, usually due to the

application of external forces. The strain of a piece of rubber, when loaded, is ordinarily apparent to the eye. However, the strain of a bridge strut as a locomotive passes may not be apparent to the eye. Strain as defined above is often spoken of as "total strain." Average unit strain is the amount of strain per unit length and has somewhat greater significance than does total strain. Strain gauges are used to determine unit strain, and consequently when one refers to strain, he is usually referring to unit strain. As defined, strain has units of inches per inch.

Strain gauges work on the principle that as a piece of wire is stretched, its resistance changes. A strain gauge of either the bonded or the unbonded type is made of fine wire wound back and forth in such a way that with a load applied to the material it is fastened to, the strain gauge wire will stretch, increasing its length and decreasing its cross-sectional area. The result will be an increase in its resistance, because the resistance,  $R$ , of a metallic conductor varies directly with length,  $L$ , and inversely with cross-sectional area,  $A$ . Mathematically the relationship is

$$R = \rho \frac{L}{A}$$

where  $\rho$  is a constant depending upon the type of wire,  $L$  is the length of the wire in the same units as  $\rho$ , and  $A$  is the cross-sectional area measured in units compatible with  $\rho$ .

Four properties of a strain gauge are important to consider when it is used to measure the strain in a material. They are:

1. Gauge configuration.
2. Gauge sensitivity.
3. Gauge backing material.
4. Method of gauge attachment.

The sensitivity of a strain gauge is a function of the conductive material, size, configuration, nominal resistance, and the way the gauge is energized.

Strain-gauge conductor materials may be either metal alloys or semiconductor material. Nickel-chrome-iron-alloys tend to yield high gauge sensitivities as well as have long gauge life. These alloys are quite good when used for dynamic strain measurements, but because of a high temperature coefficient, they are not as satisfactory for static strain measurements.

Copper-nickel alloys are generally use when temperatures are below 500 to 600°F. They are less sensitive to temperature changes and provide a less sensitive gauge factor than the nickel-chrome-iron alloys. Nickel-chrome alloys are useful in the construction of strain gauges for high temperature measurements.

In using electric strain gauges, two physical qualities are of particular interest, the change in gauge resistance and the change in length (strain). The relationship between these two variables is dimensionless and is called the "gauge factor" of the strain gauge and can be expressed mathematically as:

$$GF = \frac{\frac{\Delta R}{R}}{\frac{\Delta L}{L}}$$

$$GF = \frac{\Delta R/R}{Strain}$$

In this relationship R and L represent, respectively, the initial resistance and the initial length of the strain gauge wire, while  $\Delta R$  and  $\Delta L$  represent the small changes in resistance and length which occur as the gauge is strained along with the surface to which it is bonded. The gauge factor of a strain gauge is a measure of the amount of resistance change for a given strain and is thus an index of the strain sensitivity of the gauge. With all other variables remaining the same, the higher the gauge factor, the more sensitive the gauge and the greater the electrical output.

The most common type of strain gauge used today for stress analysis is the bonded resistance strain gauge shown below.

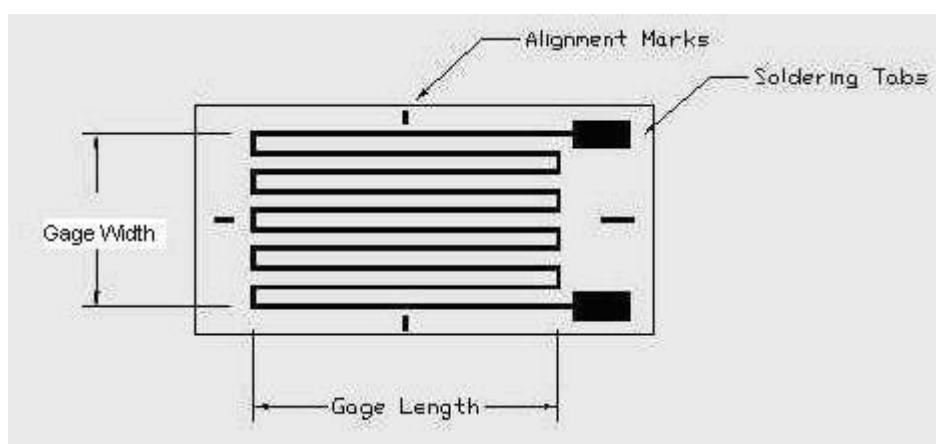

These gauges use a grid of fine wire or a constantan metal foil grid encapsulated in a thin resin backing. The gauge is glued to the carefully prepared test specimen by a thin layer of epoxy. The epoxy acts as the carrier matrix to transfer the strain in the specimen to the strain gauge. As the gauge changes in length, the tiny wires either contract or elongate depending upon a tensile or compressive state of stress in the specimen. The cross-sectional area will increase for compression and decrease in tension. Because the wire has an electrical resistance that is proportional to the inverse of the cross-sectional area,  $R \propto \frac{1}{A}$ , a measure of the change in resistance will produce the strain in the material.

## Procedure:

### (A) Using Wheatstone bridge:

1. Connect strain gauge with Wheatstone bridge and find the resistance of strain gauge with no load and record the value in the table.
2. Find the resistance of strain gauge with loads, 1 kg, 2 kg, 3 kg, 4 kg and 5 kg, through Wheatstone bridge and record the values in the table.

Load (kg)	Resistance (ohms)
0	
1	
2	
3	
4	
5	
Unknown	

3. Plot Resistance versus Load in the graph paper and write your conclusions.

**(B) Using Bridge Circuit:**

1. Connect strain gauge with the bridge circuit as shown the following figure. Set the power supply to 10 Volts and all three resistances are 120 ohms.

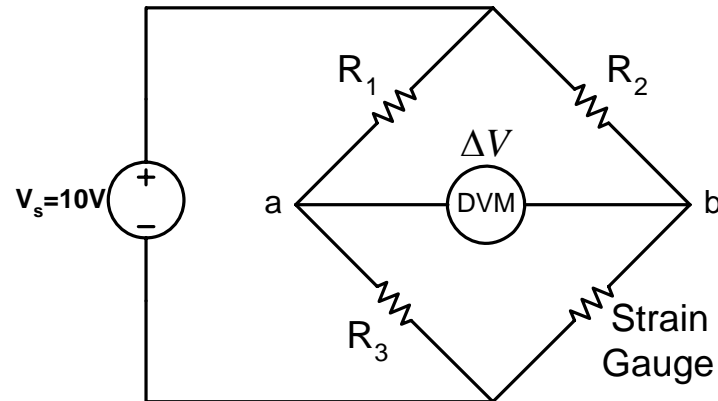

2. Find the voltage difference ( $\Delta V$ ) across nodes “a” and “b” using digital volt-meter (DVM) with no load and record the value in the table.
3. Find the voltage difference ( $\Delta V$ ) using digital volt-meter (DVM) with loads, 1 kg, 2 kg, 3 kg, 4 kg and 5 kg, and record the values in the following table.

Load (kg)	Voltage Difference (mV) $\Delta V$
0	
1	
2	
3	
4	
5	
Unknown	

4. Plot the voltage difference  $\Delta V$  versus Load in the graph paper and write your conclusions.

**(C) Find Unknown Load using Graphs:**

1. Find the unknown load using resistance versus load graph (obtained in part A).

**Unknown Load :** \_\_\_\_\_ kg.

2. Find the voltage difference using voltage difference versus load graph (obtained in part B).

**Unknown Load :** \_\_\_\_\_ kg.

**Conclusions:**