

## Experiment # 4

# MAGNETIC FIELD OUTSIDE A STRAIGHT CONDUCTOR

---

### OBJECTIVE

To obtain the magnetic field due to current in a straight conductor as a function of the current and as a function of the normal distance from the conductor. Also the magnetic field due to current passing through two straight conductors is to be obtained.

**WARNING: THIS EXPERIMENT INVOLVES HIGH CURRENT (100A) AND HIGH TEMPERATURE. DO NOT TOUCH THE CONDUCTOR OR THE TRANSFORMER.**

### EQUIPMENT REQUIRED

1. A straight conductor.
2. Teslameter with an axial probe.
3. Ammeter.
4. Multimeter.
5. Transformer.
6. Current transformer (100:1 ratio).
7. Power supply.

### INTRODUCTION

It is known that the current passing through a long straight conductor (see figure 1) produces a magnetic flux density given by:

$$|\vec{B}| = \frac{\mu_o I}{2\pi r} \dots\dots\dots (1)$$

It can also be easily shown that  $\vec{B}$  due to current in two long and parallel straight conductors is given by:

$$|\vec{B}| = \frac{\mu_o I}{2\pi x} + \frac{\mu_o I}{2\pi(x - a)} \dots\dots\dots (2)$$

$$|\vec{B}| = \frac{\mu_o I}{2\pi x} - \frac{\mu_o I}{2\pi(x - a)} \dots\dots\dots (3)$$

where  $a$  is the distance between the conductors. Equation (2) applies to the case when the currents flow in the same direction and equation (3) applies when the currents flow in the opposite directions as shown in figures 2 (a) and (b) respectively.

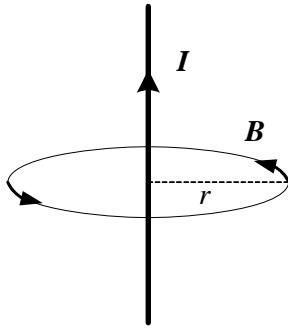

Figure 1: Magnetic field around a straight conductor

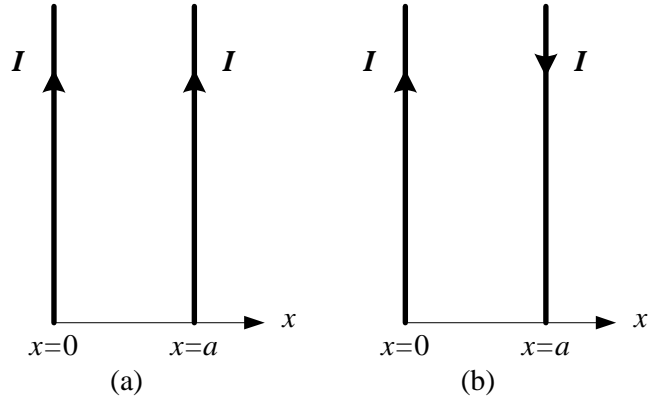

Figure 2: Two parallel straight conductors with (a) currents in same directions (b) currents in opposite directions

### EXPERIMENTAL SETUP AND PROCEDURE

The experimental set up is shown in figure 3. The magnetic field readings will be taken from the voltmeter which is connected to the teslameter with appropriate calibration.

The teslameter must first be calibrated. For calibration it does not matter if a magnetic field is present or not. The calibration procedure is as follows:

- a) Adjust the multimeter knob to the 3V position (choose AC).
- b) Push the DC button of the teslameter.
- c) Push the "Eichen" button of the teslameter.
- d) Turn the "Eichen" knob until the multimeter reads exactly 3 volts.
- e) Release the "Eichen" button. The teslameter is now calibrated.

Turn the knob of the teslameter to the 3mT position and keep it set at this position throughout the experiment. This makes 3mT equivalent to 3V or 1mT = 1 V. Push the AC button of the teslameter.

The power supply output (0...15V~, 5A) is connected to the upper most and lower most ports of the transformer for maximum power output.

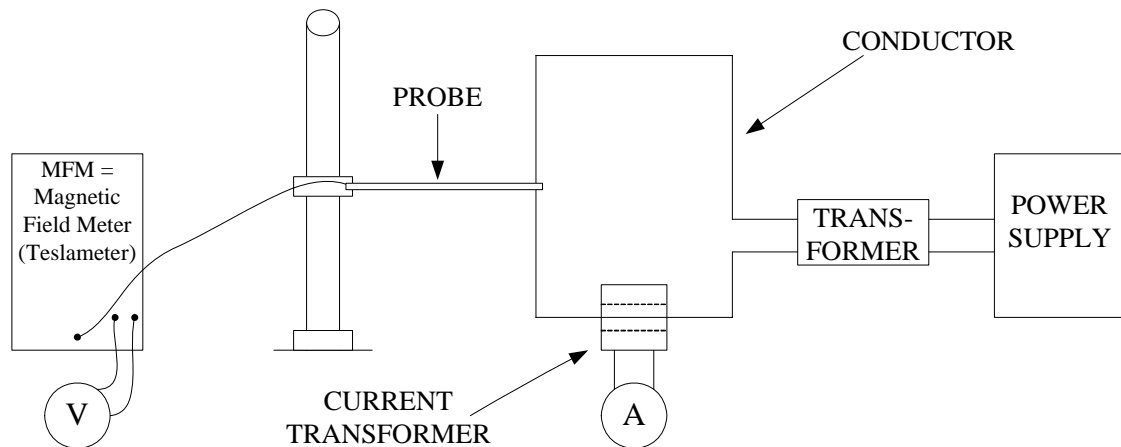

Figure 3: Experimental set-up

1. Fix the distance between the tip of the probe and the conductor to 1 cm (keep the probe tip near the middle of the vertical conductor). Change the current through the conductor and measure the resulting  $B$  field. (Keep the tip of the probe in the plane of the conducting loop. Also keep the probe perpendicular to the plane of the loop throughout this experiment).
2. Fix the current to 100A and change the distance between the probe and the conductor. Record the magnetic field at several distances to produce a smooth curve.

**Calibration** → \_\_\_\_\_

**Table 1: Magnetic Field variation with Current** ( $r = 1 \text{ cm}$ )

| Current ' $I$ '<br>(A) | Magnetic Field ' $B$ ' (mT) |             | Percentage<br>Error |
|------------------------|-----------------------------|-------------|---------------------|
|                        | Experimental                | Theoretical |                     |
| 0                      |                             |             |                     |
| 10                     |                             |             |                     |
| 20                     |                             |             |                     |
| 30                     |                             |             |                     |
| 40                     |                             |             |                     |
| 50                     |                             |             |                     |
| 60                     |                             |             |                     |
| 70                     |                             |             |                     |
| 80                     |                             |             |                     |
| 90                     |                             |             |                     |
| 100                    |                             |             |                     |

**Table 2: Magnetic Field variation with Distance ( $I = 100$  A)**

| Distance ' $r$ '<br>(cm) | Magnetic Field ' $B$ ' (mT) |             | Percentage<br>Error |
|--------------------------|-----------------------------|-------------|---------------------|
|                          | Experimental                | Theoretical |                     |
| 1                        |                             |             |                     |
| 2                        |                             |             |                     |
| 3                        |                             |             |                     |
| 4                        |                             |             |                     |
| 5                        |                             |             |                     |
| 6                        |                             |             |                     |
| 7                        |                             |             |                     |
| 8                        |                             |             |                     |
| 9                        |                             |             |                     |
| 10                       |                             |             |                     |

**QUESTIONS FOR DISCUSSION**

1. Plot a graph of the experimental relation between the current in the wire and the resulting magnetic field. Compare with the theoretical results based on equation (1). (Note: plot both results on top of each other).
2. Plot a graph of the experimental relation between the magnetic field of the wire and distance. Compare with the theoretical results based on equation (1). (Note: plot both results on top of each other).
3. Based on your experimental curve for a single wire, sketch the expected field from the structures in figures 2 (a) and (b).
4. How can you experimentally determine the direction of the magnetic field due to the straight line?