

Exam 2-991

Q1 It takes 2.0 J of work to stretch a spring 10 cm from its unstressed length. Calculate the length this spring will stretch from its unstressed (normal) length when a mass of 980 g is hung from it.

- A1: 2.4 cm
- A2: 2.0 cm
- A3: 2.8 cm
- A4: 3.2 cm
- A5: 3.6 cm

Q2 A box is moving with a speed of 9.10 m/s to the right. After it has moved a distance = d on a rough horizontal surface ($\mu = 0.6$) its speed is reduced to 3.69 m/s. Find the value of d.

- A1: 5.88 m
- A2: 3.22 m
- A3: 2.33 m
- A4: 8.44 m
- A5: 4.00 m

Q3 An escalator, moving with constant speed, is used to take 20 people (60 kg each) per minute from ground floor of Al-Rashed Mall to the first floor, 5 m above (see Fig (1)). Neglecting friction, the average power required is:

- A1: 980 W
- A2: 1960 W
- A3: 100 W
- A4: 200 W
- A5: 400 W

Q4 A simple pendulum consists of a 2.0 kg mass attached to a string of length = 1.0 m. It is released from rest at X as shown in Fig (2). Its speed at the lowest point Y is:

- A1: 3.1 m/s
- A2: 4.4 m/s
- A3: 1.6 m/s
- A4: 5.2 m/s
- A5: 0.0 m/s

Q5 A 3.0 kg mass starts from rest and slides a distance $d = 1.0$ m down a frictionless 60 deg incline, where it contacts an unstressed spring as in Fig (3). The mass slides an additional 35 cm as it is brought momentarily to rest by compressing the spring. Find the spring constant of the spring.

- A1: 561 N/m
- A2: 262 N/m
- A3: 363 N/m
- A4: 664 N/m
- A5: 465 N/m

Q6 A projectile of mass 0.50 kg is fired with an initial speed of 10 m/s at an angle of 60 deg above the horizontal. The total mechanical energy (relative to ground level) of the projectile at its highest point is:

- A1: 25.0 J
- A2: 18.8 J
- A3: 6.25 J
- A4: 50.0 J
- A5: 0.0 J

Q7 For an isolated system, an inelastic collision is one in which:

- A1: momentum is conserved but kinetic energy is not conserved
- A2: momentum is not conserved but kinetic energy is conserved
- A3: momentum is not conserved but mass is conserved
- A4: neither momentum nor kinetic energy is conserved
- A5: the total impulse equals the change in kinetic energy

Q8 A 2.00 kg object is moving with a velocity of 20.0 m/s in (+x) direction. Under the influence of a force the object starts to move with velocity of 20.0 m/s along (+y) direction. Find the magnitude of the impulse of the force.

- A1: 56.6 N.s
- A2: 40.0 N.s
- A3: 0 N.s
- A4: 28.3 N.s

A5: 20.0 N. s

Q9 Three identical particles each of mass = 1 kg are placed in the xy plane. The position vector of the first is $r_1 = (1i + 4j)$ m and the second is $r_2 = (3i + 1j)$ m. What would be the position vector of the third particle if the center of mass of the three particles were at (3 m, 3 m)?

A1: $r_3 = (5i + 4j)$ m

A2: $r_3 = (3i - 1j)$ m

A3: $r_3 = (1i + 2j)$ m

A4: $r_3 = (2i - 6j)$ m

A5: $r_3 = (4i + 3j)$ m

Q10 A 2.00 kg object moving with a speed of 3.00 m/s collides with a 1.00 kg object initially at rest. Immediately after collision, the 2.00 kg object has a velocity of 1.73 m/s directed 30 deg from its initial direction of motion. What is the speed of the 1.00 kg just after collision?

A1: 3.46 m/s

A2: 1.73 m/s

A3: 3.00 m/s

A4: 1.50 m/s

A5: 6.00 m/s

Q11 A disk of radius 20 cm rotating at 42 rad/sec stops (assume constant deceleration) after 10 sec. Through how many radians does the disk turn during this time?

A1: 210 rad

A2: 320 rad

A3: 150 rad

A4: 440 rad

A5: 900 rad

Q12 A disk is rotating about an axel through its center O when two forces $F_1 = 10$ N and $F_2 = 15$ N are applied on it as shown in Fig (4). The moment of inertia of the disk about O is $0.036 \text{ kg}\cdot\text{m}^2$. If the system starts from rest, find the angular speed at time = 3.0 s.

A1: 100 rad/s

A2: 130 rad/s

A3: 80 rad/s

A4: 25 rad/s

A5: 15 rad/s

Q13 A uniform rod of length $L = 0.98$ m and mass $M = 3.0$ kg is free to rotate on a frictionless pin through one end (Fig. (5)). The rod has an angular speed of 4.0 rad/s when it was in the horizontal position. What is the angular speed at its lowest position?

A1: 6.8 rad/s

A2: 3.4 rad/s

A3: 5.5 rad/s

A4: 4.0 rad/s

A5: 8.8 rad/s

Q14 The four particles in Fig (6) are connected by rigid rods of negligible mass. Calculate the moment of inertia of this system about the x axis.

A1: $63 \text{ kg}\cdot\text{m}^2$

A2: $23 \text{ kg}\cdot\text{m}^2$

A3: $93 \text{ kg}\cdot\text{m}^2$

A4: $34 \text{ kg}\cdot\text{m}^2$

A5: $72 \text{ kg}\cdot\text{m}^2$

Q15 At a certain instant the position vector of a particle is given by $r = (2i)$ m. The linear momentum $p = (3j + k)$ kg. m/s. The angular momentum of the particle is:

A1: $(-2j + 6k)$ kg. m²/s

A2: $(3j)$ kg. m²/s

A3: $(5j + k)$ kg. m²/s

A4: $(2j + 5k)$ kg. m²/s

A5: 0 kg. m²/s

Q16 A particle of mass 2.0 kg moves in a horizontal circle of radius $R = 0.5$ m. At a point Q, the velocity of the particle is 4.0 m/s in the (+y) direction. Determine the angular momentum of the particle about the point P as shown in Fig (7).

A1: $(8.0 k)$ kg. m²/s

A2: $(4.0 j)$ kg. m²/s

- A3: (8.0 j) kg. m**2/s
A4: (4.0 k) kg. m**2/s
A5: 0 kg. m**2/s

Q17 A solid sphere of mass = 20 kg and radius = 1.5 m rolls from rest without slipping down a rough inclined plane ($\mu=0.3$) that makes an angle = 30 deg with the horizontal (see Fig (8)). Calculate the total kinetic energy of the rolling sphere at the bottom of the inclined plane.

- A1: 4900 J
A2: 2200 J
A3: 1230 J
A4: 4010 J
A5: 0 J

Q18 A disk (A) of mass = 2.00 kg and radius = 30.0 cm rotates with angular velocity = 20.0 rad/s. Another disk (B) of mass = 1.00 kg and radius = 10.0 cm rotates with angular velocity = 20.0 rad/s in the opposite direction is dropped onto disk (A) (see Fig (9)). Calculate the final angular velocity of the two disks together.

- A1: 17.9 rad/s
A2: 6.70 rad/s
A3: 15.2 rad/s
A4: 12.5 rad/s
A5: 20.0 rad/s

Q19 A uniform ladder (length = 5.00 m, mass = 20.0 kg) is leaning against a frictionless wall at an angle of 53 deg above the horizontal. A 40.0 kg boy climbs 2.00 m up the ladder (see Fig (10)). What is the magnitude of the friction force exerted on the ladder by the floor?

- A1: 192 N
A2: 250 N
A3: 375 N
A4: 521 N
A5: 124 N

Q20 Fig (11) shows a uniform horizontal beam (length = 10 m, mass = 25 kg) that is pivoted at the wall, with its far end supported by a cable that makes an angle of 50 deg with the horizontal. If a person (mass = 60 kg) stands 3.0 m from the pivot, what is the tension in the cable?

- A1: 390 N
A2: 200 N
A3: 830 N
A4: 420 N
A5: 300 N

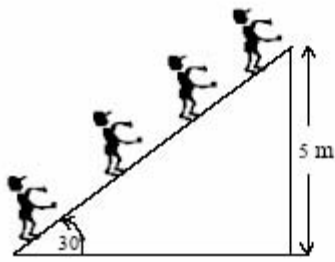

Figure 1

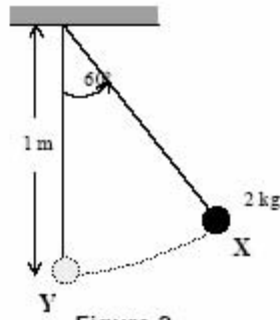

Figure 2

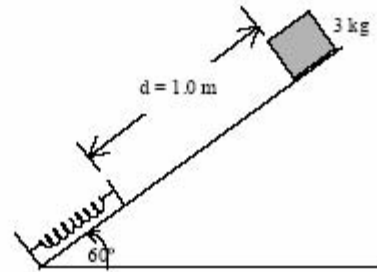

Figure 3

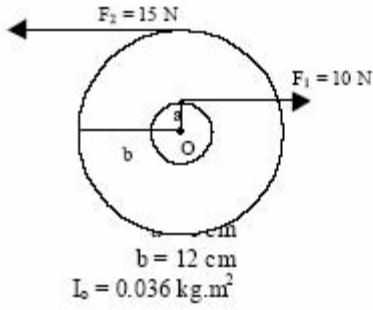

Figure 4

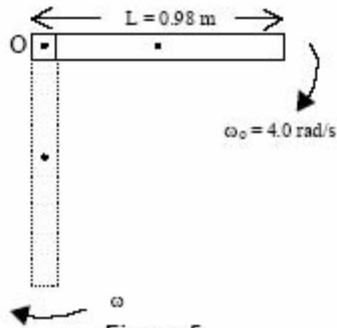

Figure 5

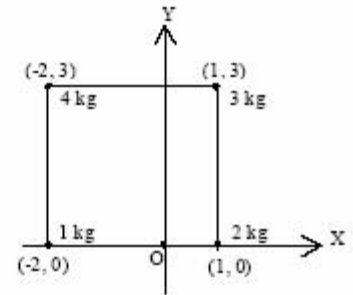

Figure 6

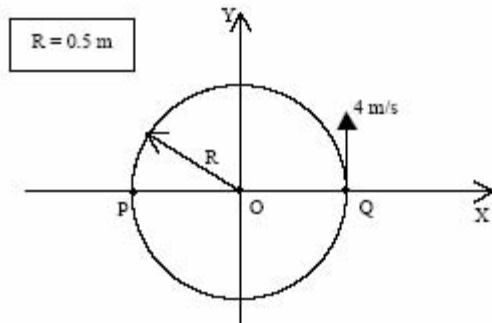

Figure 7

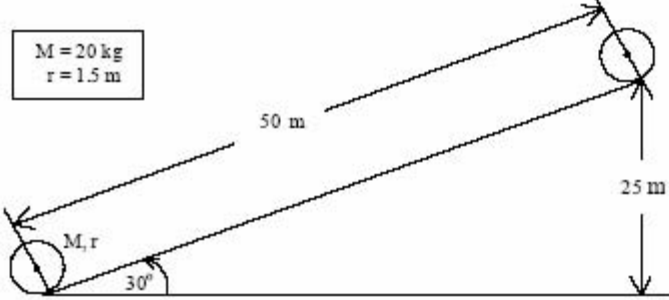

Figure 8

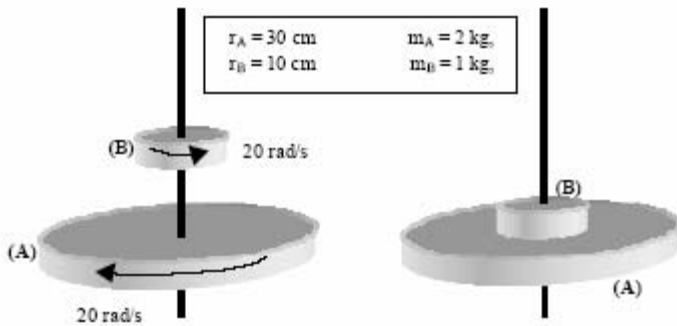

Figure 9

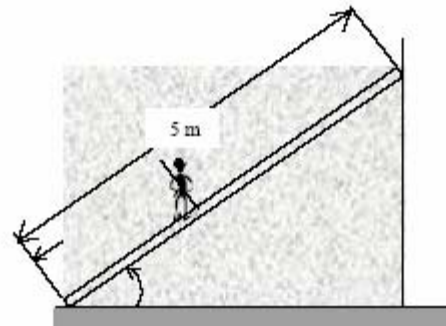

Figure 10

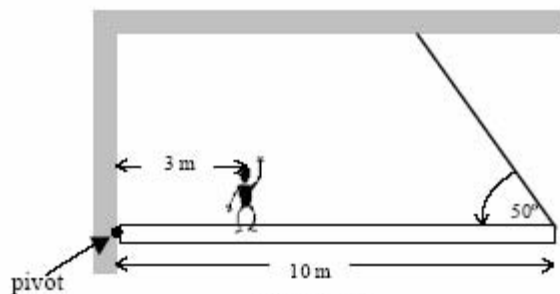

Figure 11

$$I_{cm} \text{ (solid sphere)} = \frac{2}{5} MR^2$$

$$I_{cm} \text{ (cylinder)} = \frac{1}{2} MR^2$$

$$I_{cm} \text{ (rod)} = \frac{1}{12} ML^2$$

$$I_{one\ end} \text{ (rod)} = \frac{1}{3} ML^2$$