

Non-Accelerated Motion

1. The sketch shows a ball rolling at constant velocity along a level floor. The ball rolls from the first position shown to the second in 1 second. The two positions are 1 meter apart. Sketch the ball at successive 1-second intervals all the way to the wall (neglect resistance).

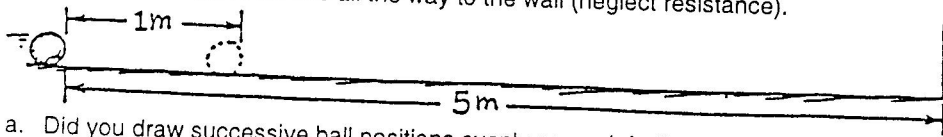

- a. Did you draw successive ball positions evenly spaced, farther apart, or closer together? Why?
- b. The ball reaches the wall with a speed of _____ m/s and takes a time of _____ seconds.
2. Table I shows data of sprinting speeds of some animals. Make whatever computations are necessary to complete the table.

Table I

ANIMAL	DISTANCE	TIME	SPEED
CHEETAH	75 m	3 s	25 m/s
GREYHOUND	160 m	10 s	
GAZELLE	1 km		100 km/h
TURTLE		30 s	1 cm/s

Accelerated Motion

3. An object starting from rest gains a speed $v = at$ when it undergoes uniform acceleration. The distance it covers is $d = 1/2 at^2$. Uniform acceleration occurs for a ball rolling down an inclined plane. The plane below is tilted so a ball picks up a speed of 2 m/s each second; then its acceleration $a = 2 \text{ m/s}^2$. The positions of the ball are shown at 1-second intervals. Complete the six blank spaces for distance covered, and the four blank spaces for speeds.

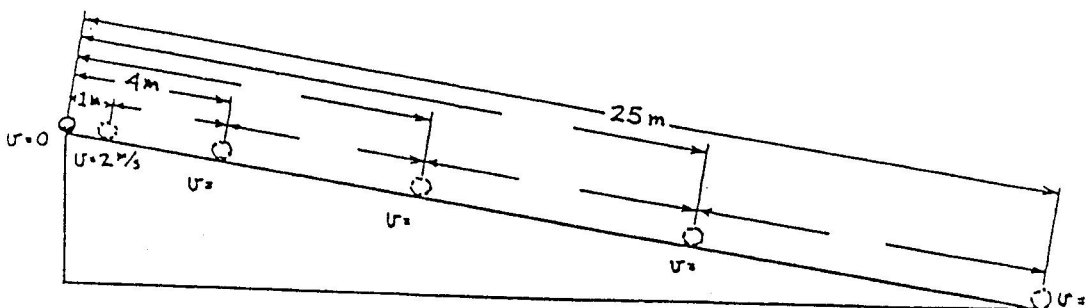

- a. Do you see that the total distance from the starting point increases as the square of the time? This was discovered by Galileo. If the incline were to continue, predict the ball's distance from the starting point for the next 3 seconds.
- b. Note the increase of distance between ball positions with time. Do you see an odd-integer pattern (also discovered by Galileo) for this increase? If the incline were to continue, predict the successive distances between ball positions for the next 3 seconds.