

- Q1 Q0 The system in Fig 2 is in equilibrium. A mass (M) of 5.0 kg
 13 Q0 hangs from the end of the uniform beam of mass = 10.0 kg.
 Q0 The tension in the cable is:
 Q0
 A1 190 N
 A2 210 N
 A3 69 N
 A4 51 N
 A5 98 N
 Q0
- Q2 Q0 Two scales are 2.0 m apart. A uniform 40 kg beam of the same
 13 Q0 length is placed on top of them (see Fig 3). A 10 kg block is
 Q0 placed on the beam after which the right scale reads 22 kg and
 Q0 the left scale reads 28 kg. How far from the right scale is the
 Q0 center of gravity of the block located?
 Q0
 A1 1.6 m
 A2 0.2 m
 A3 1.3 m
 A4 1.4 m
 A5 0.8 m
 Q0
- Q3 Q0 A 500 kg mass is hung from the ceiling with a steel wire. The
 13 Q0 wire has a length = 45.0 cm, radius = 4.00 mm and has negligible
 Q0 mass. Calculate the change in the length of the wire.
 Q0 (Youngs modulus of steel $E = 2.00 \times 10^{11} \text{ N/m}^2$)
 Q0
 A1 0.22 mm
 A2 0.15 mm
 A3 0.75 mm
 A4 0.50 mm
 A5 0.05 mm
 Q0
- Q4 Q0 A space ship is going from the Earth to the Moon along the line
 14 Q0 joining their centers. At what distance from the center of the
 Q0 Earth will the net gravitational force on the space ship be zero?
 Q0 Assume that $M_e = 81 M_m$, where M_e is the mass of the Earth
 Q0 and M_m is the mass of the Moon. (The distance from the center of
 Q0 the Earth to the center of the Moon is $3.8 \times 10^5 \text{ km}$).
 Q0
 A1 $3.4 \times 10^5 \text{ km}$
 A2 $3.8 \times 10^5 \text{ km}$
 A3 $3.0 \times 10^5 \text{ km}$
 A4 $4.3 \times 10^5 \text{ km}$
 A5 $1.9 \times 10^5 \text{ km}$
 Q0
- Q5 Q0 A satellite circles the Earth at an altitude equal to 3 times
 14 Q0 the radius of Earth. Find the gravitational acceleration due
 Q0 to Earth at the satellite.
 Q0 (g on the surface of Earth is 9.8 m/s^2)
 Q0
 A1 0.61 m/s^2
 A2 0.22 m/s^2
 A3 9.8 m/s^2
 A4 3.3 m/s^2
 A5 0.0 m/s^2
 Q0
- Q6 Q0 Two moons orbit a planet in circular orbits. Moon (A) has

PHYS101 - FINAL EXAM – FIGURES Term-031

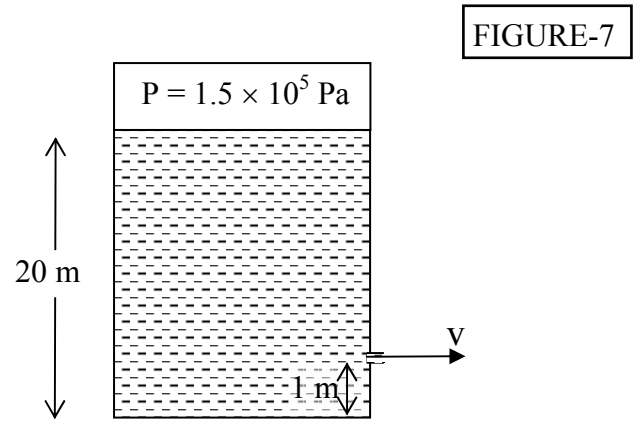
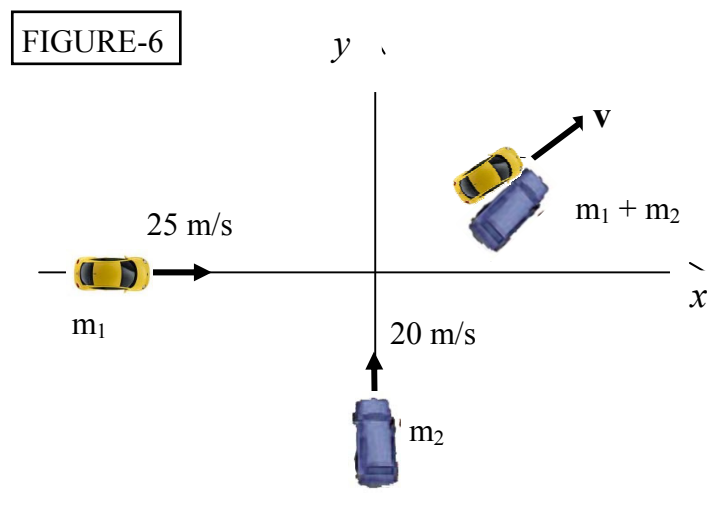
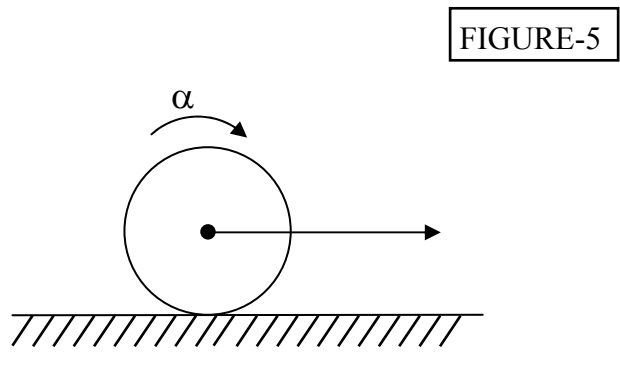
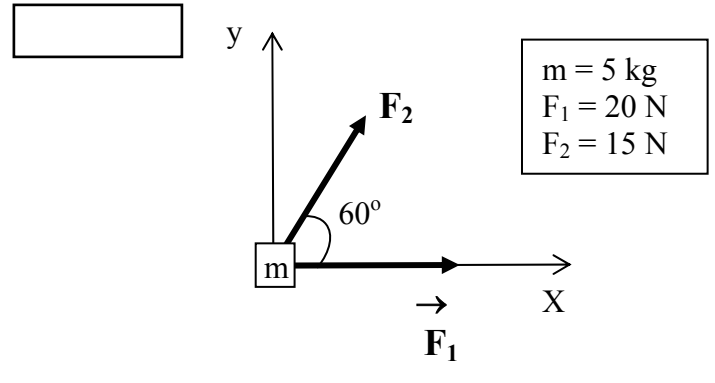
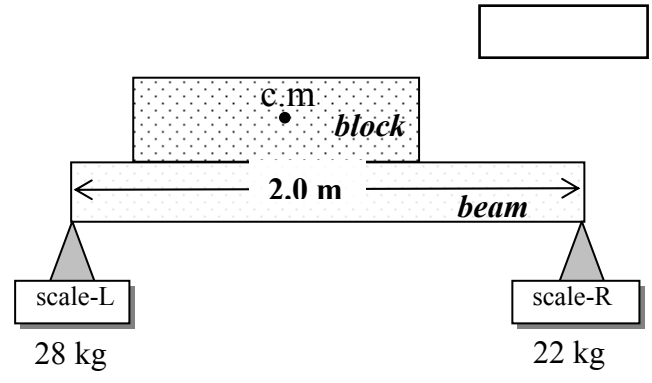
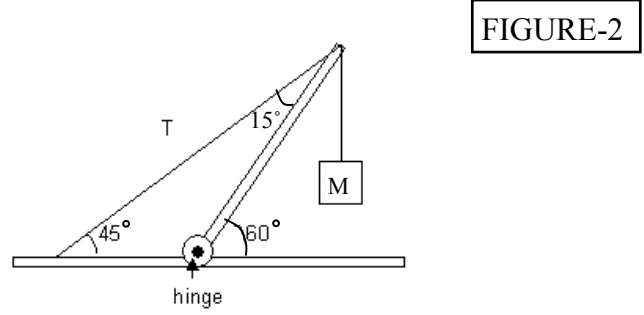
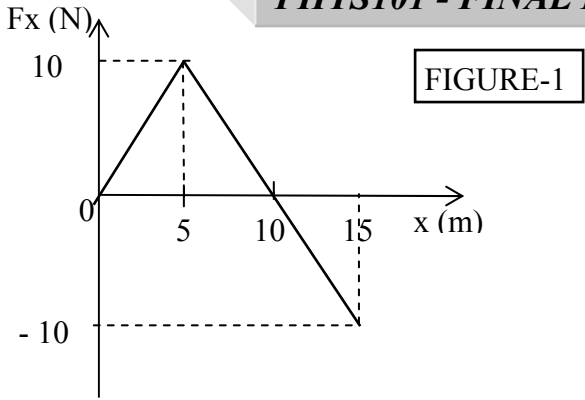

- 14 Q0 orbital radius R and moon (B) has orbital radius $4R$. Moon A takes
 Q0 20 days to complete its orbit. How long does it take moon (B) to
 Q0 complete its orbit?
 Q0
 A1 160 days
 A2 20 days
 A3 80 days
 A4 320 days
 A5 100 days
 Q0
- Q7 Q0 What is the escape speed from the surface of a planet whose
 14 Q0 radius is 5000 km, if the gravitational acceleration on its
 Q0 surface is 4.0 m/s^2 ?
 Q0
 A1 6.3 km/s
 A2 2.8 km/s
 A3 2.0 km/s
 A4 4.0 km/s
 A5 8.0 km/s
 Q0
- Q8 Q0 Two different solid metal pieces experience the same buoyant
 15 Q0 force when completely submerged in the same liquid. Which of the
 Q0 following statements is CORRECT?
 Q0
 A1 Their volumes are equal.
 A2 Their densities are equal.
 A3 Their masses are equal.
 A4 They displace different volumes of the liquid.
 A5 All of the other answers are wrong.
 Q0
- Q9 Q0 How deep into a lake would you have to dive so that the increase
 15 Q0 in pressure you experience is one atmosphere?
 Q0 (The density of water = 10^3 kg/m^3).
 Q0 (1 atmosphere = $1.01 \times 10^5 \text{ N/m}^2$)
 Q0
 A1 10.3 m
 A2 9.8 m
 A3 4.9 m
 A4 2.01 m
 A5 100 m
 Q0
- Q10 Q0 A pipe 16 cm in diameter is used to fill a tank of volume
 15 Q0 5000 liters in 5 minutes. What is the speed at which the water
 Q0 leaves the pipe? (1 liter = 10^{-3} m^3)
 Q0
 A1 50 m/min
 A2 40 m/min
 A3 200 m/min
 A4 25 m/min
 A5 100 m/min
 Q0
- Q11 Q0 Consider a large, closed, cylindrical tank with oil inside it.
 15 Q0 There is a small hole at a height of 1 m from the bottom of the
 Q0 tank. The air above the oil is maintained at a pressure
 Q0 $1.5 \times 10^5 \text{ Pa}$ (see Fig 7). Find the speed at which oil leaves
 Q0 the hole, when the oil level is 20 m above the bottom of the
 Q0 tank. (The density of oil is 850 kg/m^3).
 Q0
 A1 22 m/s
 A2 11 m/s

- A3 44 m/s
- A4 33 m/s
- A5 55 m/s

Q0

Q12Q0 A 5.0 kg mass stretches a spring by 10 cm when the mass is
16 Q0 attached to the spring. The mass is then displaced downward
Q0 an additional 5.0 cm and released. Its position (y) in m from
Q0 its equilibrium position as a function of time (t) is:

Q0

- A1 $y = 0.05 \cos (10 * t)$
- A2 $y = 0.10 \cos (10 * t)$
- A3 $y = 0.10 \sin (10 * t)$
- A4 $y = 0.10 \cos (5 * t)$
- A5 $y = 0.05 \sin (5 * t)$

Q0

Q13Q0 A particle (m = 0.2 kg) is attached to a spring. The motion of
16 Q0 the particle is described by $x = 0.10 \cos (10*t + \pi/3)$
Q0 where x is m and t is in s. What is the mechanical energy of
Q0 the particle?

Q0

- A1 0.1 J
- A2 0.8 J
- A3 0.6 J
- A4 1.0 J
- A5 10 J

Q0

Q14Q0 The frequency of small oscillations of a simple pendulum of
16 Q0 length (L) on the surface of Earth is (f). What will be its
Q0 frequency on the surface of the Moon if we increase its length
Q0 to become (2L)? (Take: $g(\text{Moon}) = 0.17 g(\text{Earth})$)

Q0

- A1 $0.29 * f$
- A2 $3.4 * f$
- A3 f
- A4 $2*f$
- A5 $0.085 * f$

Q0

Q15Q0 A mass m = 2 kg is attached to a spring having a force constant
16 Q0 k = 300 N/m. The mass is displaced from its equilibrium position
Q0 and released. Its period of oscillation (in s) is
Q0 approximately

Q0

- A1 0.5
- A2 10
- A3 2.0
- A4 0.01
- A5 0.08

Q0

Q16Q0 The average density of blood is $1.06 \times 10^{**3} \text{ kg/m}^{**3}$. If you
1 Q0 donate one pint of blood, what is the mass of the blood you
Q0 have donated, in grams?
Q0 (1 pint = 1/2 Liter, 1 Liter = 1000 cm^{**3})

Q0

- A1 530
- A2 $5.30 \times 10^{**3}$
- A3 0.530
- A4 $5.30 \times 10^{**5}$
- A5 1060

Q0

Q17Q0 A car travels along a straight road with a speed of $v_1 = 15 \text{ m/s}$

2 Q0 for half the distance between two cities and with a speed
Q0 $v_2=30$ m/s for the other half. What is the average velocity of
Q0 the car for the entire trip?

Q0

A1 20.0 m/s

A2 22.5 m/s

A3 25.0 m/s

A4 18.5 m/s

A5 24.0 m/s

Q0

Q18Q0 Which of the following is a unit vector?

3 Q0

A1 $\mathbf{j} \times \mathbf{i}$

A2 $(1/2) (\mathbf{i} - \mathbf{j})$

A3 $(1/2) (\mathbf{i} + \mathbf{j})$

A4 $(1/\sqrt{2}) (\mathbf{i} + \mathbf{j} + \mathbf{k})$

A5 $0.3 \mathbf{j} + 0.4 \mathbf{k}$

Q0

Q19Q0 An object (A) is shot horizontally with a speed V_0 from the top
4 Q0 of a building of height (h). It takes a time t_A for it to reach
Q0 the ground. Another object (B) is dropped from the same height
Q0 and reaches the ground in time t_B . Which of the following
Q0 statements is CORRECT?

Q0

A1 $t_A = t_B$

A2 $t_A > t_B$

A3 $t_A < t_B$

A4 Both objects will hit the ground with the same speed.

A5 The acceleration of object (A) is zero.

Q0

Q20Q0 Two forces $F_1 = 20$ N and $F_2 = 15$ N, act on a block of mass
5 Q0 5.0 kg as shown in Fig 4. Find the magnitude of the
Q0 acceleration of the block.

Q0

A1 6.1 m/s^2

A2 5.5 m/s^2

A3 2.6 m/s^2

A4 1.3 m/s^2

A5 8.1 m/s^2

Q0

Q21Q0 A box slides down an inclined plane at constant velocity.

6 Q0 Which of the following statements is CORRECT?

Q0

A1 A frictional force must be acting on it.

A2 A net force is acting on it.

A3 Its acceleration is half the acceleration of gravity.

A4 Gravity is not acting on it.

A5 Its potential energy is constant.

Q0

Q22Q0 Fig 1 shows a force F_x , directed along the x-axis, acting on
7 Q0 a particle. The particle begins from rest at $x = 0$. What is
Q0 particle's position when it has the greatest speed?

Q0

A1 10 m

A2 5 m

A3 15 m

A4 8 m

A5 2 m

Q0

Q23Q0 A particle moves under the influence of a single conservative

ch8Q0 force. At point (A) the potential energy associated with the
Q0 conservative force is +40 J. As the particle moves from (A) to
Q0 (B), the force does +25 J of work on the particle. What is the
Q0 value of the potential energy at point B?

Q0

A1 +15 J

A2 +65 J

A3 +35 J

A4 +45 J

A5 +40 J

Q0

Q24Q0 A 5.0 kg block starts up a 30 degrees incline

8 Q0 with 150 J of kinetic energy. How far will it

Q0 slide up the incline if the coefficient of kinetic

Q0 friction between the block and the incline is 0.30?

Q0

A1 4.0 m

A2 3.5 m

A3 7.0 m

A4 8.2 m

A5 2.4 m

Q0

Q25Q0 Block (A) of mass 0.2 kg, travelling on a frictionless

9 Q0 horizontal plane at 3.0 m/s, hits block (B) of mass 0.4 kg which

Q0 is initially at rest. After the collision the center of mass of

Q0 the two blocks has a speed of:

Q0

A1 1.0 m/s

A2 2.0 m/s

A3 3.0 m/s

A4 0 m/s

A5 4.0 m/s

Q26Q0 A 1500 kg car travelling east with a speed of 25 m/s collides

10 Q0 with a 2500 kg van traveling north with a speed of 20 m/s at

Q0 an intersection. The two cars stick together after the collision

Q0 and move in the direction shown in Fig 6. What is the speed of

Q0 the two cars after the collision?

Q0

A1 15.6 m/s

A2 20.8 m/s

A3 17.7 m/s

A4 18.2 m/s

A5 25.1 m/s

Q0

Q27Q0 A certain force accelerates a 5 kg object from a velocity of

10 Q0 $(2\mathbf{i}+4\mathbf{j})$ m/s to a velocity $(-2\mathbf{i}+4\mathbf{j})$ m/s in 2 s. Find the average

Q0 force acting on the object during this time interval.

Q0

A1 $(-10 \mathbf{i})$ N

A2 $(10 \mathbf{j})$ N

A3 $(-20 \mathbf{i})$ N

A4 $(20 \mathbf{j})$ N

A5 zero

Q0

Q28Q0 Increasing the angular speed of a rotating body will NOT cause

11 Q0 an increase in:

Q0

A1 the rotational inertia

A2 angular momentum

A3 linear speed

A4 rotational kinetic energy
A5 translational kinetic energy
Q0

Q29Q0 A merry-go-round, of radius $R=2.0$ m and rotational inertia
12 Q0 $I = 250 \text{ kg}\cdot\text{m}^2$, is rotating at 19 rev/min about its axle.
Q0 A 25 kg boy jumps onto the edge of the merry-go-round. What is
Q0 the new angular speed of the merry-go-round?
Q0

A1 13.6 rev/min
A2 26.6 rev/min
A3 19.0 rev/min
A4 11.2 rev/min
A5 9.51 rev/min
Q0

Q30Q0 A wheel of radius 0.5 m rolls without slipping on a
12 Q0 horizontal surface as shown in Fig 5. Starting from rest, the
Q0 wheel moves with constant angular acceleration of 6.0 rad/s^2 .
Q0 The distance traveled by the center of the wheel from $t=0$
Q0 to $t=3.0$ s is:
Q0

A1 13.5 m
A2 18.1 m
A3 27.4 m
A4 0 m
A5 9.8 m