

Second major exam Term 992

- Q1 A 5.0 kg object starts from rest at point A, and slides 4.0 m down an inclined plane to point B (see Fig 1). The coefficient of friction is 0.2. Calculate the speed of the object at point B.
- A1 5.9 m/s
A2 66 m/s
A3 31 m/s
A4 2.7 m/s
A5 0 m/s
- Q2 A 2.0 kg object moves in a straight line with an initial speed of 4.0 m/s. It accelerates uniformly to a final speed of 7.0 m/s in 15 seconds. Calculate the average power delivered to the object.
- A1 2.2 W
A2 1.0 W
A3 11 W
A4 33 W
A5 5.5 W
- Q3 A body moving along the x axis is acted upon by a force (F_x) that varies with x as shown in Fig 2. Find the work done by this force on the object as it moves from $x=0.0$ m to $x=8.0$ m.
- A1 -34 J
A2 -2.0 J
A3 -18 J
A4 -10 J
A5 +18 J
- Q4 Under the action of a conservative force, 96 J of work are required to move an object from point A to point C, 130 J of work to move the object from point B to point D, and 59 J of work to move the object from point B to point C (see Fig 3). How much work is required to move the object from point A to point D?
- A1 178 J
A2 133 J
A3 96 J
A4 167 J
A5 286 J
- Q5 A pendulum of length 1.2 m and mass M is released from rest from point A where it makes an angle of 30 degrees with the vertical (see Fig 4). If the kinetic energy of the mass is 36 J at the bottom of its path (B), calculate the work done by the tension (T) in the string from point A to point B.
- A1 0 J
A2 36 J
A3 18 J
A4 48 J
A5 0.5 J
- Q6 A 2.5 kg hangs at rest from the free end of a vertical spring attached by one end to the ceiling. What is the change in elastic potential energy of the spring when the mass is lifted straight up until the spring reaches its unstretched position? ($k=240$ N/m)
- A1 -1.25 J
A2 2.50 J
A3 -4.60 J
A4 1.80 J
A5 -3.90 J
- Q7 Which of the following quantities CANNOT be used as a unit of potential energy?

- A1 $\text{kg}\cdot\text{m/s}^2$
- A2 watt*second
- A3 Joule
- A4 $\text{kg}\cdot\text{m}^2/\text{s}^2$
- A5 $\text{N}\cdot\text{m}$

Q8 A 0.20 kg ball is released from rest and falls 1.5 m to the floor. It rebounds to a maximum height of 1.0 m. Neglecting air resistance, find the impulse exerted by the floor on the ball.

- A1 1.97 N*s, vertically upward
- A2 2.49 N*s, vertically downward
- A3 2.49 N*s, vertically upward
- A4 0.85 N*s, vertically upward
- A5 0.85 N*s, vertically downward

Q9 An object at rest explodes into three pieces A, B and C. After the explosion, A has a mass of 2.0 kg and velocity $(3.0\hat{i})$ m/s, B has a mass of 3.0 kg and velocity $(-1.0\hat{j})$ m/s, and C has a mass of 1.0 kg and velocity v . Find the velocity v .

- A1 $(-6\hat{i} + 3\hat{j})$ m/s
- A2 $(3\hat{i} + 6\hat{j})$ m/s
- A3 $(6\hat{i} - 3\hat{j})$ m/s
- A4 $(6\hat{i} + 3\hat{j})$ m/s
- A5 $(3\hat{i} - 6\hat{j})$ m/s

Q10 Two objects, A and B, have the same momentum. B has more kinetic energy than A. Which of the following statements is CORRECT?

- A1 B is moving faster than A.
- A2 B weighs more than A.
- A3 B weighs the same as A.
- A4 B is moving slower than A.
- A5 B has a larger momentum than A.

Q11 A 3.0 kg object (A), moving at 8.0 m/s in the positive x direction, makes a head-on elastic collision with an object B, of mass M , initially at rest. After the collision, object B has a velocity of 6.0 m/s in the positive x direction. What is the value of M ?

- A1 5.0 kg
- A2 7.5 kg
- A3 6.0 kg
- A4 4.2 kg
- A5 8.0 kg

Q12 Which of the following statements is WRONG?

- A1 The torque acting on a particle is proportional to its angular speed.
- A2 Torque is defined only when a reference axis is specified.
- A3 The net work done by external forces in rotating a symmetric object about a fixed axis equals to the change in its rotational kinetic energy.
- A4 For rotation about a fixed axis, every particle of the rigid body has the same angular velocity.
- A5 For rotation about a fixed axis, every particle of the rigid body has the same angular acceleration.

Q13 Two masses $m_1=2.0$ kg and $m_2=4.0$ kg are connected to each other by a light cord that passes over a pulley of radius 3.0 cm and having a moment of inertia $0.045 \text{ kg}\cdot\text{m}^2$ about its axis of rotation. The cord does not slip on the pulley. At any instant after the masses start moving (see Fig 5), which of the following statements is CORRECT:

- A1 The pulley has the greatest kinetic energy.
- A2 Mass m_1 has the greatest kinetic energy.
- A3 Mass m_2 has the greatest kinetic energy.
- A4 The total kinetic energy of the two masses is larger than that of the pulley.
- A5 The kinetic energy of the two masses is the same as that of the pulley.

Q14 A wheel has a moment of inertia $12 \text{ kg}\cdot\text{m}^2$ about its axis of rotation. As it turns through 5.0 rev, its angular velocity increases from 5.0 rad/s to 6.0 rad/s. If the net torque about the axis of rotation is constant, its value is:

- A1 2.1 N·m
- A2 0.016 N·m
- A3 0.57 N·m
- A4 0.18 N·m
- A5 3.6 N·m

Q15 A disk has a moment of inertia $6.0 \text{ kg}\cdot\text{m}^2$ about a fixed axis of rotation. It has a constant angular acceleration of 2.0 rad/s^2 . If it starts from rest, the work done during the first 5.0 s by the net torque on it is:

- A1 300 J
- A2 0 J
- A3 30 J
- A4 60 J
- A5 600 J

Q16 The position vector of a particle of mass 4.0 kg is given as a function of time (t) by $\mathbf{r}(t) = (2.0 \mathbf{i} + 7t \mathbf{j} + 3 \mathbf{k}) \text{ m}$. Find the angular momentum of the particle about the origin.

- A1 $(-84 \mathbf{i} + 56 \mathbf{k}) \text{ kg}\cdot\text{m}^2/\text{s}$
- A2 $(8 \mathbf{i} + 12 \mathbf{k}) \text{ kg}\cdot\text{m}^2/\text{s}$
- A3 $(27t \mathbf{j}) \text{ kg}\cdot\text{m}^2/\text{s}$
- A4 $(28 \mathbf{j}) \text{ kg}\cdot\text{m}^2/\text{s}$
- A5 $(8 \mathbf{i} + 28t \mathbf{j} + 12 \mathbf{k}) \text{ kg}\cdot\text{m}^2/\text{s}$

Q17 A point mass M, at the end of a string, moves in a circle on a horizontal frictionless table as shown in Fig 6. As the string is slowly pulled through a small hole (O) in the table:

- A1 the angular momentum of M about O remains constant
- A2 the angular momentum of M about O decreases
- A3 the kinetic energy of M remains constant
- A4 the kinetic energy of M decreases
- A5 none of the other answers

Q18 Two objects of uniform density, a solid disk and a solid hoop, have the same mass and radius. They are placed at the bottom of an incline. They are given the same initial speed up the incline and roll without slipping. Which object travels a larger distance along the incline? [$I_{\text{cm}}(\text{disk}) = (M \cdot R^2)/2$ & $I_{\text{cm}}(\text{hoop}) = M \cdot R^2$]

- A1 The hoop.
- A2 The disk.
- A3 Both.
- A4 Depends on the initial speed.
- A5 Depends on the angle of the incline with the horizontal.

Q19 A cylindrical copper wire 1.0 m long has a cross-sectional diameter of 2.0 mm. Under what tension does it stretch by 1.0 cm? (Young's modulus of copper is $Y = 1.1 \cdot 10^{11} \text{ N/m}^2$)

- A1 3456 N
- A2 2163 N
- A3 6911 N
- A4 5420 N
- A5 0 N

Q20 A 1200 N uniform beam is supported by a cable as in Fig 7. The beam is pivoted at the bottom point O. Find the tension in the cable.

- A1 338 N
- A2 1465 N
- A3 725 N
- A4 1200 N
- A5 125 N

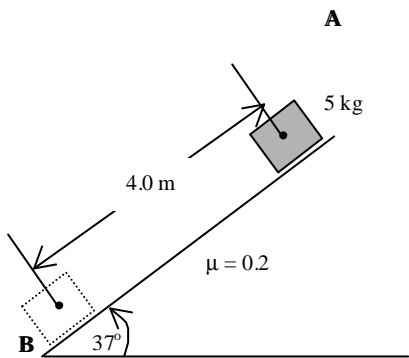

Figure 1

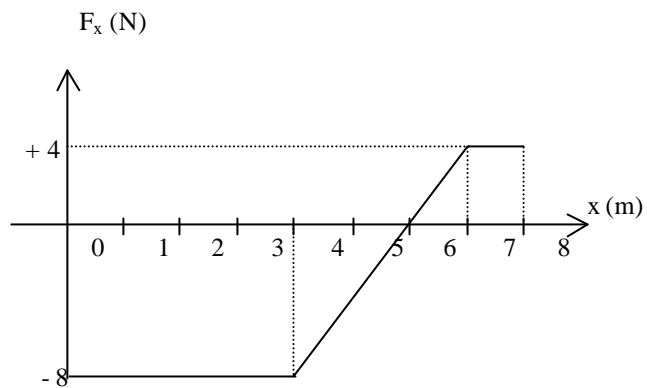

Figure 2

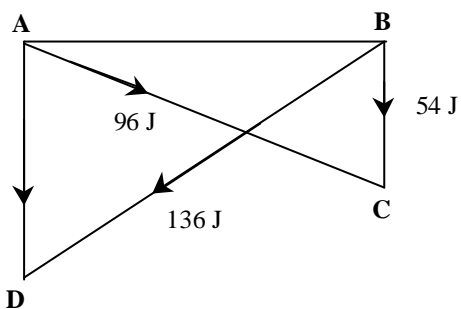

Figure 3

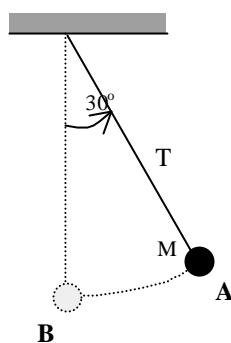

Figure 4

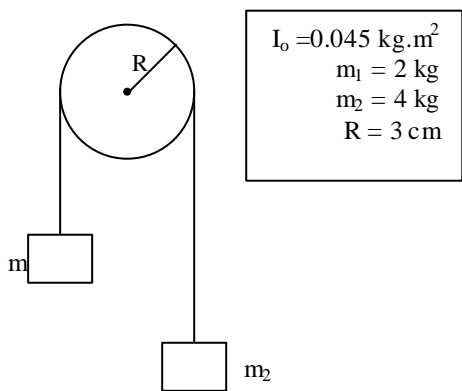

Figure 5

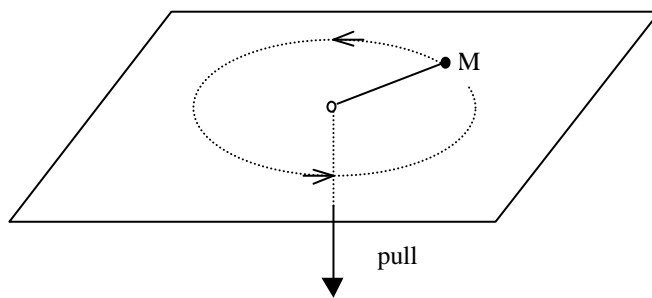

Figure 6

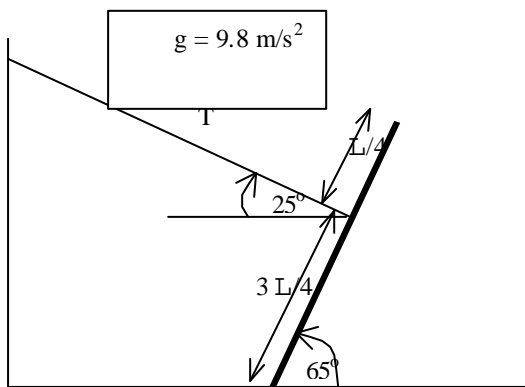

Figure 7