

Q1.

**Figure 1** shows four situations in which a central proton (P) is surrounded by protons or electrons fixed in place along a half-circle. The angles  $\theta = \phi = 30^\circ$ . What is the direction of the net force on the central proton P due to the other particles?

Fig#

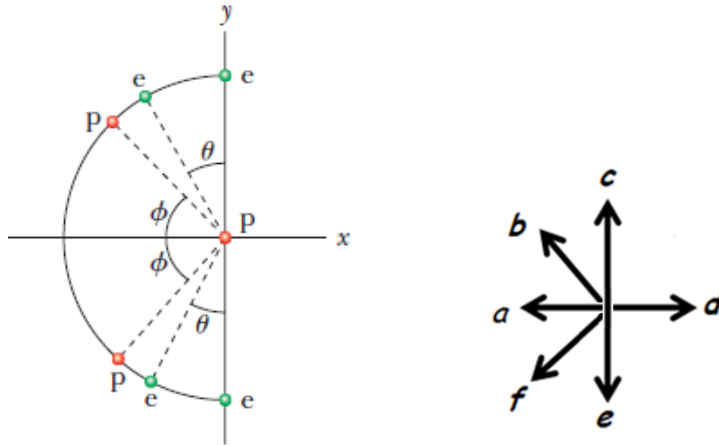

- A) **d**
- B) **a**
- C) **b**
- D) **f**
- E) **c**

Q2.

**Figure 2** shows three identical conducting spheres that are well separated from one another. Sphere W (with an initial charge of zero) is touched to sphere A and then they are separated. Next, sphere W is touched to sphere B (with an initial charge of  $-14e$ ) and then they are separated. The final charge on sphere W is  $+14e$ . What was the initial charge on sphere A?

Fig#

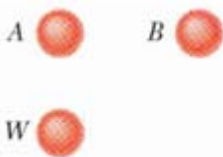

- A)  $+84e$
- B)  $-84e$
- C)  $+64e$
- D)  $-64e$
- E)  $+16e$

Q3.

**Figure 3** shows an arrangement of three charged particles, with angle  $\theta = 30.0^\circ$  and distance  $d = 2.00$  cm. Particle 1 has charge  $q_1 = +12.0 \times 10^{-6}$  C while particles 2 and 3 have charges  $q_2 = q_3 = -2.00 \times 10^{-6}$  C. What is distance  $D$  between the origin and particle 1 if the net electrical field at point P due to the three particles is zero?

Fig#

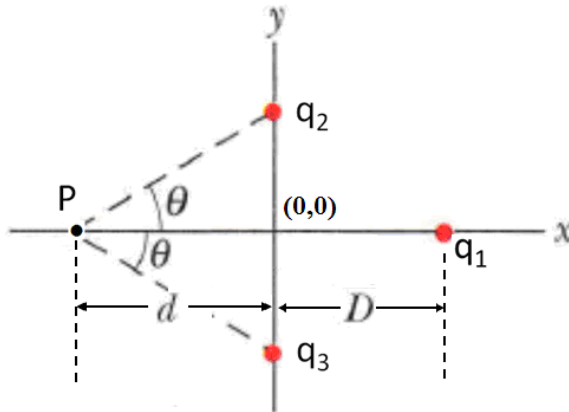

- A) 2.30 cm
- B) 1.30 cm
- C) 7.20 cm
- D) 4.45 cm
- E) 5.23 cm

Q4.

A particle (mass = 5.0 g, charge = 40 mC) moves in a region of space where the electric field is uniform and is given by  $E_x = 2.5$  N/C. If the velocity of the particle at  $t = 0$  is given by  $v_x = 50$  m/s, what is the speed of the particle at  $t = 2.0$  s?

- A) 90 m/s
- B) 72 m/s
- C) 81 m/s
- D) 42 m/s
- E) 25 m/s

Q5.

An electric dipole with dipole moment  $\vec{p} = (3.72\hat{i} + 4.96\hat{j}) \times 10^{-30}$  C.m is in an electric field:  $\vec{E} = (4000 \text{ N/C})\hat{i}$ . If an external agent turns the dipole until its electric dipole moment is:  $\vec{p} = (-4.96\hat{i} + 3.72\hat{j}) \times 10^{-30}$  C.m, how much work is done by the external agent?

- A)  $3.47 \times 10^{-26}$  J
- B)  $4.73 \times 10^{-26}$  J
- C)  $1.47 \times 10^{-26}$  J
- D)  $2.47 \times 10^{-25}$  J
- E)  $7.47 \times 10^{-27}$  J

Q6.

A  $5.14 \mu\text{C}$  point charge is at the center of a cube with sides of length  $0.25 \text{ m}$ . What is the electric flux through one of the faces of the cube?

- A)  $9.68 \times 10^4 \text{ N}\cdot\text{m}^2/\text{C}$
- B)  $1.81 \times 10^5 \text{ N}\cdot\text{m}^2/\text{C}$
- C)  $3.68 \times 10^4 \text{ N}\cdot\text{m}^2/\text{C}$
- D)  $4.68 \times 10^5 \text{ N}\cdot\text{m}^2/\text{C}$
- E)  $5.35 \times 10^3 \text{ N}\cdot\text{m}^2/\text{C}$

Q7.

Two thin nonconducting sheets of charges A and B, as shown in **Figure 4**, are parallel and vertical. The sheets have surface charge densities of  $\sigma_A = 3.8 \times 10^{-9} \text{ C/m}^2$  and  $\sigma_B = -1.9 \times 10^{-9} \text{ C/m}^2$  respectively. Find the ratio ( $E_2/E_1$ ) of the magnitude of the electric field in region 2 to that in region 1.

Fig#

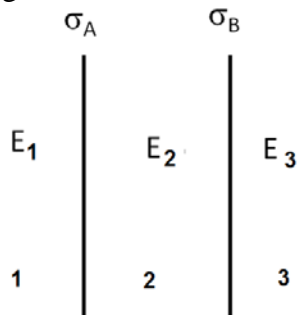

- A) 3.0
- B) 2.0
- C) 4.0
- D) 1.0
- E) 5.0

Q8.

Short sections of two very long parallel lines of charge, separated by  $L = 8.0 \text{ cm}$ , as shown in **Figure 5**, are fixed in place. The uniform linear charge densities of the wires are  $5.0 \mu\text{C/m}$  for line 1 and  $-1.0 \mu\text{C/m}$  for line 2, respectively. Where along the  $x$  axis, is the net electric field due to the two lines zero?

Fig#

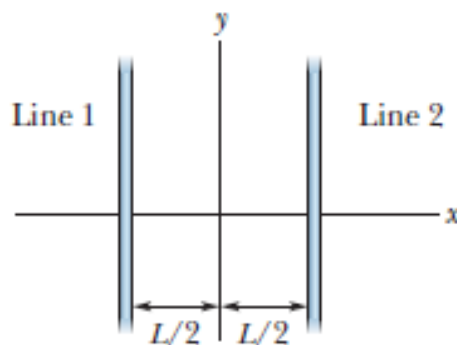

- A)  $+6.0 \text{ cm}$
- B)  $-6.0 \text{ cm}$
- C)  $+7.0 \text{ cm}$
- D)  $-5.0 \text{ cm}$
- E)  $+5.0 \text{ cm}$

Q9.

A non-conducting sphere of radius  $R = 7.0$  cm carries a charge  $Q = 4.0 \times 10^{-3}$  C distributed uniformly throughout its volume. At what distance, measured from the center of the sphere does the electric field reach a value equal to half its maximum value?

- A) 3.5 cm and 9.9 cm
- B) 2.5 cm and 7.9 cm
- C) 4.9 cm and 8.8 cm
- D) 3.5 cm and 8.1 cm
- E) 5.5 cm and 9.0 cm

Q10.

Two points A and B are located in a region of uniform electric field, as shown in **Figure 6**. If potential difference between points A and B,  $V_A - V_B = 90$  V, calculate the magnitude of electric field in the region.

Fig#

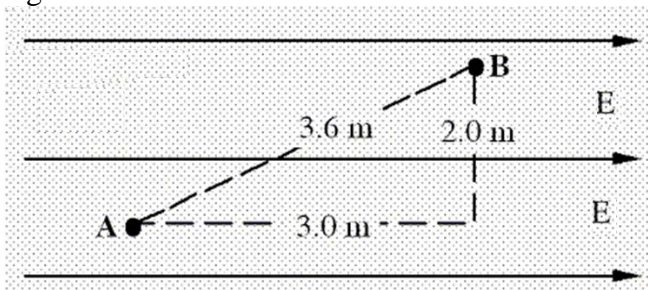

- A) 30 V/m
- B) 5.0 V/m
- C) 45 V/m
- D) 7.7 V/m
- E) 22 V/m

Q11.

Two charges  $Q_A = +q$  and  $Q_B = -5q$  are located on the x-axis at  $x = 0$  and  $x = d$ , respectively. Where on the positive x-axis is the electric potential equal to zero?

- A)  $x = d/6$
- B)  $x = 3d/4$
- C)  $x = d/3$
- D)  $x = 2d/3$
- E)  $x = d/2$

Q12.

Two identical particles, each with a mass of  $4.5 \times 10^{-6}$  kg and a charge of 30 nC, are moving toward each other along a straight line. The speed of each particle is 4.0 m/s at an instant when the distance between them is 25 cm. Find the closet distance they can get to each other?

- A) 7.8 cm
- B) 12 cm
- C) 9.8 cm
- D) 15 cm
- E) 5.5 cm

---

Q13.

An isolated system consists of two conducting spheres A and B. Sphere A has five times the radius of sphere B. Initially, the spheres are given equal amounts of positive charge and are isolated from each other. The two spheres are then connected by a thin conducting wire. Determine the ratio of the charge on sphere A to that on sphere B,  $q_A/q_B$ , after the spheres are connected by the wire. (Note: The potential is zero at infinity.)

- A) 5
- B) 1/5
- C) 1
- D) 25
- E) 1/25

---

Q14.

A parallel plate capacitor, with a capacitance of  $2.0 \times 10^{-6}$  F, is connected across a 25 V battery. If, with the battery still connected, you pull the plates apart until their separation is now twice of what it originally was, then the magnitude of the charge on each plate is:

- A) 25  $\mu$ C
  - B) 33  $\mu$ C
  - C) 19  $\mu$ C
  - D) 45  $\mu$ C
  - E) 11  $\mu$ C
-

Q15.

Four capacitors with capacitances  $C_1=15\ \mu\text{F}$ ,  $C_2=C_3=20\ \mu\text{F}$  and  $C_4=10\ \mu\text{F}$  are connected to a  $2.0\times 10^2\ \text{V}$  battery as shown in **Figure 7**. How much potential energy is stored in capacitor  $C_4$ ?

Fig#

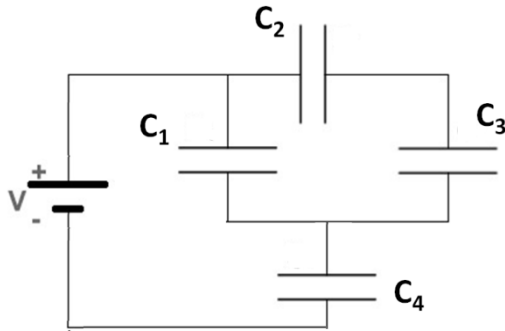

- A) 0.10 J
- B) 1.2 J
- C) 1.4 J
- D) 0.030 J
- E) 2.1 J

Q16.

The plates of a parallel plate capacitor each has an area of  $0.400\ \text{m}^2$  and are separated by a distance of  $0.0200\ \text{m}$ . They are charged until the potential difference between the plates is  $3000\ \text{V}$ . The capacitor is then disconnected from the battery. Suppose that a dielectric slab is inserted to completely fill the space between the plates and the potential difference between the plates drops to  $1000\ \text{V}$ . What is the capacitance of the system after the slab is inserted?

- A)  $5.31 \times 10^{-10}\ \text{F}$
- B)  $2.77 \times 10^{-10}\ \text{F}$
- C)  $1.84 \times 10^{-10}\ \text{F}$
- D)  $6.25 \times 10^{-10}\ \text{F}$
- E)  $6.85 \times 10^{-9}\ \text{F}$

Q17.

When a parallel-plate capacitor of capacitance  $C$  is connected to a power supply of voltage  $V$ , the energy density in the capacitor is  $u$ . If the voltage of the power supply is doubled, which of the following changes would keep the energy density equal to its previous value  $u$ ?

- A) doubling the spacing between the plates.
- B) doubling the area of the plates.
- C) reducing the area of the plates by half.
- D) reducing the spacing between the plates by half.
- E) The energy density is unaffected by a change in the voltage.

Q18.

A small bulb is rated at 7.50 W when operated at 125 V. The filament of the bulb has a temperature coefficient of resistivity  $\alpha = 4.50 \times 10^{-3} / ^\circ\text{C}$ . When the filament is hot and glowing, its temperature is 140  $^\circ\text{C}$ . What is the resistance of the filament (in ohms) at 20  $^\circ\text{C}$ ? (Ignore change in physical dimension of the filament)

- A)  $1.35 \times 10^3$
- B)  $1.86 \times 10^2$
- C)  $2.73 \times 10^3$
- D)  $1.99 \times 10^2$
- E)  $1.67 \times 10^4$

---

Q19.

A wire carries a 6.0 mA current. How many electrons pass through a given point in the wire in a minute?

- A)  $2.3 \times 10^{18}$
- B)  $6.3 \times 10^{14}$
- C)  $3.3 \times 10^{16}$
- D)  $6.3 \times 10^{16}$
- E)  $5.4 \times 10^{15}$

---

Q20.

Two cylindrical resistors  $R_1$  and  $R_2$  are made from the same material and have the same length but different radii  $r_1$  and  $r_2$ , respectively. When connected across the same battery,  $R_1$  dissipates twice as much power as  $R_2$ . Determine ratio of their radii  $r_1/r_2$ .

- A) 1.41
  - B) 2.42
  - C) 1.92
  - D) 1.00
  - E) 3.20
-