



## THE USE OF AN OPEN CYCLE ABSORPTION SYSTEM IN AUTOMOBILES AS AN ALTERNATIVE TO CFCs

N. Al-Aqeeli<sup>1</sup>, P. Gandhidasan<sup>2</sup>

1: Graduate Assistant, Mechanical Engineering Department, KFUPM, Dhahran, Saudi Arabia.

2: Associate Professor, Mechanical Engineering Department, KFUPM, Dhahran, Saudi Arabia.

E-mail: naqeeli@kfupm.edu.sa

### ABSTRACT

Increased awareness of the impact of chlorofluorocarbons (CFCs) on the global environment has become the impetus in searching for alternative refrigerants and cooling methods for automotive air conditioning. Automotive air conditioning is one industry that heavily uses CFC compounds, and the leakage of CFCs from such air conditioners is substantial compared to that from stationary air conditioners. Therefore, the use of non-CFC air conditioners in automobiles is apparently becoming very important. The main objective of this paper is to study the feasibility and design of an air conditioning system for automobiles using the Open Cycle Absorption System, with LiBr-H<sub>2</sub>O as the working fluid. Also, some suggestions are given to minimize the power loss like making use of the exhaust gas to pre-heat the weak desiccant. Evaluating the COP, of the designed air conditioning system for buses is the main scope, and it is found that the COP of the system is increasing with the increase in regeneration temperature at fixed evaporator and absorber temperatures. The system components are plotted in a schematic and flow chart as well as psychrometric chart showing the complete process of conditioning and dehumidifying air.

**Keywords:** open cycle, absorption system, desiccant, dehumidification, LiBr-H<sub>2</sub>O, regeneration.

(CFC)

## **1. INTRODUCTION**

The current automobile air conditioning systems are using CFC as the working fluid, which has many detrimental effects on the environment; like breaking the Ozone layer. So, the need of alternative refrigerants or cooling methods to replace these systems that utilize CFCs comes into the picture. One technique, which is using the desiccants as the working fluid promises to be a suitable solution to the encountered problem. Desiccants are chemicals that have the ability of absorbing moisture from a mixture of air and water when it comes in contact with them [Everetts, 1957]. The desiccants have advantages over the CFC in that desiccants do not affect the environment. This paper deals with the design of an Open Cycle Absorption System, which uses the desiccant in order to cool the air. This air conditioning system is designed for the use inside buses and it has many applications in the air conditioning industry. The Open Cycle Absorption system that uses the desiccant was used because it is more economical than the current systems.

There are two types of buses, differing in their uses and the cooling load required to comfort the passengers, Urban and Interurban buses. Urban bus heating and cooling loads are greater than those of the interurban bus because urban bus stops frequently and may open both front and rear doors to take on or discharge passengers [ASHRAE, 1995]. Moreover, a city bus may seat up to 50 people and carry a crush load of standees. The fresh air load is greater because of constant door opening and infiltration around doors. It is stated in the literature that the cooling capacity required for the typical 50-seat urban bus is from 6 to 10 tons of refrigeration [ASHRAE, 1995]. Also, bus air conditioning design must consider highly variable passenger and climatic loads. It is usually not practical to design for a specific climate, so the design should consider all likely climates.

## **2. LITERATURE REVIEW**

Since the introduction of automotive air conditioning, CFC-12 has been the refrigerant of choice due to its unique combination of properties. These include low toxicity, nonflammability, good stability and materials compatibility, oil solubility, and good thermodynamics properties. Recent scientific evidence has implicated CFC-12, along with other fully halogenated chlorofluorocarbons (CFCs), in the possible depletion of the Ozone layer in the stratosphere. Changing this refrigerant and finding alternative one is not an easy task, since a great percentage of today's cars are equipped with systems consuming CFC-12 heavily.

HFC-134a shows some acceptable properties and possibilities of substituting the old refrigerant without changing the old system. HFC-134a is an environmentally acceptable refrigerant, which being developed as a replacement for the suspected Ozone-depleting CFC-12 [Bateman,1989]. Unfortunately, the transport and thermodynamic properties of the

new working fluid require a special attention because it needs new lubricants and sometimes changing the whole equipment. However, with the development of a new refrigerant the problem is partially solved, because still there is the high fuel consumption with this new refrigerant. So, changing the whole system and finding a new system that satisfies all the requirements is the only solution.

## **2.1 Vapor Absorption Cooling System**

Vapor absorption Cooling System is expected to solve the problems faced in the vapor compression system that uses CFCs because it is totally CFC-free, simpler and does not require the operation of a compressor which consumes a significant amount of power. It does not use CFCs, but it is restricted in use to arid climates. This limitation can be eliminated by dehumidifying the supply air using desiccants. Currently, integrating a vapor-compression system with a liquid desiccant dehumidifier will result in about 35% energy saving, and calculations show more savings when coupling liquid desiccant dehumidifier to a vapor-absorption system [Ahmed et al, 1997].

Vapor absorption cooling system can be classified into Open Cycle and Closed Cycle in which there are major differences between them in terms of design and function. The Open Cycle system is different from the Closed Cycle system in that the former does not need a separate condenser. Cooling takes place by evaporating refrigerant in the evaporator, which can be provided from an external source, rather than obtaining refrigerant from the condenser. Then the desiccants absorb vapor in the absorber and become weak since the vapor pressure of a desiccant is directly proportional to its temperature and inversely proportional to its concentration. The Open Cycle regenerates the weak desiccant by losing the refrigerant to the earth's atmosphere by the mean of regeneration. So, the condenser has no use in the open cycle, and that's why it is eliminated. [Collier, 1979]

## **2.2 Desiccant Cooling**

Desiccants are those substances that have the ability of holding water vapor, and have low vapor pressures at the temperatures encountered today in commercial and industrial air conditioning work [Everetts, 1957]. These desiccants can be either solid like silica gel, zeolites, and synthetic polymers or liquid, like calcium chloride, lithium chloride, glycol and lithium bromide, and when a solid desiccant is utilized the system is called Adsorption, but when liquid desiccant is used it is an Absorption system. Solid desiccants are preferred because they are low-cost materials, simpler in design and, as stated in the literature, adsorption systems have higher COP than absorption ones [Mei et al, 1992]. Despite these valuable advantages, some problems were encountered in using solid desiccants, like the impossible preheating and precooling of the desiccants, the regeneration temperatures are higher than those of liquid desiccants and difficult in mobility. However, these disadvantages

of the solid desiccants turn to be useful advantages of the liquid ones since chemicals can circulate freely into the system.

### **2.3 The Working Fluid**

In order to account for safety and efficiency the desiccant should be non-corrosive, odorless, stable (not breaking down over the range of use), having low viscosity and good heat transfer characteristics, non-toxic, non-flammable, widely available and economical to manufacture [Everetts, 1957]. Presently, two types of absorption air conditioning systems are widely marketed: one of them is the Lithium Bromide-water (LiBr-H<sub>2</sub>O) system and the other one is the Ammonia-water (NH<sub>3</sub>-H<sub>2</sub>O) system. In the (LiBr-H<sub>2</sub>O) pair, water is the refrigerant while lithium bromide acts like absorbent, but in the (NH<sub>3</sub>-H<sub>2</sub>O) pair water is the absorbent. Of the two common absorption air conditioning systems, the LiBr-H<sub>2</sub>O is simpler, since a rectifying column is not needed (because only water vapor is driven off in the generator) [Kuehn et al, 1998]. In the NH<sub>3</sub>-H<sub>2</sub>O system a rectifying column assures that no water vapor, mixed with NH<sub>3</sub>, enters the evaporator where it could freeze. In addition, the NH<sub>3</sub>-H<sub>2</sub>O system requires higher generator temperatures 120-150°C (250-300°F) than a flat-plate solar collector, for example, can provide. On the other hand the LiBr-H<sub>2</sub>O system operates satisfactorily at a generator temperature of 88-93°C (190-200°F), which is achievable by, even, a flat-plate solar collector. Also, the LiBr-H<sub>2</sub>O system has a higher COP than the NH<sub>3</sub>-H<sub>2</sub>O system [Kuehn et al, 1998]. The only disadvantage of LiBr-H<sub>2</sub>O systems is that evaporator cannot operate at temperatures much below 4.4°C (40°F) since the refrigerant is water vapor.

### **3. COOLING LOAD CALCULATIONS**

One of the critical issues or tasks in designing any system, especially bus air conditioning system, is to calculate the load that should be removed from the desired place. There are so many considerations that should be taken into account in calculating the load. Heat sources, which will impose loads on the cooling equipment, may be broken down as follows:

- Heat due to interior temperature build up.
- Radiation heat through the glass.
- Conductive heat through the body.
- Convective heat due to body leaks.
- Convective heat due to fresh air intake.
- Passengers' heat.
- Instruments heat.

Previous studies and experiments were performed by researchers, and they gave results to describe the effect of each heat source inside the automobile [Ruth, 1975]. For the sake of

this paper those information could be very helpful in order to calculate the amount of heat that should be removed from the cabinet of the bus. The values present in the literature can be modified to become valid for the bus system by suitably multiplying each factor. Different designers may take different assumptions and follow different aspects, but the best design is the one that takes all factors, which affect the load calculations into account. To validate the car information to the bus the following multiplication is done:

- increasing solar radiation by 6 times.
- increasing conduction through the body factor by 10.
- modifying fresh air intake by 3 times greater.
- Multiplying latent heat, for each passenger, by the number of passengers.
- increasing instrumental effect by 7 factors.
- Considering a bus with 40 passengers including the driver.

Table (1) shows the modified data for a bus having 40-passengers. From that table the Cooling Load = 78320 Btu/hr

Cooling Load = 6.53 tons (23 kW)

For designing the system the calculated value can be approximated to 7 tons. This value falls into the range mentioned previously in the literature [ASHRAE, 1995].

## **4. THE PROPOSED AIR-CONDITIONING CYCLE**

### **4.1 Cycle Description**

The proposed cycle shown in figure (1) consists of a liquid desiccant dehumidifier integrated with an absorption cooling system, and uses LiBr as the liquid desiccant for absorption and dehumidification processes, and water as refrigerant. Following figures (2 & 3) show a flow chart of the proposed system and the processes in the psychometric chart, respectively. In this design the use of a source of regeneration is crucial to concentrate the weak desiccant by releasing refrigerant to the atmosphere. In this cycle an external source of refrigerant (water) must always be available (state 1) in order to provide cooling by evaporating refrigerant in the evaporator rather than obtaining it from a condenser. The amount of water that must be supplied to the system should be equal to the amount of refrigerant released to the environment via the regenerator.

The weak desiccant is then pumped from the absorber (state 4) to the regenerator through the regenerative heat exchanger (HE) (states 6-7). In the regenerator the desiccant solution is heated to release refrigerant from the solution and maintain a strong desiccant again. Attached to the regenerator is the strong desiccant storage tank to store the concentrated solution and

provide it whenever needed or in the case of loss of regeneration source. Then, the strong solution is delivered to the absorber via (HE) (states 8-9), to make use of the heat gained from the regenerator to pre-heat the incoming weak solution. When the incoming refrigerant evaporates in the evaporator (state 2), by absorbing heat from the place to be cooled, the strong desiccant absorbs water vapor from it. The cooling tower is used to remove the heat of absorption from the refrigerant-absorbent solution. Water is evaporated in the evaporator at reduced pressure with the energy supplied by the heat from the cooled place. At this stage it is necessary to mention the importance of having an evacuating pump to reach the desired pressure in the evaporator.

The evaporator-absorber assembly is evacuated to a certain pressure, which corresponds to a required saturation temperature at the evaporator. Water vapor is absorbed in the absorbent solution (strong desiccant) due to the high affinity between the two. The absorbent solution then becomes weak in the absorber and is pumped to the regenerator where it gets heated and becomes strong to complete the cycle. Part of the strong desiccant coming from the regenerator (state 11) is passed to the dehumidifier where the air to be conditioned is dehumidified. The idea of dehumidification is accomplished by having vapor pressure difference between the vapor in air and the liquid desiccant.

As the regenerated liquid desiccant is cooled and becomes stronger, its vapor pressure is less than the vapor pressure of the atmospheric air, therefore the vapor present in the air tends to escape into the liquid desiccant and accordingly makes it weak again. The weak desiccant from the dehumidifier (state 5) is then pumped back for regeneration along with the weak desiccant from the absorber and completes the cycle.

## 4.2 Cycle Analysis

### 4.2.1 Mass Balance

The total mass balance in the regenerator gives,

$$m_7 = m_{tr} + m_g \quad (1)$$

where  $m_{tr}$  is the total moisture (refrigerant and dehumidified moisture) and is given by,

$$m_{tr} = m_{ra} + m_{rd} \quad (2)$$

and  $m_{ra}$ : is the evaporated mass from evaporator to absorber

A packed bed dehumidifier is proposed for this system. The dehumidifier suggested is of 50cm diameter and the flux is 3 kg of air per second per  $m^2$ . The air will be dehumidified

from 0.02 to 0.014 kgH<sub>2</sub>O/kg air. With these specifications of the dehumidifier one can get the amount of moisture  $m_{rd}$  added to the coming fluid from the absorber.

LiBr mass balance yields,

$$m_7 X_7 = m_8 X_8 \quad (3)$$

Solving equations (1) & (3) gives,

$$\frac{m_8}{m_{tr}} = \frac{X_7}{(X_8 - X_7)} \quad (4)$$

This gives the ratio of total absorbent-refrigerant flow rate. It is assumed that exactly 50% of the concentrated solution from the regenerator is supplied to absorber and the remaining 50% to the dehumidifier. Since  $m_8=2m_{10}$  the value of  $m_8$  can be substituted in equation (1), and we have:

$$m_7 = 2m_{10} + m_{tr} \quad (5)$$

where  $m_7$  is the total mass of the solution reaching the regenerator and is given by,

$$m_7 = m_4 + m_5 \quad (6)$$

the expression for  $m_4$  (total mass flow rate from the absorber) is,

$$m_4 = m_{10} + m_{ra} \quad (7)$$

mass balance in the dehumidifier results in,

$$m_5 = m_{11} + m_{rd} \quad (8)$$

With 40°C and 2 kPa as the equilibrium conditions in the absorber, the weak LiBr solution leaves the absorber with a concentration of 55%. Using a regenerator with an outlet temperature of about 70°C, the equilibrium concentration at the regenerator conditions will be 61% and the strong solution will leave the regenerator with an enthalpy of 189 kJ/kg. Hence, the ratio of the absorbent  $m_4$  to refrigerant  $m_{tr}$  flow rate is 8.33, while the ratio of the refrigerant-absorbent flow rate  $m_3$  to the refrigerant flow rate  $m_{tr}$  is 9.33.

#### 4.2.2 Energy Balance

The evaporator capacity is given by,

$$Q_{ev} = m_2 (h_2 - h_1) \quad (9)$$

The amount of energy collected for the regeneration of the weak desiccant is given by,

$$Q_{gen} = m_{tr} h_t + m_8 h_8 - m_7 h_7 \quad (10)$$

Starting from the fact that the cooling load for this system  $Q_{ev}$  is 6.53 tons (approximately 23 kW), analyzing and giving the details of each state in the system is possible. Moreover, the cycle parameters are calculated at every state point of the cycle. Table (2) shows the values of mass flow rate, enthalpy and temperature at every state point.

Substituting values in the previous equations yields the following quantities per unit mass flow rate of vapor released:

$$Q_{gen} = 2424.9 \text{ kW}$$

$$Q_{ev} = 2421.1 \text{ kW}$$

The integrated vapor absorption and liquid desiccant system COP is estimated by,

$$COP = \frac{Q_{ev}}{Q_{gen}} = 0.9984.$$

The vapor absorption and liquid desiccant system would produce a cooling effect of 7 tons (at an evaporator temperature of 22°C) per unit mass flow rate of the refrigerant.

## 5. RESULTS AND DISCUSSION

From the results obtained earlier in this paper it is clear that the system is feasible to be designed with good reduction in the cost of operation and fuel consumption. The other advantage of this system is its safety, because it does not affect the global warming and the Ozone layer. To evaluate the design of this system theoretically, we shall study the COP variation by altering the regenerator temperature, and suggest some parameters of the system and how to position them. In the following discussion we will consider some cases and give the most appropriate way to deal with them in order to optimize the design:



### **5.1 COP Variation**

From the previous discussion regarding the COP value, it can be seen that this COP depends mainly on the evaporation and regeneration energies. So, changing the values of these two will produce a graph that covers the whole region of operation, since the calculated value of the COP is only for one condition. The values of the evaporator temperature ( $T_{ev}$ ) are limited by the dehumidifier presence and liquid desiccant properties. The range selected for the regeneration temperature ( $T_{gen}$ ) is from 65-85°C. The variation of COP is illustrated in figure (4), which shows that the COP value increases with increasing the regeneration temperature at fixed evaporator and absorber temperature. This indicates that higher regeneration temperatures are needed in order to allow the system to work efficiently.

### **5.2 Solar Regenerator**

In this part it is necessary to mention the need for a good source to regenerate the weak desiccant and make it strong. One way of doing that is to install a solar regenerator in the system because it does not consume power and in some hot areas it is really worth to use it. The most suitable kind of the solar regenerator is the partly closed-open one to allow the refrigerant to escape (evaporate) in the atmosphere. Having solar regenerator with high efficiency is crucial to assure evaporation of the refrigerant fluid and concentration of the absorbent. The most suitable place for the solar regenerator in our design is at the roof of the bus where the regenerator can receive the maximum sunshine.

Also, it is necessary to use some energy storage technique in order to operate the system at night where the solar energy is not available. We have two options in this matter, either installing the storage tank near the regenerator or installing it near the evaporator. For the first option, which is installing the storage tank near the regenerator, we shall keep the solar energy and provide it when necessary to evaporate the refrigerant and concentrate the absorbent. However, for the second option we make the other thing around we keep the chilled water in the storage tank near the evaporator and use it to cool the air. Among these two options the first one is better and we have so many alternatives to use in storing the solar energy near the regenerator (for instance, water storage or pebble bed (rock) storage) [Duffie and Beckman, 1991 ]. Another option is storing some concentrated desiccant to be used when there is no regeneration source.

### **5.3 No Dehumidifier Effect**

One question may be raised at this stage that if we didn't use a dehumidifier in this system what would happen? The answer to this question is that: without using a dehumidifier in this system all the heat should be taken out by the evaporator (latent & sensible loads). The evaporator temperature now should go down more in order to take all the heat from the space

to be cooled. Because for the system discussed in this paper it is assumed that the latent load (moisture) is taken by the dehumidifier and sensible load is taken by the evaporator (produce cooling).

Neglecting the dehumidifier from the system may result in adding more loads into the system to allow the evaporator to do the whole job. The evaporator temperature should go down up to 15 or 10°C and it is not possible to send the air to the cabinet with this temperature. In order to solve this problem we should install some partial-heating source. Adding a partial-heating source without consuming more energy can be achieved by making use of the exhaust gas in heating the air before sending it to the cabinet.

#### **5.4 System's Moving Parts**

The open cycle absorption cooling system can be operated by a small capacity vacuum pump [Duffie and Beckman, 1991]. This could be driven directly by the van engine through a separate gear system. Similarly, two small pumps, one to circulate the weak solution from the absorber to the regenerator and the other to circulate the water from the evaporator to the evaporative sprayer, could also be driven by the engine. These are the only three moving parts in the open cycle absorption system, which could need some maintenance.

### **6. RECOMMENDATIONS**

The system described previously can result in a reduction in cost and fuel consumption. Fuel consumption for running desiccant systems was about 70% less than CFC refrigeration systems. The following discussion summarizes some of the important considerations that will help in reducing the cooling load as well as the cost of operation:

- Using a solar regenerator will result in a great reduction in the load and cost of operation.
- Making benefit of the exhaust gas in heating the air that goes into the cabinet.
- Reducing the fresh air intake and sealing the bus body can result in a 30% saving in cooling requirements [Ruth, 1975].
- Tinting the glass can result in an 18% saving in cooling requirements [Ruth, 1975].
- By careful design with comfort cooling kept in mind the capacity of cooling systems in buses may be cut almost in half with corresponding savings in power and fuel.
- Appreciable load reduction can be realized by altering the slope of the front and rear windows.

## 7. CONCLUSIONS

Based on the preliminary calculations and feasibility study, the proposed open cycle absorption cooling system may eventually replace the existing systems. This study looked at the possibilities of using desiccant dehumidification as a pre-conditioner for a vapor absorption cooling system to be used in a vehicle like bus, making use of the solar radiation in regeneration and the waste heat from the engine for pre-heating.

The concept is found to be technically and economically feasible within the limitations imposed by engineering estimates. Full-scale prototypes must be fabricated and installed in buses and then tested in different climates for a sufficient amount of time to give a final judgement on the system. Only then can we answer very specifically questions regarding costs, operation, performance, maintenance, electric and fuel consumption and the reliability of desiccant cooling systems for buses.

## ACKNOWLEDGEMENT

The authors are grateful for the support provided by King Fahd University of Petroleum & Minerals (KFUPM).

## REFERENCES

1. Ahmed, C. S. K., Gandhidasan, P. and Al-Farayedhi, A. A., 1997, "Simulation of a Hybrid Liquid Desiccant Based Air-Conditioning System". *Applied Thermal Engineering*, 17 (2), pp. 125-34.
2. Bateman, D. J., 1989, "Replacement refrigerant for automotive air conditioners". *Automotive Engineering*, 97 (11), pp. 33-6.
3. "Bus Air Conditioning", 1995, *ASHRAE Applications Handbook*, pp. (8.7-8.9).
4. Collier, R. K., 1979, "The Analysis and Simulation of Open Cycle Absorption Refrigeration System". *Solar Energy*, 23, pp. 357-66.
5. Duffie, J. and Beckman, W., 1991, *Solar Engineering of Thermal Processes*. John Wiley & Sons, Inc., pp. 384-410.
6. Everetts, J. Jr., 1957, "Symposium on Dehumidification". *Heating, Piping & Air Conditioning. 63<sup>rd</sup> Annual meeting of ASHRAE*, pp. 152-67
7. Kaudinya, J.V., Kaushik, S.C. and Kaudinya, R., 1988, "The feasibility of air-conditioning by exhaust gas". *International Journal of Ambient Energy*, 9 (4), pp. 185-90.
8. Kuehn, T.H., Ramsey, J.W. and Threlkeld, J.L., 1998, *Thermal Environmental Engineering*. Prentice-Hall Inc., pp. 139-47.
9. Mei, V.C., Chem, F.C., and Kyle, D.M., 1992, "Alternative Non-CFC Mobile Air Conditioning". *Final Report, U.S. Department of Energy. ORNL/CON-335*, pp. 33
10. Rubin, E. S., 2001, *Introduction to Engineering and the Environment*. McGraw Hill Publisher, pp. 270-5
11. Ruth, D. W., 1975, "Simulation Modeling of Automobile Comfort Cooling Requirements". *ASHRAE Journal*, pp. 53-5.

**Nomenclature**

- $m_{tr}$  mass flow rate of refrigerant, (kg/s)
- $m_{rd}$  mass flow rate of vapor from dehumidifier, (kg/s)
- $m_4$  total mass flow rate from the absorber, (kg/s)
- $m_{ra}$  evaporated mass from evaporator to absorber, (kg/s)
- $m_{10}$  mass flow rate flowing from regenerator to absorber, (kg/s)
- $X_7$  concentration of weak solution, (kg absorbent per kg solution)
- $X_8$  concentration of strong solution, (kg absorbent per kg solution)
- $h_t$  enthalpy of refrigerant at average temperature of the regenerator, (kJ/kg)

Table (1): Breakdown of Heat Load for 40-Passengers bus.

Load (Heat Source)	Value (W)
Solar radiation	7860
Conduction through the body	5190
Fresh air intake	4749
Latent heat (Driver & 40 Passengers)	(176 & 40 (118))
Instrument	413
Total	23108

Table (2): Cycle Parameters

State Pts.	T (°C)	h (kJ/kg)	Mass flow rate (kg/s)
1	30	126	0.0095
2	22	2541	0.0095
3	40	122	0.0638
4	40	122	0.0638
5	44	143	0.0578
6	38	122	0.1216
7	60	159	0.1216
8	70	189	0.1086
9	60	181	0.1086
10	60	181	0.0543
11	60	181	0.0543

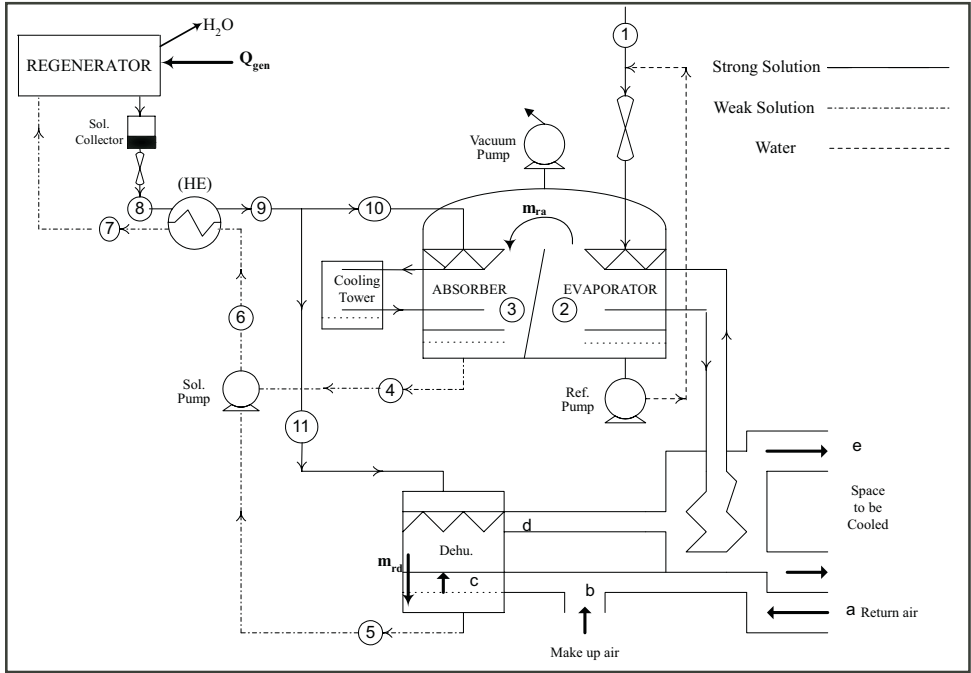

Figure (1): The proposed Cycle.

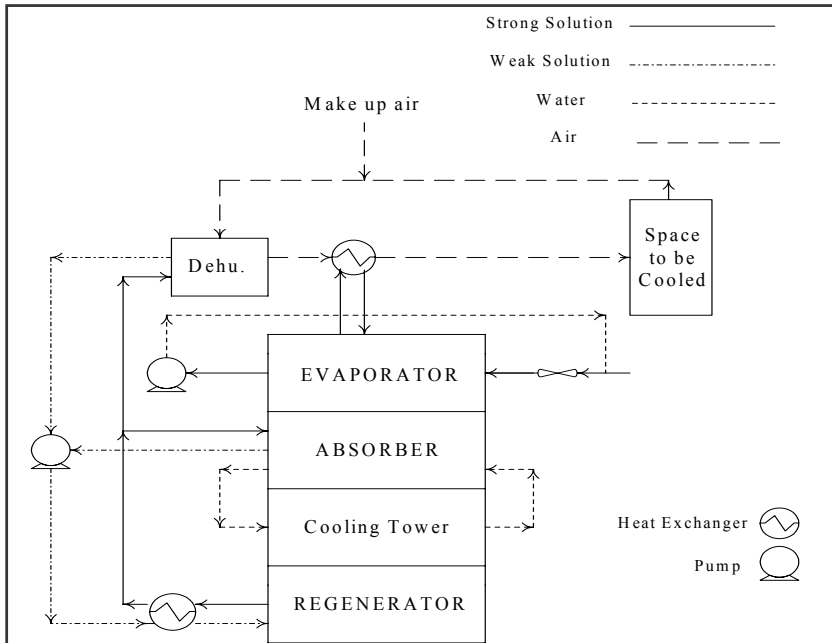

Figure (2): Flow Chart of the liquid desiccants and the refrigerant circulation.

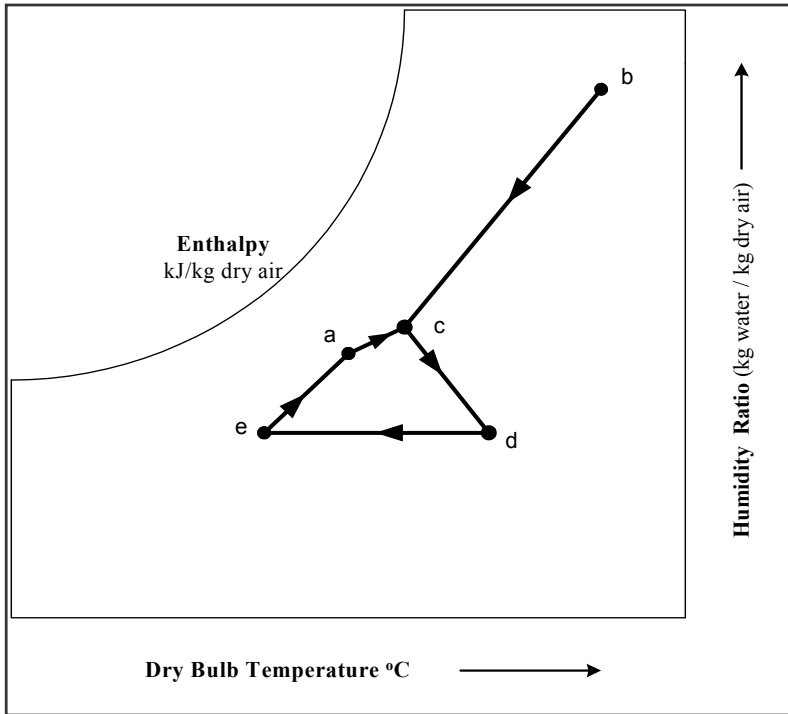

Figure (3): Processes in the psychrometric chart.

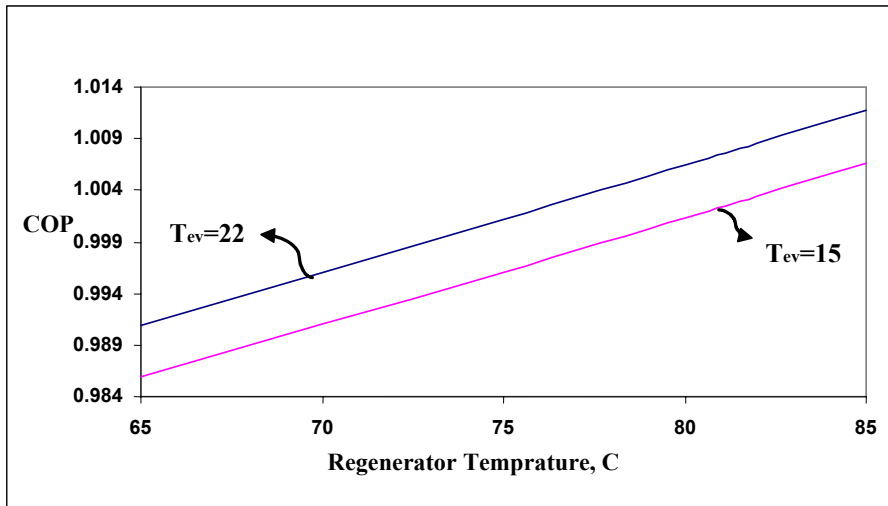

Figure (4): The variation of COP with the regenerator temperature.