

A New Approach to Interference Mitigation in Multirate DS/SS systems

F. Hendessi, A. Zali, A. Ghayoori
 Dept. of Electrical and Computer Engineering
 Isfahan University of Technology
 Isfahan, Iran
 hendessi@cc.iut.ac.ir

Abstract— Most of the modulated signals are known to have cyclostationary property in their probabilistic distribution. As it is shown, this cyclostationary property of the signal leads to the presence of redundancy in signal frequency spectrum. This redundancy can be utilized in the design of higher performance receivers with better-restored signal quality. In this paper, the use of cyclostationary property is examined for designing CDMA systems. It is shown that using spectral redundancy, which exists in CDMA signals, leads to higher performance receivers. One of these optimum receivers, which are based on the received signal's cyclostationary property, is FRESH-DFE. In this paper we compare two different filters, FRESH-DFE & conventional DFE in multiple access CDMA systems. A set of simulations was done in different situations and in all of them the FRESH-DFE showed better performance than conventional DFE.

Keywords-component; FRESH-DFE; CDMA; CA; CCA

I. INTRODUCTION

In spite of the cyclostationary property of the most communication modulated signals, the conventional methods of interference cancellation can not utilize this spectral redundancy. In the other words, the conventional receivers assume that the input signal has stationary property.

Spread spectrum signals have cyclostationary property and have a high spectral redundancy. The conventional time independent filters can not profit from this redundancy. So the time variant filters should be exploited to properly utilize the spectral redundancy of the signal.

The simulations showed that using cyclostationary property leads to performance amelioration and higher capacity of the CDMA systems.

In the case, which all the users have similar Bit Rate and the utilized codes repeat in every symbol period, the receiver, which used Cyclostationary property, becomes as same as conventional equalizer. In this paper we

II. CYCLOSTATIONARY CONCEPT

Many random processes arise from the repetition of a given procedure every T seconds and the periodic nature of such processes is apparent in their probabilistic descriptions.

A random process $x(t)$ is said to be cyclostationary if the joint cumulative distribution function of any set of samples is invariant with respect to the shifts of the region by integer multiples of some period T [6]. We say that $x(t)$ is wide-sense cyclostationary if the mean and autocovariance functions are invariant with respect to shifts in the time origin by integer multiples of T, that is, for every integer m,

$$\begin{aligned} m_x(t + mT) &= m_x(t) \\ R_x(t_1 + mT, t_2 + mT) &= R_x(t_1, t_2) \end{aligned} \quad (1)$$

Equation (1) can be re-expressed using the symmetric version of time-dependant autocorrelation (STDA) as follows [1]:

$$R_x(t + \tau/2 + T, t - \tau/2 + T) = R_x(t + \tau/2, t - \tau/2) \quad (2)$$

Since $R_x(t + \tau/2, t - \tau/2)$ is periodic in t with period T for each τ , it can be expressed by the Fourier series representation as:

$$R_x(t + \tau/2, t - \tau/2) = \sum R_x^\alpha(\tau) e^{j2\pi\alpha t} \quad (3)$$

where $\{R_x^\alpha(\tau)\}$ are the Fourier coefficients,

$$R_x^\alpha(\tau) = \frac{1}{T} \int_{-T/2}^{T/2} R_x(t + \tau/2, t - \tau/2) e^{-j2\pi\alpha t} dt \quad (4)$$

If a random process contains other cyclostationary processes with different periods $\{T_i : i = 1, \dots, M\}$ where M is the number of cyclostationary components, it is said to be almost cyclostationary with periods $\{T_i\}$ [1]. $R_x^\alpha(\tau)$ is referred to as the cyclic autocorrelation (CA) function, and α is called the cyclic frequency parameter [1]. Conjugate cyclic autocorrelation (CCA) function is defined as follows:

$$R_{xx}^\alpha(\tau) = \lim_{z \rightarrow \infty} \frac{1}{z} \int_{-z/2}^{z/2} E \left\{ x\left(t + \frac{\tau}{2}\right) x\left(t - \frac{\tau}{2}\right) \right\} e^{-j2\pi\alpha t} dt \quad (5)$$

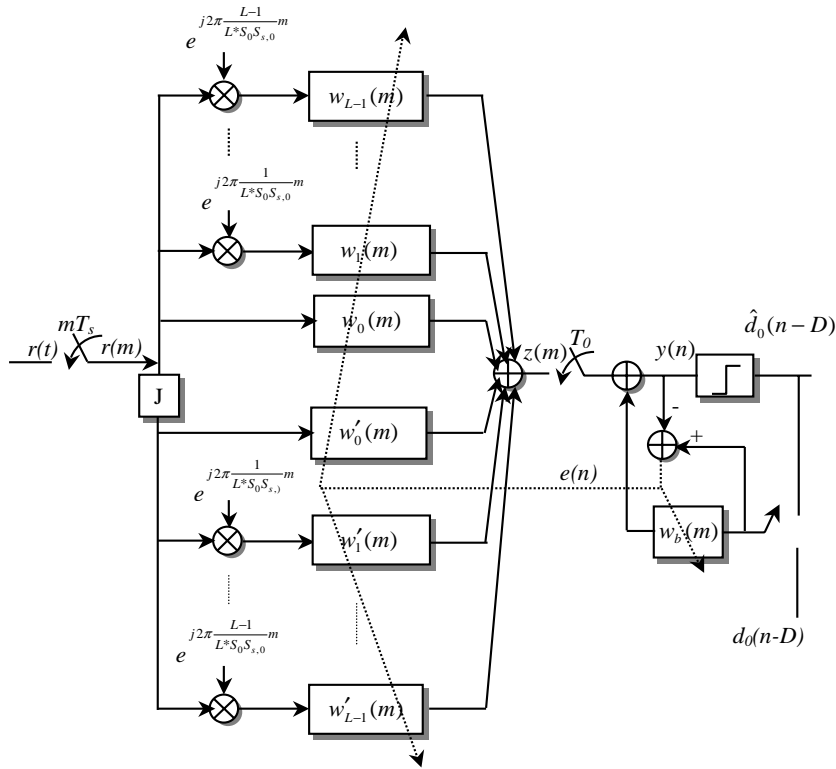

Figure 1. The FRESH-DFE filter structure for multi-access CDMA systems

A complex valued time series $x(t)$ is said to be cyclostationary if either its CA or its CCA is not identically zero for $\alpha \neq 0$. The cyclostationary property of a signal leads to spectral redundancy [1].

A. Representation of Stationary Process

A continuous time CRP, $x(t)$, with period T can be represented by a set of jointly stationary processes $\{A_p(t) = 0, \pm 1, \pm 2, \dots\}$ as follows:

$$x(t) = \sum_{p=-\infty}^{\infty} A_p(t) \exp(j2\pi p t / T) \quad (6)$$

where, $A_p(t)$ is the p^{th} stationary component, and can be found from $x(t)$ by:[3,4]

$$A_p(t) = [x(t) \exp(-j2\pi p t / T)] \otimes w_T(t) \quad (7)$$

Where $w_T(t)$ is the ideal low pass filter with bandwidth $1/T$. This representation is referred to as harmonic-series representation (HSR) [5].

A discrete time CRP $\tilde{x}(n)$ with period P can be represented by a set of jointly stationary processes $\{Z_k(m) : k = 0, 1, 2, \dots, P-1\}$ as follows:

$$\tilde{x}(n) = \sum_{k=0}^{P-1} Z_k(\lceil n/P \rceil) \delta([n]_P - k) \quad (8)$$

Where $[n]_P$ is the remainder of n divided by P and $Z_k(m)$ called k^{th} stationary component, can be found from $\tilde{x}(n)$ by:

$$Z_k(m) = \tilde{x}(mP + k) \quad (9)$$

This representation is referred to as the time-series representation (TSR) [4].

III. CYCLOSTATIONARY PROPERTY OF DS/SS SIGNAL

Consider a DS/SS signal, $x(t)$ in which $x(t) = d(t)c(t)$. $d(t)$ is data signal which can have a form of digital modulated signal and $c(t)$ is pseudo random code. As indicated in [1], the cyclic frequency of the spread spectrum signal, $s(t)$ are multiples of the data frequency. The same result could be observed for CCSD. If the narrow band signal has QPSK modulation, the CCSD of the QPSK doesn't contain any cyclic spectrum related to the carrier frequency.

IV. FRESH-DFE IN MULTIRATE CDMA SYSTEMS

In this section, we develop FRESH-DFE using harmonic series representation (HSR). This system would be compared with conventional DFE by performing some simulations under different circumstances. FRESH-DFE using TSR is developed in [2] and it is shown that this filter has better performance than conventional DFE. The structure of FRESH-DFE is shown in Fig. (1). By adding a feedback to the DFE filter and

using NLMS algorithm for coefficient determination, The FRESH-DFE for multi-rate CDMA systems is acquired.

V. SIMULATION RESULTS

The simulations are done for both the DL and UL paths and the BER of the conventional DFE and FRESH-DFE would be compared.

A. DL Path Simulation

Although there is no analytical equation between MSE & BER, the practical experiments show that by decreasing BER, the MSE will also decrease.

In this section we compare the BER of the FRESH-DFE and conventional DFE in different conditions for fading channel in the DL path.

At first, a system, which contains 3 users with SF=8 and 3 users with SF=32, is considered. Since the desired user has SF=8, the number of filters in linear and conjugate path of the FRESH filter becomes $32/8 = 4$. The error of the desired users, which is assumed to have BPSK modulation, is depicted in Fig (2). The better performance of the FRESH-DFE is apparent. In similar situations, the performance of the FRESH-DFE for QPSK modulation is better than the conventional DFE but the difference is not as much as BPSK (Fig (3)).

Note that there is inappreciable difference between conventional DFE & FRESH-DFE in QPSK modulation. The reason for this performance difference between QPSK and BPSK is laid in the symmetric frequency spectrum of BPSK. Contrary to the QPSK, the frequency spectrum in BPSK is symmetric around the carrier frequency. If a conjugate branch is added to the FRESH-DFE receiver, the correlation between the two symmetric portions of the frequency spectrum will be extracted.

In the next simulation, the difference between bit-rates is decreased. In this case the first three users have SF=8 and the second 3 users have the SF=16. The number of filters in the linear and conjugate path becomes $16/8$.

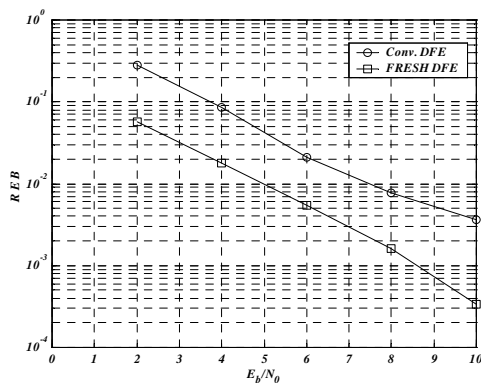

Figure 2. The BER vs. SNR evaluation for BPSK CDMA system, which contains 3 users with SF=8 and 3 users with SF=32, in the DL path

The error is plotted as a function of SNR in Fig (4) and Fig (5) for BPSK & QPSK modulations. It is cleared that the

performance of the FRESH-DFE is better than conventional DFE.

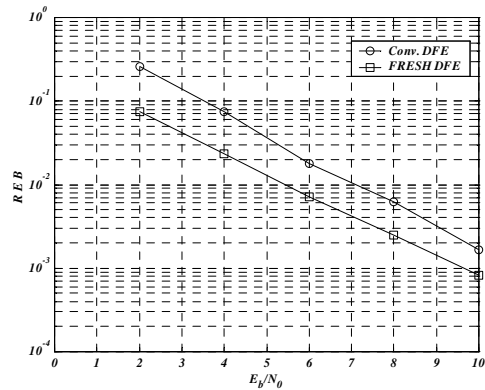

Figure 3. The BER vs. SNR evaluation for QPSK CDMA system, which contains 3 users with SF=8 and 3 users with SF=32, in the DL path

Since the number of filters and effective interference, caused by other users, decreased, it is expectable that the difference between the performance of the FRESH-DFE & DFE decreases.

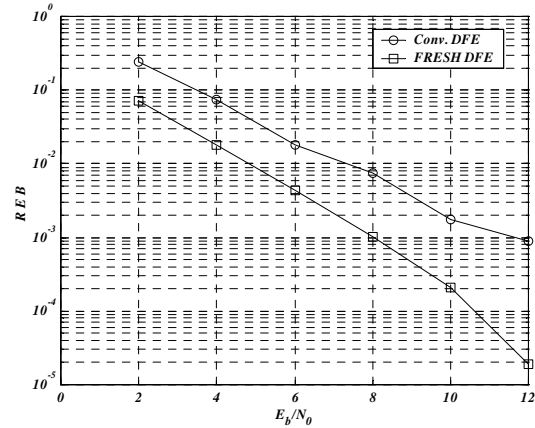

Figure 4. The BER vs. SNR evaluation for BPSK CDMA system, which contains 3 users with SF=8 and 3 users with SF=16, in the DL path

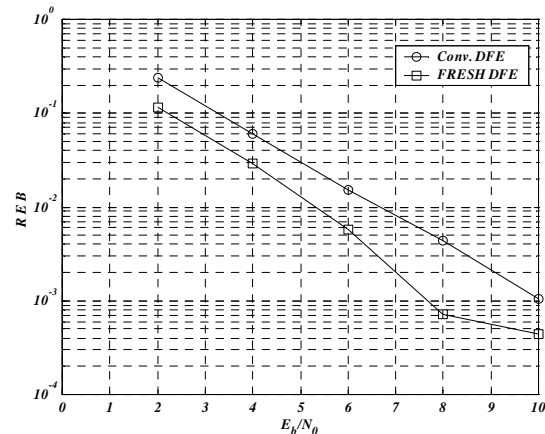

Figure 5. The BER vs. SNR evaluation for QPSK CDMA system, which contains 3 users with SF=8 and 3 users with SF=16 in the DL path

In the next simulation, the number of different service classes increases. In this case the first two users have the SF=8 the second two users have the SF=16 and the third two users have the SF=32. The desired user has the SF=8, so 4 filters are placed in each of the linear and conjugate path of the FRESH-DFE. The Fig.6 & Fig.7 show the BER of DFE & FRESH-DFE in the case of BPSK & QPSK modulations respectively.

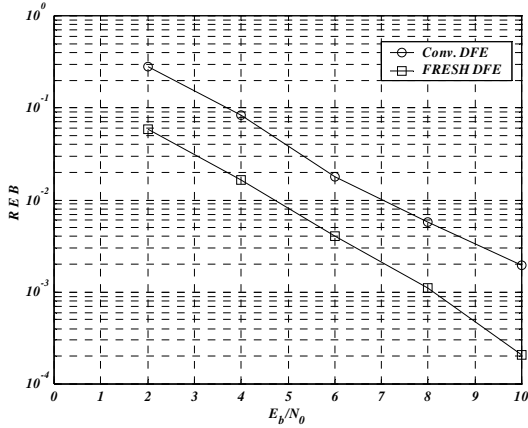

Figure 6. The BER vs. SNR evaluation for BPSK CDMA system, which contains 2 users with SF=8, 2 users with SF=16 and 2 users with SF=32, in the DL path

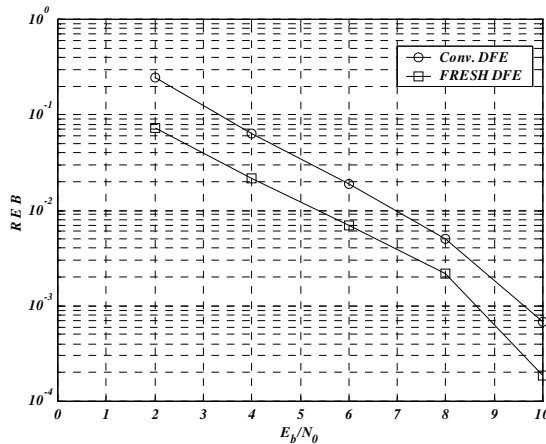

Figure 7. The BER vs. SNR evaluation for QPSK CDMA system, which contains 2 users with SF=8, 2 users with SF=16 and 2 users with SF=32, in the DL path

B. UL Path Simulations

Like DL path, the BER vs. SNR of BPSK & QPSK modulations is acquired. The simulated system has 3 users with SF=8 and 3 users with SF=32. The difference between FRESH-DFE & conventional DFE performance become more significant in comparison to DL path simulations. BER as a function of SNR for the indoor channel is illustrated in Fig. 8 & Fig. 9.

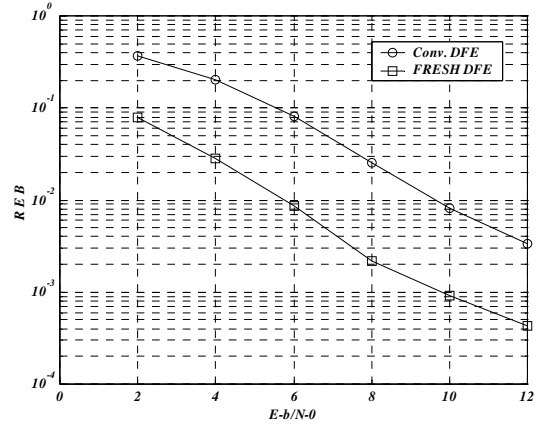

Figure 8. The BER evaluation for BPSK CDMA system, which contains 3 users with SF=8 and 3 users with SF=32, in the UL path

BER as a function of SNR for the indoor channel in different conditions is illustrated in Fig. 10 & Fig. 11. It is cleared that the FRESH-DFE shows less BER than conventional DFE in all the figures.

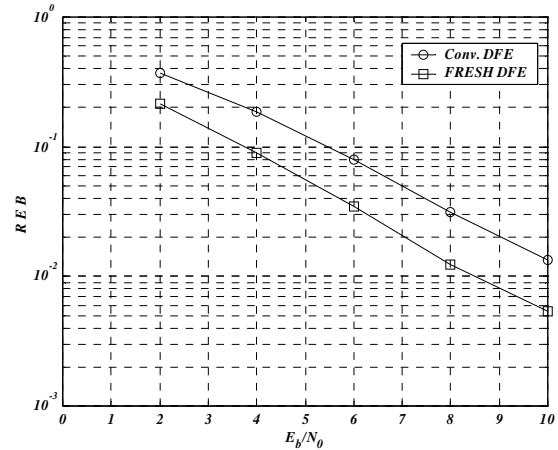

Figure 9. The BER evaluation for QPSK CDMA system, which contains 3 users with SF=8 and 3 users with SF=32, in the UL path

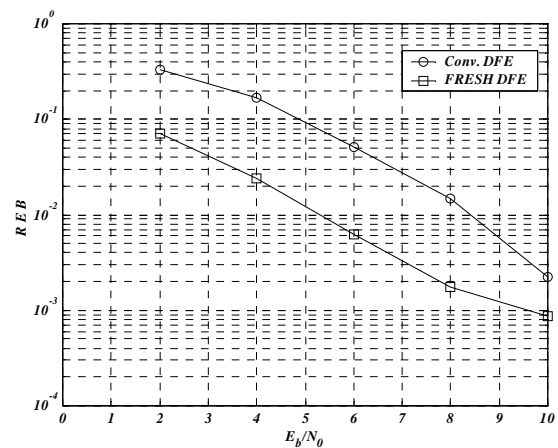

Figure 10. The BER evaluation for BPSK CDMA system, which contains 2 users with SF=8, 2 users with SF=16 and 2 users with SF=32, in the UL path

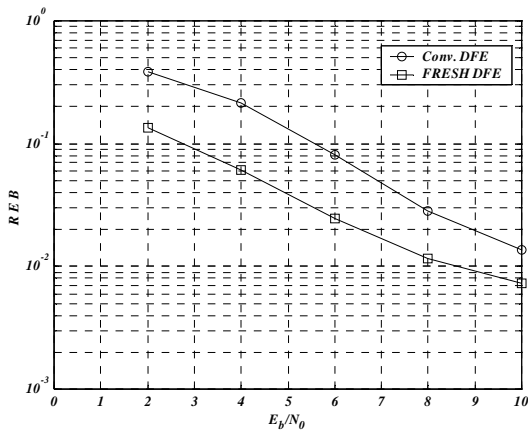

Figure 11. The BER evaluation for QPSK CDMA system, which contains 2 users with SF=8, 2 users with SF=16 and 2 users with SF=32, in the UL path

VI. CONCLUSION

In this paper we developed the interference cancellation in multi-rate CDMA systems. To achieve a suitable interference canceller, the structure of the two different filters, FRESH-DFE and conventional DFE, are compared. It has been shown that for a CDMA system, FRESH-DFE can exploit the cyclostationary property of the signal and show the better performance than conventional DFE in all cases. The FRESH-DFE exploits the spectral redundancies, which is caused by the cyclostationary property, and it can reach much less BER than conventional DFE in the same SNR.

A set of simulations were done for indoor fading channel to compare the performance of DFE & FRESH-DFE. It is illustrated that the FRESH-DFE shows a better performance. The amount of performance improvement in FRESH-DFE is dependant on different conditions such as modulation type, number of cyclic frequencies, number of users and number of different bit-rates in multi access systems. In all simulations, BPSK modulated signals show higher spectral redundancy than QPSK and properly restored by the FRESH-DFE.

REFERENCES

- [1] Hendessi, F., On the theory of FRESH_DFE and its application in digital cellular radio systems, PhD Thesis, Department of Systems and computer engineering, Carlton University, Ottawa, Canada, 1994
- [2] Mangalvedhe N.R., Development and Analysis of adaptive interference rejection techniques for direct sequence code division multiple access systems, PhD Thesis, Virginia Polytechnic Institute and State University, USA, 1999
- [3] L.E. Franks and W.A. Gardner, "Estimation of cyclostationary random processes," in Proc, 9th Annu. Allerton Conf. Circuit and System Theory, pp. 222-231, 1971.
- [4] W.A. Gardner, Introduction to Random Processes with Application to Signals and Systems. New York: Mcmillan, 1985: second ed. Mc Graw-Hill, 1990.
- [5] W.A. Gardner, Statistical Spectral Analysis: A Nonprobabilistic Theory. Englewood Cliffs, NJ: Prentice-Hall, 1987,
- [6] "Probability and Random Processes for Electrical Engineering", Second Edition, Alberto Leon-Garcia
- [7] Proakis, J.G., Digital communications, Mc Graw-Hill, 1995