

LOSS-MINIMIZATION CONTROL OF SCALAR-CONTROLLED INDUCTION MOTOR DRIVES

Hussein Sarhan, Rateb Al-Issa, and Qazem Jaber

Department of Mechatronics Engineering, Faculty of Engineering Technology
Al-Balqa' Applied University, Amman, P O Box 15008, Jordan

Abstract - The efficiency of induction motor drives under variable operating conditions can be improved by predicting the optimum flux that guarantees loss minimization. In this paper, a loss-minimization scalar controller, based on determining of modulation index of IGBT inverter-based AC-to-AC converter, which corresponds to optimum flux, is proposed. For this purpose, mathematical models for total power losses as a function of magnetic flux, optimum flux as a function of operating speed and load torque, and modulation index as a function of optimum flux were analytically derived. Loss-minimized, scalar-controlled induction motor drive system was modeled, simulated and experimentally tested. The results have validated the effectiveness of this system in minimizing the motor operating losses, especially at light and medium loads. Also, the dynamic performance of the drive system has been improved. The proposed controller can be implemented in adjustable speed induction motor drive systems with variable loads, operating below rated speed.

Key Words - Induction Motor Drive, Loss Minimization, Scalar Control, Optimized Flux.

Nomenclature:

ΔP_{tot} = total power losses, W
 R_1 = stator resistance, Ω
 R_2' = rotor resistance referred to the stator, Ω
 I_1 = stator current, A
 I_2' = rotor current referred to the stator, A
 I_0 = magnetizing current, A
 I_{0n} = nominal magnetizing current
 $\Delta P_{mag,n}$ = magnetic losses at nominal operating conditions, W
 $\varphi = \frac{\phi}{\phi_n}$ = normalized (relative) flux, p.u
 ϕ = operating flux, Wb
 ϕ_n = nominal flux, Wb
 $\alpha = \frac{f}{f_n}$ = normalized (relative) frequency, p.u
 f = operating frequency, Hz
 f_n = nominal frequency, Hz
 k = coefficient depending on the type of steel used in core construction, usually = 1.3-1.5

$\mu = \frac{T}{T_n}$ = normalized torque, p.u

T = load torque, N.m

T_n = nominal load torque, N.m

$P_{ag,n}$ = nominal air-gap (electromagnetic) power, W

E_{1n} = nominal e.m.f., V

P_{in} = nominal input power, W

I_{1n} = nominal stator current, A

P_n = nominal output power, W

ω_s = synchronous speed, rad/s

a, b = coefficients of analytical approximation of magnetization curve

V_n = nominal stator voltage, V

I. INTRODUCTION

Induction motors are the most used in industry since they are rugged, inexpensive, and are maintenance free. It is estimated that more than 50% of the world electric energy generated is consumed by electric machines. Improving efficiency in electric drives is important, mainly for economic saving and reduction of environmental pollution [1, 2]. Induction motors have a high efficiency at rated speed and torque. However, at light loads, motor efficiency decreases dramatically due to an imbalance between the copper and the core losses. Hence, energy saving can be achieved by proper selection of the flux level in the motor [3, 4]. The main induction motor losses are usually split into: stator copper losses, rotor copper losses, core (iron) losses, mechanical and stray losses. To improve the motor efficiency, the flux must be reduced, obtaining a balance between copper and core losses. Many minimum-loss control schemes based on scalar control or vector control of induction motor drives have been reported in literature [4]–[8]. Basically, there are two different approaches to improve the efficiency: loss-based model approach and power measure based approach [6]–[8]. In loss based model approach the loss minimization optimum flux or power factor is computed analytically, while in power measure based approach the controller searches for the operating point where the input power is at a minimum while keeping the motor output power constant. The proposed in literature various methods for loss-minimizing control of induction motors differ each other by approach, complexity, accuracy, convergence, etc. [9, 10].

In this paper, a loss-minimization scalar controller of induction motor drive system, based on calculating the optimal flux for loss minimization, is developed. Then, the validity of the proposed controller was examined by simulation and experimental results. Further, the effect of loss-minimization

scheme on the dynamic performance of the drive system was investigated.

II. ALGORITHM OF THE MINIMUM-LOSS CONTROL

The total power losses ΔP_{tot} in induction motor can be calculated by the following equation [11, 12]:

$$\Delta P_{\text{tot}} = 3R_1 I_1'^2 + 3R_2' I_2'^2 + \Delta P_{\text{mag.n}} \varphi^2 \alpha^k \quad (1)$$

The magnetic losses at nominal operating conditions $\Delta P_{\text{mag.n}}$ can be approximately defined as:

$$\Delta P_{\text{mag.n}} = P_{1n} - P_{\text{ag.n}} - (3R_1 I_{1n}'^2 + 0.005P_n) \quad (2)$$

The relationship between stator current I_1' , rotor current I_2' and magnetizing current is given by [8]

$$I_1'^2 \approx I_2'^2 + I_0'^2 \quad (3)$$

Also, the rotor current I_2' can be represented as:

$$I_2' = \frac{P_{\text{ag.n}} \mu}{E_{1n} \varphi} \quad (4)$$

The nominal air-gap (electromagnetic) power is:

$$P_{\text{ag.n}} = T_n \omega_s \quad (5)$$

According to analytical analysis provided in [13], the magnetizing current I_0 can be expressed as:

$$I_0'^2 \approx I_{0n}'^2 \frac{a(1-\varphi^2) + \varphi^2}{b(1-\varphi^2) + \varphi^2} \quad (6)$$

The coefficients a and b are selected so as most exactly describe the segment of magnetization curve, located in the interval of optimum flux variation.

Substitution of (3), (4), and (6) into (1) yields

$$\Delta P_{\text{tot}} = B \frac{a(1-\varphi^2) + \varphi^2}{b(1-\varphi^2) + \varphi^2} + C \frac{\mu^2}{\varphi^2} + D \varphi^2 \alpha^k \quad (7)$$

where

$$B = 3R_1 I_{0n}'^2 \quad (8)$$

$$C = \frac{(R_1 + R_2') P_{\text{ag.n}}^2}{3E_{1n}^2} \quad (9)$$

$$D = \Delta P_{\text{mag.n}} \quad (10)$$

(7) shows that the total power losses at specified frequency and load torque are a function of normalized magnetic flux only. Taking the derivative of ΔP_{tot} with respect to φ in (7) and equating the derivative to zero yields

$$\varphi^8 + a_1 \varphi^6 + a_2 \varphi^4 + a_3 \varphi^2 + a_4 = 0 \quad (11)$$

where

$$a_1 = \frac{2b}{1-b} \quad (12)$$

$$a_2 = \left(\frac{b}{b-1} \right)^2 + \frac{2B(b-a) - C\mu^2(b-1)^2}{D\alpha^k(b-1)^2} \quad (13)$$

$$a_3 = \frac{2C\mu^2 b}{D\alpha^k(b-1)} \quad (14)$$

$$a_4 = -\frac{C\mu^2 b}{D\alpha^k(b-1)^2} \quad (15)$$

(11) has 8 roots, 6 of them are complex, one real negative root, and one real positive root. The complex roots and the negative root have no physical meaning and should be ignored. The remaining real positive root will be the optimal normalized flux φ_{opt} , which corresponds to minimum power losses.

The optimum value of control command, modulation index m_{opt} , can be defined as:

$$m_{\text{opt}} = \alpha \varphi_{\text{opt}} \quad (16)$$

The last equation shows how the magnetic flux should be changed to achieve energy saving at different operating conditions. Also, it is the control algorithm of the proposed loss-minimization controller. The optimal value of modulation index is always ≤ 1 .

The optimal value of stator voltage V_{opt} that minimizes the total power losses is:

$$V_{\text{opt}} = m_{\text{opt}} V_n \quad (17)$$

III. MODELING AND SIMULATION OF OPTIMIZED DRIVE SYSTEM

The drive system studied in this paper consists of IGBT-inverter-based AC to AC converter, three-phase squirrel cage induction motor and controller. In order to analyze the system performance, all of these components should be modeled (mathematically described). According to the analysis done in [5], the converter will be modeled through its input-output equation based on the modulation index, and the standard state-space model will be used to model the induction motor. (16) represents the mathematical model of the controller.

The block diagram of the drive system studied using MATLAB Simulink is shown in Fig. 1.

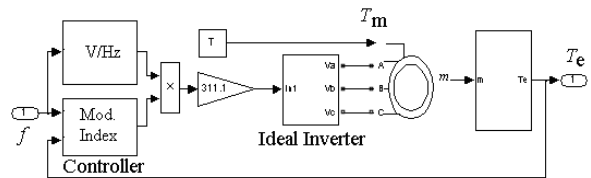

Fig. 1. Model of optimized drive system.

The parameters of modeled and simulated induction motor are given in table 1.

The MATLAB Simulink model of optimal flux φ_{opt} is shown in Fig. 2. The model is used to define the real positive root of (11). The condition $0 < \varphi_{\text{opt}} \leq 1$ was considered in the

model. The required coefficients in (1) were simulated according to (12) - (15).

The relationship between optimal flux, frequency, and load torque is shown in Fig. 3. It is clear from Fig. 3 that there is certain value of optimal flux for each operating point.

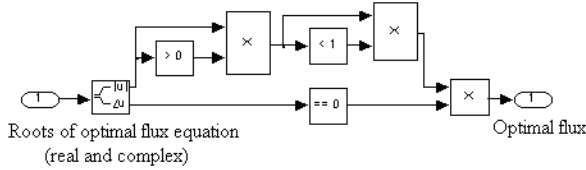

Fig. 2. Model of optimal flux φ_{opt} .

TABLE I
INDUCTION MOTOR DATA

Parameter	Value
Stator resistance R_1	1.230 Ω
Stator reactance X_1	1.500 Ω
Mutual reactance X_m	53.700 Ω
Rotor resistance referred to the stator R'_2	0.787 Ω
Rotor reactance referred to the stator X'_2	2.490 Ω
Nominal voltage V_n	220/380 V
Nominal torque T_n	36.340 N.m
Nominal output power P_n	5.500 kW
Nominal stator current I_{1n}	11.500 A
Nominal power factor $\cos \varphi_n$	0.850
Nominal frequency f_n	50 Hz
Number of poles P	4
Nominal slip s_n	0.036
Synchronous rotational speed n_s	1500 rpm
Synchronous angular speed ω_s	157 rad / s
Nominal rotational speed n_n	1446 rpm
Nominal angular speed ω_n	151.348 rad / s
Moment of inertia J	0.017 kg.m ²
Constant a	0.0327
Constant b	3.112
Coefficient k	1.400

In order to validate the effectiveness of the proposed controller, a motor loss model is required. This model is shown in Fig. 4.

The model was constructed according to (7)-(10). Examples of total power losses plots as a function of stator voltage (flux) under various load torques and frequencies are shown in Figs. 5 and 6, from which it can be seen that there is an optimal value of stator voltage (flux) for each operating point, where the total power losses are minimum.

For quantitative analysis, the total power losses in the optimized system were compared with those in the original (non-optimized) system under the same operating conditions. The original system is considered that one, in which the stator voltage (flux) remains constant and equals the nominal value for all operating conditions. Examples of total power losses plots in

original and optimized systems are shown in Figs. 7 and 8, which show that the proposed optimization approach has significant effect at light loads.

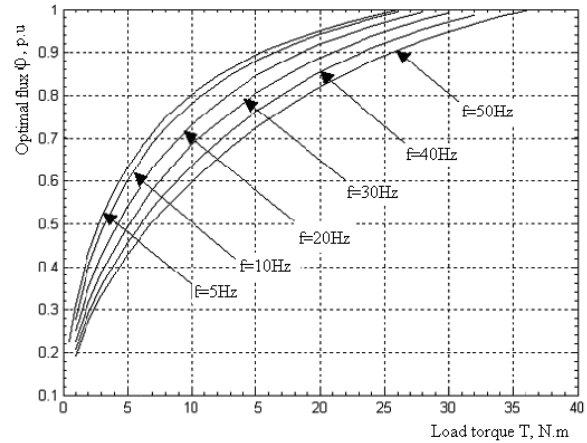

Fig. 3. Optimal flux as a function of load torque at variable frequency.

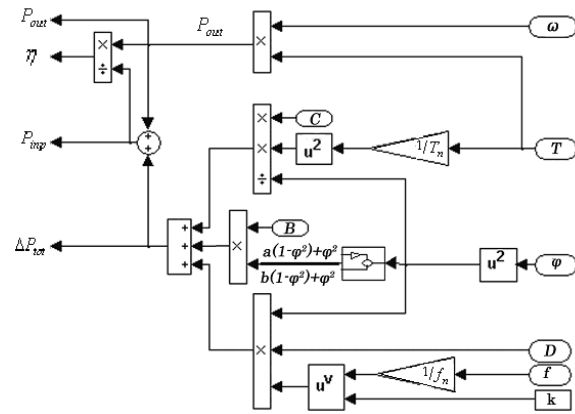

Fig. 4. Motor loss model.

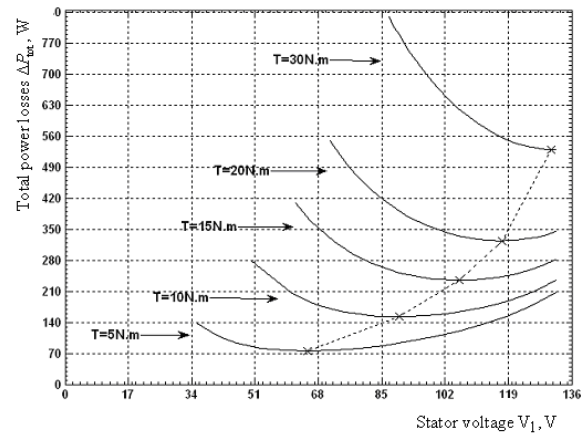

Fig. 5. Total power losses as a function of stator voltage under variable load torques and frequency $f = 30\text{Hz}$.

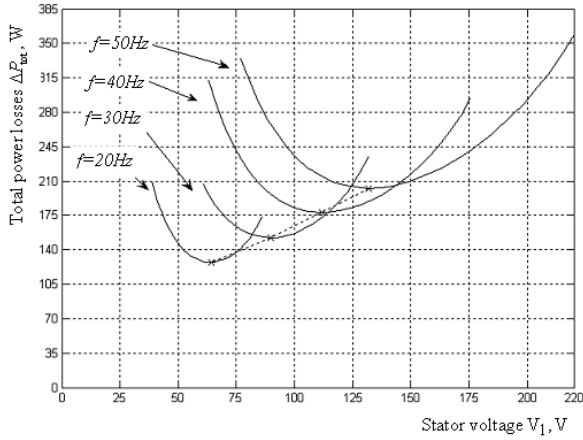

Fig. 6. Total power losses as a function of stator voltage under variable frequencies and load torque $T = 10\text{N.m}$.

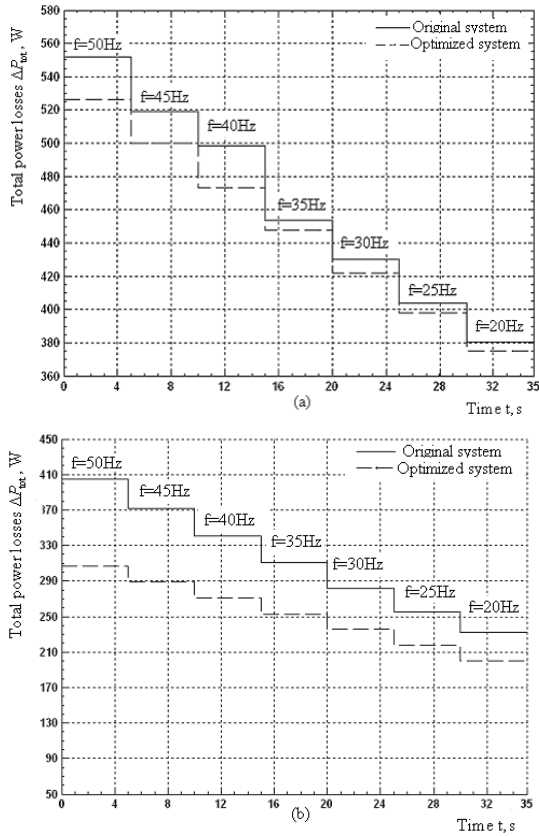

Fig. 7. Total power losses in original system and optimized system under variable frequencies. (a) Load torque $T = 25\text{N.m}$ and (b) load torque $T = 15\text{N.m}$.

Effect of optimization on the system dynamics has been investigated. Simulation results show that the dynamic responses of stator current, electromagnetic torque, and angular speed had been improved. Examples of dynamic responses of both optimized and original systems are shown in Figs. 9, and

10. Also, it was noticed in some cases, that there is a very small increase in slip, as shown in Fig. 10. This can be explained as a result of decrease in dynamic torque causing motor acceleration due to decrease in magnetic flux.

IV. EXPERIMENTAL RESULTS

To verify the use of the proposed loss-minimization controller some experiments have been carried out with the same drive system that was simulated. The total power losses were experimentally obtained for different operating conditions as the difference between the input power and the output power. The input power was measured for each operating point, while the corresponding output power was calculated as $P_{out} = T\omega$. The experimental results were compared with theoretical results. Some of these results are represented in Fig. 11, which shows that there is some deviation between experimental and theoretical results. This is due to the assumptions and approximations done during loss model derivation and due to the losses in other components of the drive system.

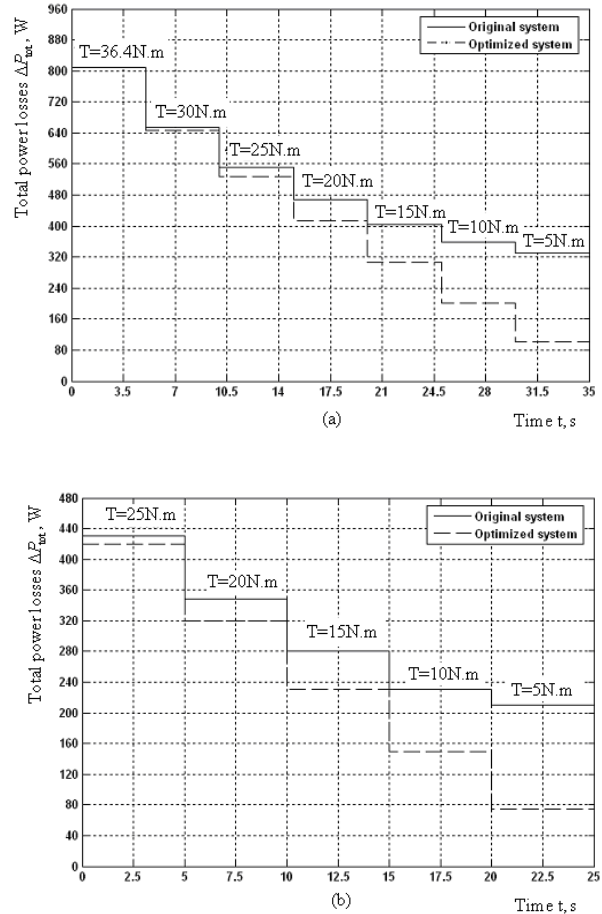

Fig. 8. Total power losses in original system and optimized system under variable loads. (a) Frequency $f = 50\text{Hz}$ and (b) frequency $f = 30\text{Hz}$.

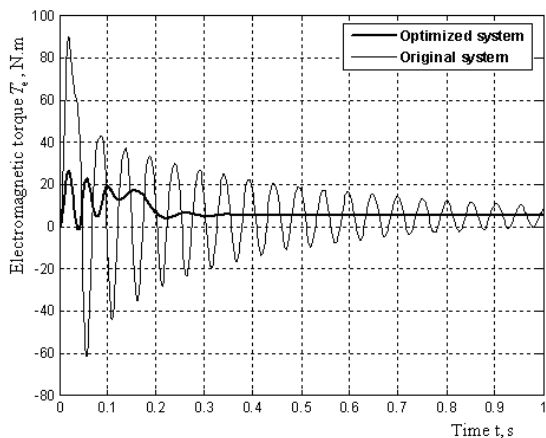

Fig. 9. Dynamic response of electromagnetic torque at load torque $T = 5\text{N.m}$ and frequency $f = 30\text{Hz}$.

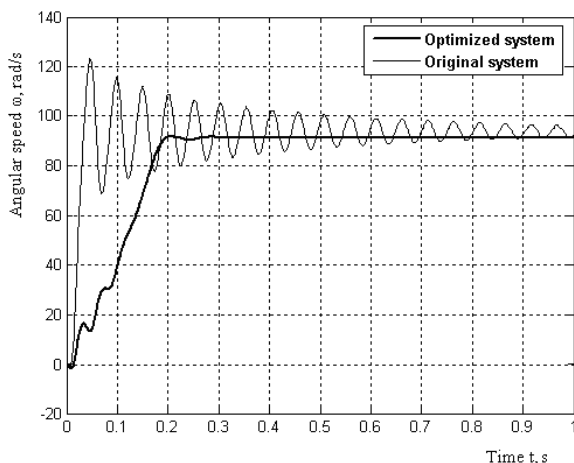

Fig. 10. Dynamic response of angular speed at load torque $T = 5\text{N.m}$ and frequency $f = 30\text{Hz}$.

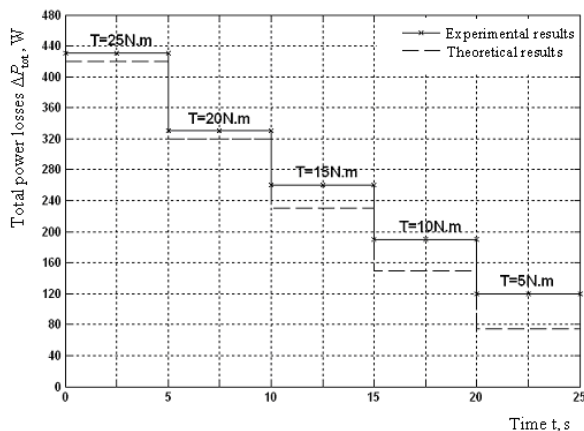

Fig. 11. Experimental and theoretical power losses in the drive system for variable load torque and constant frequency 30Hz.

V. CONCLUSIONS

In this paper, the loss minimization in induction motor drive systems through the magnetic flux has been derived and examined. The control scheme utilizes modulation index of IGBT-inverter-based AC to AC converter as the main control variable and manipulates the stator voltage in order for the motor to operate at its minimum-loss point. The proposed controller can be used in adjustable speed induction motor drive systems operating with variable loads. The total power losses can be decreased significantly at light loads. However, in some cases, slip compensation is required. Simulation results show that the dynamic performance of the optimized system has been improved.

REFERENCES

- [1] W. Leonhard, "Controlled AC drives, a successful transfer from ideas to industrial practice", *CETTI 95*, Brazil, September 11-12, pp. 1-12, 1995.
- [2] G.C.D. Sousa, B.K. Bose, J.G. Cleland, "Fuzzy logic based on-line efficiency optimization control of an indirect vector-controlled induction motor drive", *IEEE Transactions on Industrial Electronics*, vol. 42, no. 2, pp. 192-198, April 1995.
- [3] H.R. Andersen, C.B. Rasmussen, E. Ritchie, J.K. Pedersen, "Efficiency comparison of electrical motors for energy optimized variable speed low power and low cost household equipment", *6th European Conference on Power Electronics and Applications, EPE' 95*, vol. 3, pp. 3381-3386, Seville, Spain, 1995.
- [4] F.C. Lin, S.M. Yang, "On-line tuning of an efficiency-optimized vector controlled induction motor drive", *Tamkang Journal of Science and Engineering*, vol. 6, No. 2, pp. 103-110, 2003.
- [5] H. Sarhan, R. Issa, "Modeling, simulation and test of inverter-induction motor drive system with improved performance", *Journal of engineering sciences, Assiut university*, vol. 33, No. 5, pp. 1873-1890, 2005.
- [6] F. Abrahamsen, J.K. Pedersen, F. Blaabjerg, "State-of-the-art of optimal efficiency control of low cost induction motors drives", *PEMC'96*, vol. 2, pp. 163-170, Budapest, Hungary, September 2-4, 1996.
- [7] I. Kioskeridis, N. Margaris, "Loss minimization in induction motor adjustable-speed drives", *IEEE Transactions on Industrial Electronics*, vol. 43, no. 1, pp. 226-231, February 1996.
- [8] Kioskeridis, N. Margaris, "Loss minimization in scalar-controlled induction motor drives with search controllers", *IEEE Transactions on Power Electronics*, vol. 11, no. 2, pp. 213-220, March 1996.
- [9] F. Abrahamsen et al, "Efficiency-optimized control of medium-size induction motor drives", *IEEE Transactions on Industry Applications*, vol. 37, No. 6, pp. 1761-1767, November/ December 2001.
- [10] S. M. Yang, F. C. Lin, "Loss-minimization control of vector-controlled induction motor drives", *Journal of the Chinese Institute of Engineers*, vol. 26, No. 1, pp. 37-45, 2003.
- [11] E.I Epshtien, *AC drives*, Moscow, p. 190, 1982.
- [12] S. Lim, K. Nam, "Loss-minimizing control scheme for induction motors", *IEE Proc.-Electr. Power Appl.*, vol. 151, No. 4, pp. 385-394, July 2004.
- [13] V.N. Brodovsky, I.S. Ivanov, "Drives with frequency-current control", *Energy*, Moscow, pp.169, 1975.