

Soft Sensor for NO_x Emission using Dynamical Neural Network

M. Shakil, M. Elshafei, M. A. Habib and F. Al-Maleki*
King Fahd University of Petroleum and Minerals,
Saudi Petrochemical Co. (Sadaf)* Saudi Arabia

Abstract—In this paper we propose a soft sensor for prediction of NO_x emission from the combustion unit of industrial boilers. The soft sensor is based on a dynamical neural network model. A simplified structure of the dynamical neural network model is achieved by grouping the input variables using basic knowledge of the system. Neural network model is trained using real data logs of an industrial boiler. Principal Component Analysis (PCA) is used to reduce number of input variables. Lag space for the model is found by using genetic algorithm to find the best time delayed model. Lag space obtained from the linear model is then used for constriction of the dynamical neural network. The proposed model is validated using different data from the same boiler and its ability to accurately predict NO_x emission from the boiler is demonstrated.

I. INTRODUCTION

NO_x is one of the pollutants which is emitted from the combustion units of industrial boilers. Strict environmental rules regarding air pollution are being implemented in different parts of the world. These rules require combustion processes to limit NO_x emission to certain regulatory limits. Boiler operators and control systems require on-line NO_x measurements to operate the boilers at the best efficiency while maintaining the emission level within the regulatory limits.

Measurement of NO_x is traditionally achieved by installing hardware sensors or analyzers termed Continuous Emission Monitoring System (CEMS). CEMS suffer from a number of drawbacks including significant capital investment, high operation and maintenance cost of hardware, drift and errors due to ambient temperature and humidity, measurement interference due to other gases and pollutants, and long sample period. As such, software-based approaches have been proposed to infer the emission concentration from other process measurements. These sensors are commonly referred to as Inferential Sensors or soft sensors.

Soft sensors provide an alternate solution for prediction of a certain quantity, when primary equipment is not working or it is not available due to temporary maintenance. Soft sensors are cost effective as compared to primary equipment used for direct measurement. NO_x formation is a complex process. It depends on the temperature distribution inside the combustion chamber, inlet air flow rate, inlet air temperature, fuel flow rate, air-to-fuel ratio, fuel type, etc.

Soft sensor methods have been applied for NO_x prediction by many researchers. Lin et-al [1] proposed a systematic way

of developing soft sensors. They suggested key steps like removal of outliers, mapping the data and dimension reduction of input variables. Qin et-al [2] discussed a self-validating soft sensor based on Principal Component Analysis. They suggested that validated principal components can be used to predict the output variables. Dong and McAvoy [3] discussed soft sensor based on neural network partial least square and nonlinear principal component analysis. They discussed that proposed sensor based on NNPLS can be applied for NO_x prediction. They used NLPCA for data analysis only. Elshafei et-al [4] proposed soft sensor based on polynomial network for prediction of NO_x and O₂ from combustion unit of a water tube boiler. They created CFD (Computational fluid dynamics) model of combustion process and used data from model to train neural network. Yang and Blasaik [5] developed a soft sensor for study of variation of excess air on NO formation in a furnace. Ahmed [6] proposed soft sensors for NO_x prediction from industrial water tube boilers. He discussed soft sensors based on different types of static neural networks, training algorithms and compared them. Traver et-al [7] used neural network for prediction of emission from a 300HP diesel engine.

In most of the above soft sensors for NO_x prediction static neural neural network has been used. Formation of NO_x has certain dynamical behavior [8]-[5]-[4], and proper modeling of these dynamics and system time delays could lead to a better NO_x prediction. A dynamical neural network model can capture both the systems nonlinearities and dynamics[9]-[10]. In this paper, we present a data driven dynamical neural network soft sensor.

II. NO_x FORMATION

Boiler unit considered here is a water tube type boiler fired by natural gas in combination with other fuels [6]. Boiler unit has temperature sensors at the superheater tubes and the riser tubes to monitor overheating of these tubes. However, there is no direct temperature measurement of the temperature distribution in the combustion chamber. These so called "skin temperatures" are used as replacement of the combustion temperature measurements. Six skin temperatures were considered in this study. Firing gas flow rate, secondary fuel flow rate, and air flow rates are being measured at the input of combustion unit.

NO_x formation in combustion chambers is due to three mechanisms; thermal, fuel, and prompt NO_x. Thermal NO_x

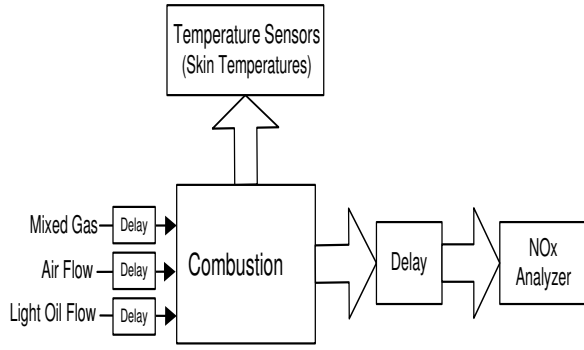

Fig. 1. NO_x Emission

is controlled by the nitrogen and oxygen molar concentrations and the temperature of combustion. Combustion well below 1,300C° forms much smaller concentrations of thermal NO_x. However, the rate of generation of thermal NO_x increases rapidly with higher flame temperatures.

Fuels that contain nitrogen (e.g., coal) create fuel NO_x that results from oxidation of the already-ionized nitrogen contained in the fuel. On the other hand, prompt NO_x is formed from molecular nitrogen in the air combining with fuel in fuel-rich conditions which exist, to some extent, in all combustion. This nitrogen then oxidizes along with the fuel and becomes NO_x during combustion, just like fuel NO_x. NO_x formation in industrial boilers (over 100 MW) is dominated by thermal NO_x [4]-[8]. Figure 1 shows a basic diagram for NO_x emission. NO_x is formed in the combustion unit. The dynamics of the system includes the combustion dynamics, the transportation delay, the time constant of the analyzer and the analyzer time delay.

III. DATA DIMENSION REDUCTION

Principal Component Analysis [11] is a technique to reduce high dimension data to a lower dimension feature data. PCA has been successfully applied for dimension reduction by researchers [2]-[3]. Data is normalized before applying principal component analysis. PCA is applied to six skin temperatures to reduce temperature data. It was observed that three skin temperatures had very low eigen values. Corresponding eigen vectors were removed from feature matrix.

IV. MODEL STRUCTURE

Dynamical model in figure 1 can be expressed by following nonlinear equation.

$$y = f(g(\cdot), h(\cdot), y^{k-1}) \quad (1)$$

Where y is output(NO_x emission). $g(\cdot)$ and $h(\cdot)$ are nonlinear functions of the feature data input. These function will be discussed in section V. It is very difficult to find the lag space for the dynamical model. We first find a dynamical linear model that provides best relation between output(NO_x) and inputs feature vector in terms of MSE. Linear model have the

form,

$$\begin{aligned} \bar{y}(k) = & b_1 u_1(k - d_1) + b_2 u_2(k - d_2) \\ & + b_2 u_3(k - d_3) + b_4 u_4(k - d_4) \\ & + b_5 u_5(k - d_5) + b_6 u_6(k - d_6) \\ & + a_1 \bar{y}(k - p_1) \end{aligned} \quad (2)$$

Where \bar{y} is output (NO_x). u_1, u_2 and u_3 are inputs from temperature feature data. u_4, u_5 and u_6 are light oil flow, mixed gas set-points and air flow inputs. a_1 and b_1, \dots, b_6 are coefficients. p_1 and d_1, \dots, d_6 are system delays. Coefficients and delays in the system need to be identified. Above model structure is selected based on basic knowledge of system operation. Genetic algorithm is used to find the best linear model. Best system delays are used for construction of dynamical neural neural network model.

A. Genetic Algorithm

Genetic algorithm (GA) is population based iterative stochastic search algorithm. GA were first introduced by Holland [12]. GA find the best solution based on survival-of-the-fittest. The main idea is to represent the candidate solutions in the form of chromosomes. Each solution in the population has a *fitness* associated with it. The new population is created by genetic operators called *crossover* and *mutation*. Chromosomes may be represented in real numbers by their real values by using real coded genetic algorithm [13]. There are two main operators which reproduce the new population for next iteration.

1) *Reproduction*: Reproduction is the process of producing the new population for next search iteration, from previous population. The way new chromosomes are generated is also called *crossover*. Reproduction process is combination of crossover and mutation. BLX- α crossover algorithm is effective as compared to other types of crossovers in real coded genetic algorithm [13].

Let $C_1 = (c_1^1, \dots, c_n^1)$ and $C_2 = (c_1^2, \dots, c_n^2)$ be two chromosomes, which are selected for crossover. Where c_n^p is n -th gene in p -th chromosome. New chromosomes $H = (h_1, \dots, h_i, \dots, h_n)$ are generated by BLX- α algorithm. Where h_i is the randomly (uniformly) chosen number between interval,

$$\begin{aligned} h_i &= \text{random}[c_{min} - I\alpha, c_{max} + I\alpha] \\ c_{max} &= \max(c_i^1, c_i^2) \\ c_{min} &= \min(c_i^1, c_i^2) \end{aligned} \quad (3)$$

Where α is a number chosen between 0-1. It is GA parameter

2) *Mutation*: Mutation is the changing the solutions in population randomly. It prevents the genetic algorithm to stuck in local minima. Probability of changing a solution is usually very low. Coefficients and delays in model given by equation 2 can be found using GA. We have 14 parameters which are required for linear model. We are interested in delays p_1 and d_1, \dots, d_6 . These delays will be used for dynamical neural network model. Delays p_1 and d_1, \dots, d_6 are obtained by finding a best linear model using following cost function,

$$J = (y - \bar{y})^2 \quad (4)$$

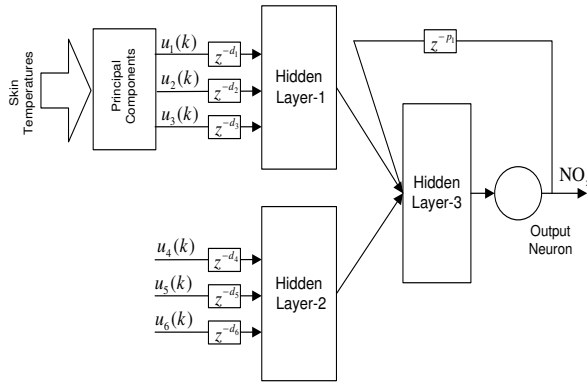

Fig. 2. Proposed Dynamical Neural Network Model

V. DYNAMICAL NEURAL NETWORK MODEL

Neural Networks can be divided into two categories, static neural networks and dynamic neural networks. Static neural networks provide nonlinear mapping between current inputs and current outputs. There are no delayed feedbacks or delayed inputs in static neural networks. Dynamical neural networks have memory in their structure in the form of delays in feed back or input or output. Memory is introduced by means of delays in inputs layer feedback connections. Dynamical neural network structure is highly dependent on order and complexity of the system [10]. Dynamical neural networks have been applied in system identification and modeling fields by researchers. Jesús and Hagan [14] discussed various training algorithms and structures for dynamical neural networks. Silva et-al [15] used nonlinear dynamical system identification based on hopfield neural network. They also discussed its stability issues.

Figure 2 shows the proposed neural network. Where $z^{-d_1}, \dots, z^{-d_6}$ and z^{-p_1} are delays which hold initial conditions. Neural network structure and configuration is selected from system knowledge and simulations. 8 Neurons are used in each hidden layer. Inputs in the first hidden layer are representing feature data inputs. Inputs in second layer represents air flow, light oil fuel flow and mixed gas set points. Third layer processes the output from layer-1 and layer-2. Output layers simply outputs the NO_x .

$f(g, h, y^{k-1})$ in Equation 1 is nonlinear function of $g(\mathbf{u}_f^{k-1})$, $h(\mathbf{u}_s^{k-1})$ and y^{k-1} . Where \mathbf{u}_s is the concurrent input vector of temperature feature data. \mathbf{u}_f is the concurrent input vector of light oil flow, mixed gas set-points and air flow. From the Figure 2 we observe that $h(\cdot)$ function is approximated in first layer, $g(\cdot)$ function is approximated in second layer and $f(\cdot, \dots)$ function is approximated in third layer. Temperature and Combustion data are processed in separate layers for better results.

VI. DYNAMICAL NEURAL NETWORK TRAINING

Total 1600 data points are used for training and 200 points are used for validation. Dynamic Neural Network showed in figure 2 is trained using series-parallel and parallel approaches

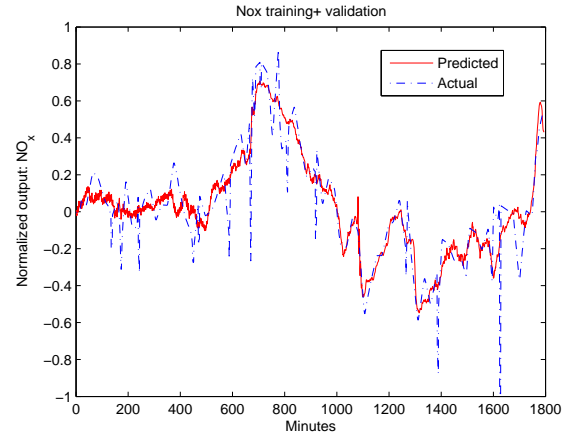

Fig. 3. Training and validation results

[16]. From simulations it is observed that parallel structures provides very good training but when it is validated on new data it becomes unstable. Several dynamic back propagation algorithms [14]-[16] were used for training dynamic neural network in figure 2. Bayesian regulation training algorithm [16] provided best results. Figure 3 shows the performance of the proposed dynamical neural network soft sensor on the training data and validation data.

VII. CONCLUSION

In this paper, We presented a soft sensor based on dynamical neural network model for NO_x prediction from industrial boilers. PCA is used to reduce the six temperature variables to three variables. System time delays were found using genetic algorithm. The Proposed Dynamical Neural Network Model demonstrated performance comparable with the CEM system.

VIII. ACKNOWLEDGMENT

We acknowledge the help of Saudi Petrochemical Co (Sadaf) for providing necessary data and technical information. The Authors would also like to acknowledge the support of King Fahd University of Petroleum and Minerals. This work is initiated by KFUPM/SABIC Project No. 2004/06.

REFERENCES

- [1] B. Lin, B. Recke, J. rgen K H Kundsens, and S. B. Jørgensen, "A systematic approach for soft sensor development," *Computers and Chemical Engineering*, vol. 31, pp. 419–425, May 2007.
- [2] S. J. Qin, H. Yue, and R. Dunia, "A self-validating inferential sensor for emission monitoring," in *Proceedings of American Control Conference*, Albuquerque New Mexico, June 1997, pp. 473–477.
- [3] D. Dong and T. J. McAvoy, "Emission monitoring using multivariate soft sensors," in *Proceedings of American Control Conference*, June 1995, pp. 761–765.
- [4] M. ElShafei, M. A. Habib, and M. Al-dajani, "Prediction of boilers emissions using polynomial networks," *IEEE Electrical and Computer Engineering Canadian Conference*, pp. 823–827, May 2006.
- [5] W. Yang and Wlodzimierz, "Mathematical modeling of no emissions from high-temperature air combustion with nitrous oxide mechanism," *Fuel Precessing Technology*, vol. 86, pp. 943–957, October 2004.
- [6] S. deen Iliyas Ahmed, "Emission monitoring systems using artificial neural networks," Master's thesis, King Fahd University of Petroleum and Minerals Saudi Arabia, May 2006.

- [7] M. L. Traver, R. J. Atkinson, and C. M. Atkinson, "Neural network-based diesel engine emission prediction using in-cylinder pressure," *International spring Fuels & lubricants meeting & Exposition*, May 1996.
- [8] P. Basu, *Combustion and Gasification in fluidized beds*. CRC Press Taylor and Francis group, 2006.
- [9] D. Mandic and J. Chambers, *Recurrent Neural Networks for Prediction: Learning Algorithms, Architectures and Stability*. Wiley, 2001.
- [10] S. Haykin, *Neural Networks. A comprehensive foundation*. Prentice hall International inc., 1999.
- [11] I. Jolliffe, *Principal Component Analysis*. Springer, 2002.
- [12] J. H. Holland, *Adaptation in natural and artificial systems*. The University of Michigan Press, 1975.
- [13] F. Herrera, M. Lozano, and J. L. Verdegay, *Tackling Real-Coded Genetic Algorithms: Operators and Tools for Behavioural Analysis*, ser. 4. Norwell MA USA: Kluwer academic publishers, August 1998, vol. 12.
- [14] O. D. Jesús and M. T. Hagan, "Backpropagation algorithms for a broad class of dynamic networks," *IEEE Transactions on Neural Networks*, vol. 18, no. 1, pp. 14–27, January 2007.
- [15] I. N. da Silva, W. C. do Amaral, and L. V. de Arruda, "A novel approach based on recurrent neural networks applied to nonlinear systems optimization," *Applied Mathematical Modeling*, vol. 31, pp. 78–92, January 2007.
- [16] H. Demuth, M. Beale, and M. Hogan, *Neural Network Toolbox for use with matlab*, 5th ed., The MathWorks, Inc. 3 Apple Hill Drive Natick, MA 01760-2098, 2006.