

Using Wireless Sensor Networks in Structures Health Monitoring

Assim Sagahyoon Mohamed Shashaa Omar Alsaman Jamal Abdalla
American University of Sharjah, College of Engineering, Sharjah, UAE

Abstract - The continuous structural health monitoring of civil structures provides near real-time structural conditions assessment that is critical in evaluating the short and long term conditions of a building or a structure. In this work we will report and discuss experimental results based on the use of wireless sensor units designed following the IEEE 802.15.4 standard to monitor the health of a structure and wirelessly transmit relevant data to a central repository for analysis. The structure is subjected to free vibration with initial displacement and the horizontal accelerations of floors in the structure is then recorded by the wireless sensors and transferred to the data logger.

Keywords—structural health monitoring, wireless sensor

I. INTRODUCTION

A smart civil structure can be generically defined as a structure that has an ability to sense its external environmental loading and have the ability to respond to these loads in order to enhance its performance and survivability. For the structure to be defined as a smart structure it must utilize a sensing system for monitoring its loading and a control system for limiting the damaging influence of the loading. Therefore, monitoring of civil structures holds promise as a way to provide critical information for conditions assessment. This information can, for example, be used in allocation of emergency response resources after earthquakes and for identification of apparent damage in structures that are experiencing long term deterioration. The benefits of installing a monitoring system in a structure are multiple, including the ability to assess the health of the structure over its life span and the ability to predict the effect of failures due to fatigue and corrosion. Worldwide, the installation of structural monitoring systems has become increasingly popular. In California, 61 long-span bridges have been instrumented with a total of 900 sensing channels [1,8,9]. In Europe, fiber optic strain gages have been used to monitor structural loads and long term deflection of concrete bridges [2]. In Asia, many large bridges were built with health monitoring capabilities [3]. Recently, in Athens, the Rion-Antirion bridge was completed with about 300 sensors spread along the structure [4].

Most of the current monitoring systems are characterized by having a set of sensors that are connected to a

centralized data acquisition system through cables. The sensors are *wired directly* using cables to a centralized data acquisition and processing system. The cost of these wire-based architectures is very high. The expensive nature of these types of monitoring systems is a direct result of the high installation and maintenance costs associated with system wires. Installation of the monitoring system can represent up to 25% of the total system cost with *over 75%* of the installation time focused solely on the installation of the system wires [5]. In response to this limitation, researchers are exploring the utilization of smart wireless sensor units [5-7] in an effort to develop low cost alternatives to traditional and expensive monitoring approaches. The use of sensor units that can communicate wirelessly eliminates the need for massive wiring thereby drastically reducing the cost of installation and maintenance of monitoring systems. In [7] the authors reported the design of a wireless sensor unit that is based on the Motorola 68HC11 microcontroller. In [6], the authors developed a wireless sensor unit based on the Atmel AVR RISC microcontroller. Some of the common limitations in the two designs include high power consumption (the units are battery operated), microcontrollers memories are volatile in nature, hence, unexpected power loss implies that the unit has to be removed from the field or structure to a lab setting where the program can be downloaded again. The paper is organized as follows: in section II we present an overview of the proposed system architecture. The communication aspects and the communication modes between the sensors is discussed in section III. The experimental setup and discussion of the results is included in section IV. The paper is concluded in section V.

II. System architecture

The system is based on a star network of wireless sensor boards that have sensors continuously measuring the health status of the building structure. Fig 1 shows a high level diagram for the proposed system architecture.

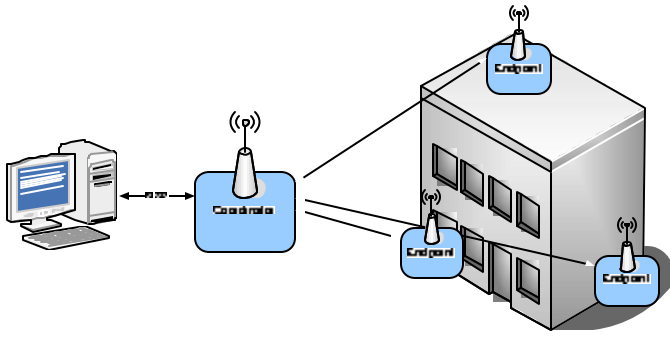

Figure 1 - System Architecture

The sensors task is to monitor the behavior of the structure during natural excitation (e.g. earthquake, strong winds, live loading). The sensory system of the endpoint units collects measurements that are reported to the coordinator unit or master. The coordinator stores and transmits the data to central data repository or database for analysis by structural engineers. All of these activities are conducted wirelessly using the IEEE 802.15.4 standard [10].

The coordinator manages the created Personal Area Network (PAN), collects that data from the endpoints, and updates the data to the computer connected to it. A computer is connected to the coordinator unit using RS232 to update the data logs.

In the context of IEEE 802.15.4, a device that can establish and maintain a PAN is called a Full Function Device (FFD), and device that can connect to a PAN but cannot establish one by its own is called a Reduced Function Device (RFD). In the system, the coordinator is a FFD, and endpoints are the RFD.

II. COMMUNICATION

A. The IEEE 802.15.4 standard

As indicated earlier, The system is based on IEEE 802.15.4 standard. It is a low data rate solution with multi-month to multi-year battery life and very low complexity. It is operating in an unlicensed, international frequency band. Potential applications are sensors, interactive toys, smart badges, remote controls, and home automation”[10]. The protocol provides a data rate of 250 kbps, 40 kbps, and 20 kbps, and it operates in 2.4GHz ISM band, 915MHz band, and 868MHz band. With its low power consumption, the standard provides an appealing solution for long term monitoring systems.

B. Network Topology

The proposed system in this work was built using a star topology network configuration. This topology was chosen because all endpoint units report to the coordinator unit of the system, and there is no communication happening between the endpoint units. Figure 2 [10], shows a typical star topology configuration, where all devices communicate through a central unit, in our case it’s the coordinator unit.

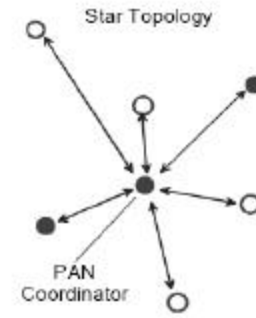

Figure 2 – Star Topology

C. Network Development

The systems starts with a single coordinator unit (FFD) that takes care of instantiating a basic PAN, and waits for new nodes to join the network. When an endpoint unit (RFD) is started, it discovers the PAN network and then tries to join it by synchronizing with the coordinator. If the endpoint is eligible to join the PAN, the coordinator adds it to the network. Now, every node that is added to the network will be beacons by the coordinator, and will read the data from the sensors and send them back to the coordinator. Figure 3, shows the flow at which the coordinator asks the network devices for data using beacon-based communication[11].

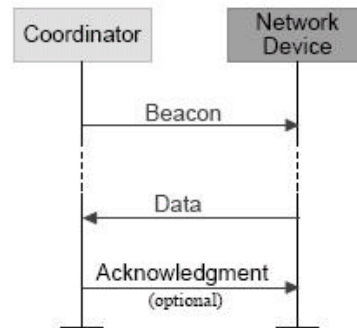

Figure 3 - Beacon Based Data Request

Using beacon-based data requests allows the coordinator to be the main controller of system by specifying how often the endpoints send their data. An alternative to this approach, is to let the endpoints send their data arbitrary, which also makes sense in cases like an earth quake where more data per second need to be collected. And in such case, the endpoint can adjust it’s reading rate to provide more continues data.

D. Datagram

Besides the data frame used by IEEE 802.15.4 protocol, we developed a simple data frame to communicate sensor data sent and received between endpoints and the coordinator. Figure 4 shows a datagram representing the frame.

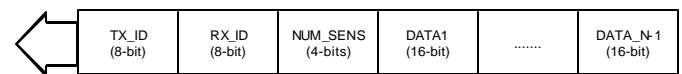

Figure 4 – Datagram

The data gram starts with TX_ID which is a unique ID of the sender node. RX_ID is the identifier of the node which this message is sent to which is a coordinator in this implementation. NUM_SENS is a number indicating the number of sensors the sender is reading and transmitting its corresponding data. DATA is a placeholder for the data read from each sensor. Using this datagram, the system can be extended to read from more sensors of a maximum of $2^4 = 16$ sensors.

IV. Experimental Setup

The end units and the coordinator contain a low-power wireless, RISC-based, IEEE802.15.4 compliant microcontroller [11]. The units contain 2.4Ghz IEEE802.15.4 transceiver, 64 KB of ROM and 6 KB of RAM, provide a versatile and low cost solution for wireless sensor networking applications. In this work, the only sensor interfaced to the units is the ADXL203 dual axis accelerometer. This is a MEMS of dimensions 5mm x5mm x 2mm. The ADXL203 is capable of measuring both positive and negative acceleration with a full scale range of +/-1.7g.

Figure 6 shows a four-story model of a building which is used as a test bed. The wireless sensor was mounted on the top floor to measure the horizontal acceleration of this floor. The four-story building model is then subjected to free vibration with initial displacement similar in shape to the first and second modes of vibration of the structure as depicted in Figure 5. The horizontal accelerations of the top floor in two directions are then recorded by the wireless sensor and transmitted to the coordinator unit. Figure 7 shows the acceleration time-history of the top floor for the two initial displacement modes. As a result, floor velocity response history and floor displacement response history can be computed and the corresponding internal forces and stresses in the building elements can be assessed. This result will give insight of the dynamic behavior of the building model.

III. CONCLUSIONS

An experimental structures health monitoring platform based on the use of wireless technology has been presented in this paper. The wireless sensors can be mounted in real life landmark structures such as long-span bridges, high-rise buildings and large dams to monitor their response and measure their performance due to large external loads such as wind and earthquakes or vehicles in case of bridges.

Future work includes the calibration of the sensors using a shake table that can be subjected to known dynamic load and the response of the wireless sensor will then be gauged with that of wired accelerometers attached to the shake table. Additional field testing on selected sites is also planned.

REFERENCES

- [1] Hipley, P. "CALTRANS: current state-of-practice", Proceedings of Instrumental Systems for Diagnostics of Seismic Response of Bridges and Dams, Consortium of Organizations for Strong-Motion Observation Systems, CA, 2001
- [2] Inaudi, D., and Vurpillot, S., "Monitoring of concrete bridges with long-gage fiber optic sensors", Journal of Intelligent Material Systems & Structures, 10(4), 1999
- [3] Tamura, K. "Instrument Systems of major bridges in Japan", Proceedings of Instrumental Systems for Diagnostics of Seismic Response of Bridges and Dams, Consortium of Organizations for Strong-Motion Observation Systems, CA, 2001
- [4] IEEE Spectrum, "Special Report: Sensor Nation", July 2004
- [5] Lynch, J. P; et al, "Design of Wireless Sensor Units with Embedded Statistical Time-Series Damage Detection Algorithms for Structural Health Monitoring," Caltrans/UCSD Workshop on Structural Health Monitoring and Diagnostics of Bridge Infrastructure, CA, 2003.
- [6] Lynch, J. P. et al, "Embedment of Structural Monitoring Algorithms in a Wireless Sensing Unit. Structural Engineering and Mechanics 15(3), 2003
- [7] Lynch, J. P. et al, "Laboratory and Field Validation of a Wireless Sensing Unit Design for Structural Monitoring," Proceedings of US-Korea Workshop on Smart Structural Systems, Pusan, Korea, 2002.
- [8] Haroun, M. A. et al, "Comparative Testing of Full and Half Scale Models of Bridge Pier Walls", Proceedings of XVI International Model Analysis Conference, CA, 1998
- [9] Atkin A.E. et al, "Field Laboratory for Modal Analysis and Condition Assessment of Highway Bridges", Proceedings of International Modal Analysis Conference XV, 1997
- [10] <http://www.ieee802.org/15/pub/TG4.html>
- [11] www.jennic.com

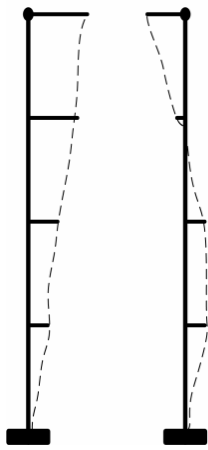

Figure 5- Vibration Modes

Endpoint Sensor



Coordinator Unit

Figure 6 – Experimental Test bed

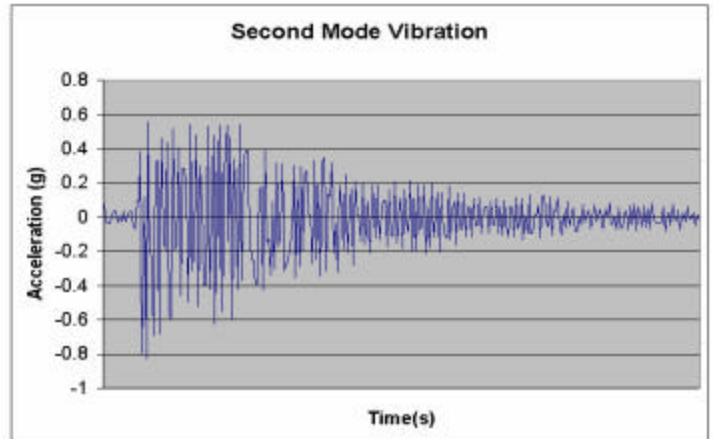
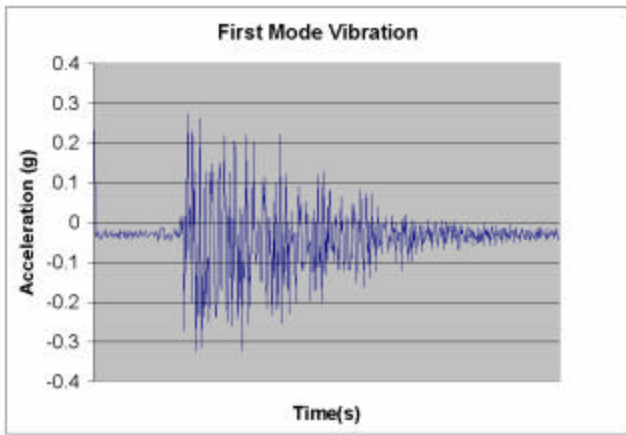

Figure 7. Acceleration/Time History for the two Modes