

# Chapter 6

## PASSBAND DATA TRANSMISSION

Dr. Samir Alghadhban

1

## Content

- *Different methods of digital modulation, namely, phase-shift keying, quadrature- amplitude modulation, and frequency-shift keying, and their individual variants.*
- *Coherent detection of modulated signals in additive white Gaussian noise, which requires the receiver to be synchronized to the transmitter with respect to both carrier phase and bit timing.*
- *Noncoherent detection of modulated signals in additive white Gaussian noise, disregarding phase information in the received signal*

2

## 6.1 Introduction

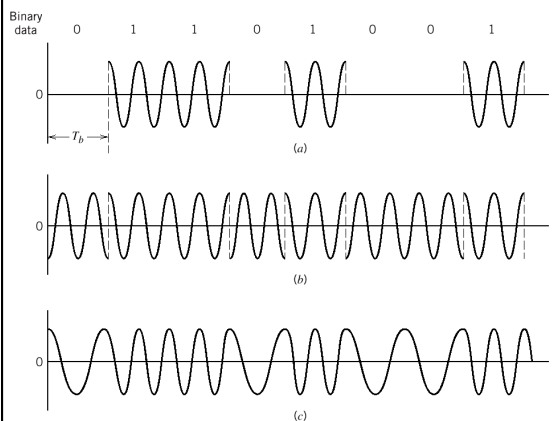

- (a) Amplitude-shift keying.
- (b) Phase-shift keying.
- (c) Frequency-shift keying

3

## Performance Metrics

- PROBABILITY OF ERROR
- POWER SPECTRA
  - Baseband power spectral density
- BANDWIDTH EFFICIENCY
  - *The ratio of the data rate in bits per second to the effectively utilized channel bandwidth*

$$\rho = \frac{R_b}{B} \text{ bits/s/Hz}$$

4

## Power Spectra

$$\begin{aligned} s(t) &= s_I(t) \cos(2\pi f_c t) - s_Q(t) \sin(2\pi f_c t) \\ &= \operatorname{Re}[\tilde{s}(t) \exp(j2\pi f_c t)] \end{aligned}$$

Complex envelope  $\tilde{s}(t) = s_I(t) + js_Q(t)$  Baseband equivalent signal for the bandpass signal  $s(t)$

$$\exp(j2\pi f_c t) = \cos(2\pi f_c t) + j \sin(2\pi f_c t)$$

Let  $S_B(f)$  be the baseband power spectral density, then

$$S_S(f) = \frac{1}{4} [S_B(f - f_c) + S_B(f + f_c)]$$

5

## 6.2 Passband Transmission Model

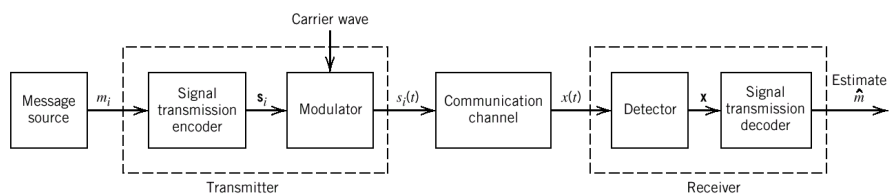

6

## 6.3 Coherent Phase-Shift Keying

$$s_1(t) = \sqrt{\frac{2E_b}{T_b}} \cos(2\pi f_c t)$$

$$s_2(t) = \sqrt{\frac{2E_b}{T_b}} \cos(2\pi f_c t + \pi) = -\sqrt{\frac{2E_b}{T_b}} \cos(2\pi f_c t)$$

$$\phi_1(t) = \sqrt{\frac{2}{T_b}} \cos(2\pi f_c t), \quad 0 \leq t < T_b$$

$$s_1(t) = \sqrt{E_b} \phi_1(t), \quad 0 \leq t < T_b$$

$$s_2(t) = -\sqrt{E_b} \phi_1(t), \quad 0 \leq t < T_b$$

$$s_{11} = \int_0^{T_b} s_1(t) \phi_1(t) dt = +\sqrt{E_b}$$

$$s_{21} = \int_0^{T_b} s_2(t) \phi_1(t) dt = -\sqrt{E_b}$$

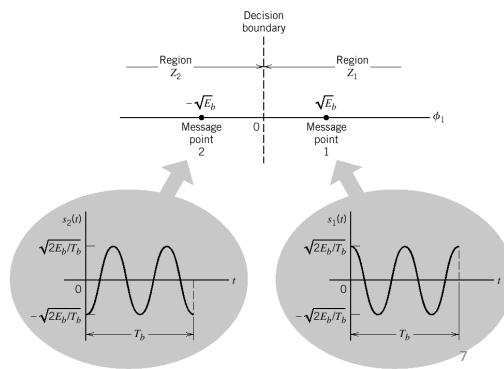

## Error Probability of BPSK

Using pairwise error probability relation as discussed in chapter 5

$$\Pr\{s_i \rightarrow s_k\} = \frac{1}{2} \operatorname{erfc} \left( \frac{\|s_i - s_k\|}{2\sqrt{N_0}} \right) = Q \left( \frac{\|s_i - s_k\|}{\sqrt{2N_0}} \right)$$

Since the Euclidean Distance between the two symbols is

$$\|s_1 - s_2\| = d_{12} = 2\sqrt{E_b}$$

$$P_e = \frac{1}{2} \operatorname{erfc} \left( \sqrt{\frac{E_b}{N_0}} \right)$$

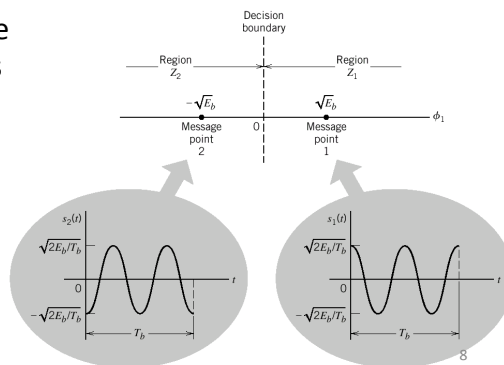

## Error Probability of BPSK Detailed Analysis

$$f_{x_1}(x_1|0) = \frac{1}{\sqrt{\pi N_0}} \exp\left[-\frac{1}{N_0} (x_1 - s_{21})^2\right]$$

$$= \frac{1}{\sqrt{\pi N_0}} \exp\left[-\frac{1}{N_0} (x_1 + \sqrt{E_b})^2\right]$$

$$P_e = \frac{1}{2} \operatorname{erfc}\left(\sqrt{\frac{E_b}{N_0}}\right)$$

$$p_{10} = \int_0^{\infty} f_{x_1}(x_1|0) dx_1$$

$$= \frac{1}{\sqrt{\pi N_0}} \int_0^{\infty} \exp\left[-\frac{1}{N_0} (x_1 + \sqrt{E_b})^2\right] dx_1$$

$$z = \frac{1}{\sqrt{N_0}} (x_1 + \sqrt{E_b})$$

$$p_{10} = \frac{1}{\sqrt{\pi}} \int_{\sqrt{E_b/N_0}}^{\infty} \exp(-z^2) dz$$

$$= \frac{1}{2} \operatorname{erfc}\left(\sqrt{\frac{E_b}{N_0}}\right)$$

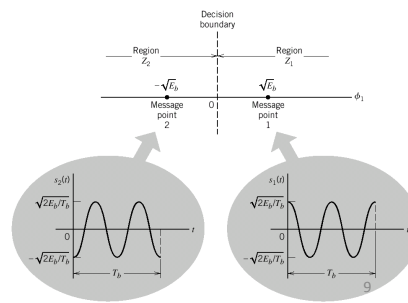

## Generation and Detection of Coherent BPSK Signals

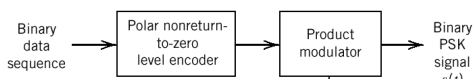

$$\phi_1(t) = \sqrt{\frac{2}{T_b}} \cos(2\pi f_c t)$$

(a)

(a) binary PSK transmitter

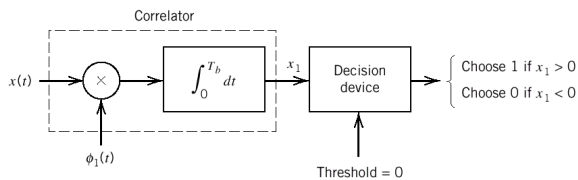

(b)

(b) coherent binary PSK receiver.

## Power Spectra of BPSK Signals

symbol shaping function 
$$g(t) = \begin{cases} \sqrt{\frac{2E_b}{T_b}}, & 0 \leq t \leq T_b \\ 0, & \text{otherwise} \end{cases}$$

The power spectral density of a random binary wave so described is equal to the energy spectral density of the symbol shaping function divided by the symbol duration. The energy spectral density of a Fourier transformable signal  $g(t)$  is defined as the squared magnitude of the signal's Fourier transform. (see example 1.6 in textbook)

$$S_x(f) = \frac{\mathcal{E}_g(f)}{T}$$

$$S_B(f) = \frac{2E_b \sin^2(\pi T_b f)}{(\pi T_b f)^2} = 2E_b \operatorname{sinc}^2(T_b f)$$

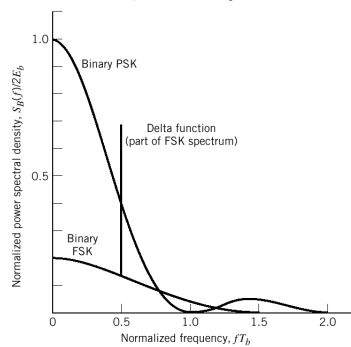

11

## QUADRIPHASE-SHIFT KEYING (QPSK)

$$s_i(t) = \begin{cases} \sqrt{\frac{2E}{T}} \cos\left[2\pi f_c t + (2i - 1) \frac{\pi}{4}\right], \\ 0, \end{cases} \quad s_i = \begin{bmatrix} \sqrt{E} \cos\left((2i - 1) \frac{\pi}{4}\right) \\ -\sqrt{E} \sin\left((2i - 1) \frac{\pi}{4}\right) \end{bmatrix}, \quad i = 1, 2, 3, 4$$

$$s_i(t) = \sqrt{\frac{2E}{T}} \cos\left[(2i - 1) \frac{\pi}{4}\right] \cos(2\pi f_c t) - \sqrt{\frac{2E}{T}} \sin\left[(2i - 1) \frac{\pi}{4}\right] \sin(2\pi f_c t)$$

$$\phi_1(t) = \sqrt{\frac{2}{T}} \cos(2\pi f_c t), \quad 0 \leq t \leq T$$

$$\phi_2(t) = \sqrt{\frac{2}{T}} \sin(2\pi f_c t), \quad 0 \leq t \leq T$$

**TABLE 6.1 Signal-space characterization of QPSK**

Gray-encoded Input Dibit	Phase of QPSK Signal (radians)	Coordinates of Message Points	
		$s_{11}$	$s_{12}$
10	$\pi/4$	$+\sqrt{E/2}$	$-\sqrt{E/2}$
00	$3\pi/4$	$-\sqrt{E/2}$	$-\sqrt{E/2}$
01	$5\pi/4$	$-\sqrt{E/2}$	$+\sqrt{E/2}$
11	$7\pi/4$	$+\sqrt{E/2}$	$+\sqrt{E/2}$

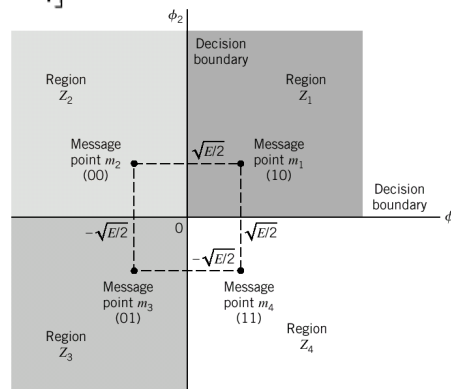

## Example of QPSK

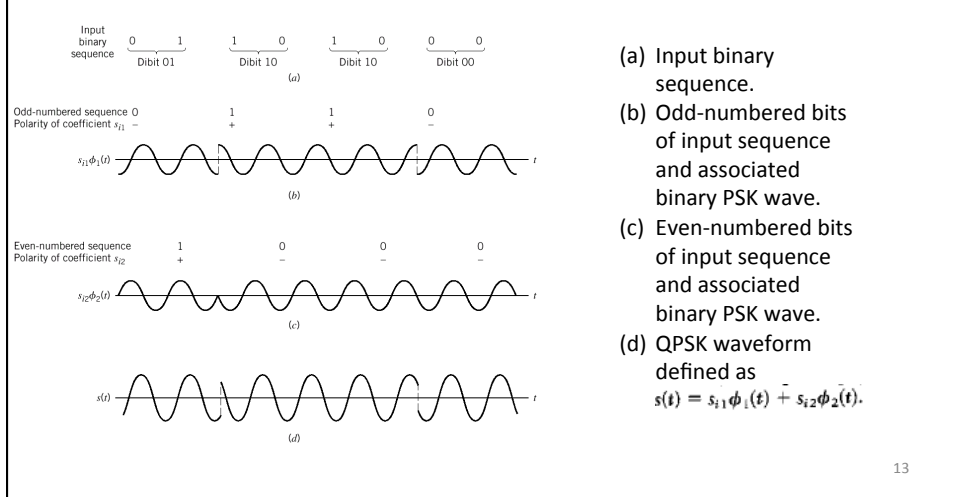

13

## Error Probability of QPSK

Using the union bound as described in chapter 5

$$P_e \leq \text{erfc}\left(\sqrt{\frac{E}{2N_0}}\right) + \frac{1}{2} \text{erfc}\left(\sqrt{\frac{E}{N_0}}\right)$$

By reducing the overlap region, a tighter bound is

$$P_e \leq \text{erfc}\left(\sqrt{\frac{E}{2N_0}}\right)$$

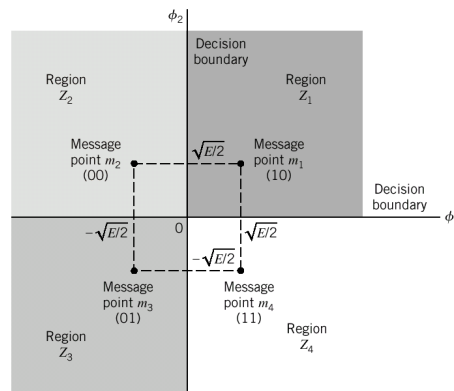

## Exact Error Analysis

- To calculate the average probability of symbol error, we note from Equation that a coherent QPSK system is in fact equivalent to two coherent binary PSK systems working in parallel and using two carriers that are in phase quadrature.
- These two binary PSK systems may be characterized as follows:
  - The signal energy per bit is  $E/2$ .
  - The noise spectral density is  $N_0/2$ .
- Thus, the average probability of bit error in *each* channel of the coherent QPSK system is

$$P' = \frac{1}{2} \operatorname{erfc}\left(\sqrt{\frac{E/2}{N_0}}\right)$$

$$= \frac{1}{2} \operatorname{erfc}\left(\sqrt{\frac{E}{2N_0}}\right)$$

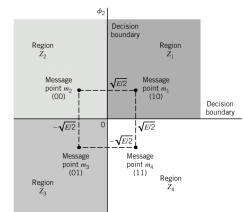

## Exact Error Analysis

- Since the bit errors in the in-phase and quadrature channels of the coherent QPSK system are statistically independent.
- Then, the *average probability of a correct decision* resulting from the combined action of the two channels working together is

$$P_c = (1 - P')^2$$

$$= \left[1 - \frac{1}{2} \operatorname{erfc}\left(\sqrt{\frac{E}{2N_0}}\right)\right]^2$$

$$= 1 - \operatorname{erfc}\left(\sqrt{\frac{E}{2N_0}}\right) + \frac{1}{4} \operatorname{erfc}^2\left(\sqrt{\frac{E}{2N_0}}\right)$$

- The average probability of symbol error for coherent QPSK is therefore

$$P_e = 1 - P_c$$

$$= \operatorname{erfc}\left(\sqrt{\frac{E}{2N_0}}\right) - \frac{1}{4} \operatorname{erfc}^2\left(\sqrt{\frac{E}{2N_0}}\right)$$

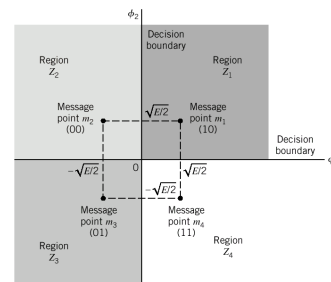



## Error Analysis

$$P_e = 1 - P_c$$

$$= \operatorname{erfc}\left(\sqrt{\frac{E}{2N_0}}\right) - \frac{1}{4} \operatorname{erfc}^2\left(\sqrt{\frac{E}{2N_0}}\right)$$

- we may ignore the quadratic term on the right-hand side

$$P_e \approx \operatorname{erfc}\left(\sqrt{\frac{E}{2N_0}}\right) \longrightarrow \text{Equals to the tight bound}$$

17

## QPSK vs BPSK

- In a QPSK system, we note that since there are two bits per symbol, the transmitted signal energy per symbol is twice the signal energy per bit  $E=2E_b$
- Thus expressing the average probability of symbol error in terms of the ratio  $E_b/N_0$ , we may write

$$P_e \approx \operatorname{erfc}\left(\sqrt{\frac{E_b}{N_0}}\right)$$

- With Gray encoding used for the incoming symbols, we find in chapter 5 that the *bit error rate* of QPSK is

$$\text{BER} = \frac{1}{2} \operatorname{erfc}\left(\sqrt{\frac{E_b}{N_0}}\right) \longrightarrow \text{Same as BPSK}$$

18

## Generation and Detection of Coherent QPSK Signals

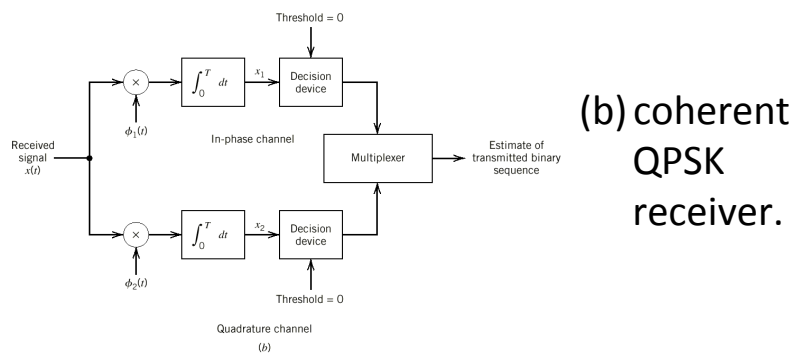
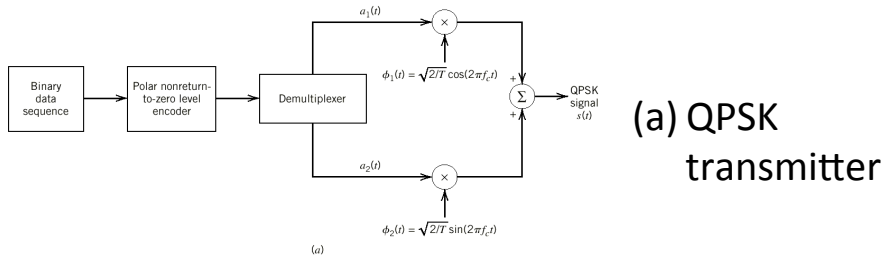

19

## Power Spectra of QPSK Signals

the symbol shaping function 
$$g(t) = \begin{cases} \sqrt{\frac{E}{T}}, & 0 \leq t \leq T \\ 0, & \text{otherwise} \end{cases}$$

Hence, the in-phase and quadrature components have a common power spectral density, namely,  $E \text{sinc}^2(T/f)$

The in-phase and quadrature components are statistically independent. Accordingly, the baseband power spectral density of the QPSK signal equals the sum of the individual power spectral densities of the in-phase and quadrature components

$$S_B(f) = 2E \text{sinc}^2(Tf) = 4E_b \text{sinc}^2(2T_b f)$$

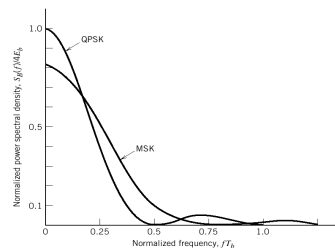

## Power Spectra QPSK vs BPSK

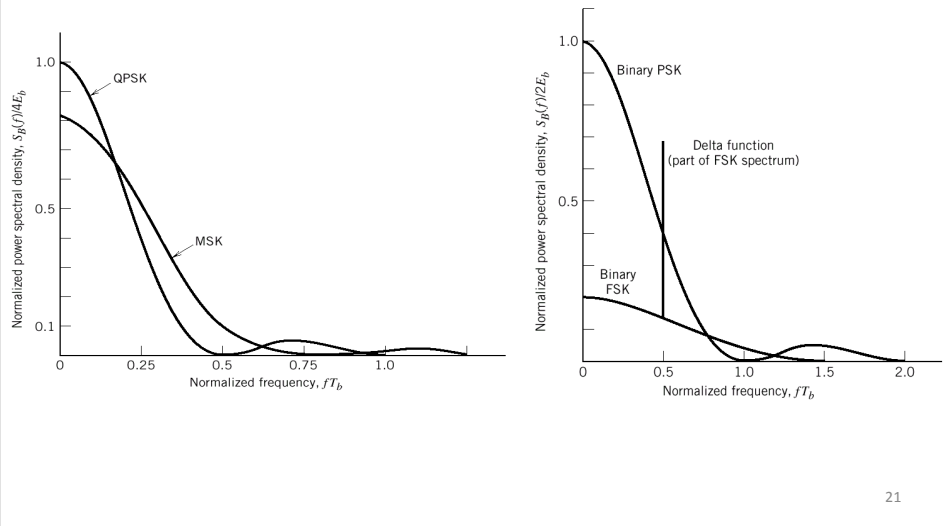

21

## M-PSK

$$s_i(t) = \sqrt{\frac{2E}{T}} \cos\left(2\pi f_c t + \frac{2\pi}{M}(i-1)\right), \quad i = 1, 2, \dots, M$$

$$\phi_1(t) = \sqrt{\frac{2}{T}} \cos(2\pi f_c t), \quad 0 \leq t \leq T$$

$$\phi_2(t) = \sqrt{\frac{2}{T}} \sin(2\pi f_c t), \quad 0 \leq t \leq T$$

$$d_{12} = d_{18} = 2\sqrt{E} \sin\left(\frac{\pi}{M}\right)$$

$$P_e \approx \text{erfc}\left(\sqrt{\frac{E}{N_0}} \sin\left(\frac{\pi}{M}\right)\right)$$

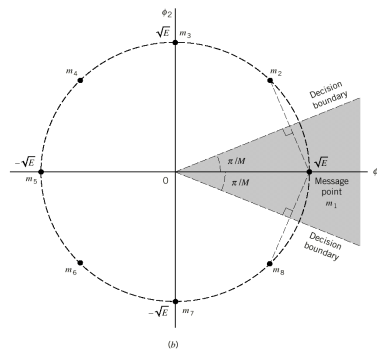
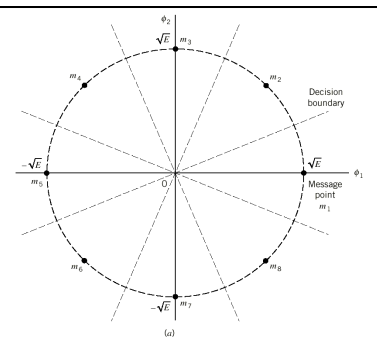

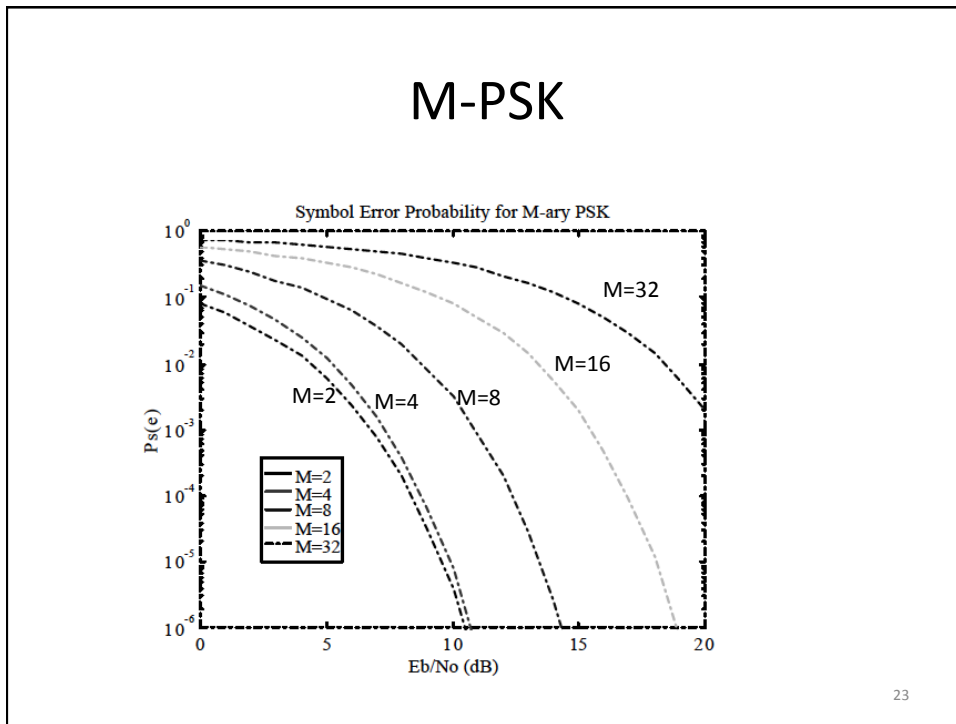

## Power Spectral of M-PSK

- The symbol duration of M-ary PSK is defined by  $T = T_b \log_2 M$  where  $T_b$  is the bit duration.
- Proceeding in a manner similar to that described for a QPSK signal, we may show that the baseband power spectral density of an M-ary PSK signal is given by

$$S_B(f) = 2E \operatorname{sinc}^2(Tf)$$

$$= 2E_b \log_2 M \operatorname{sinc}^2(T_b f \log_2 M)$$

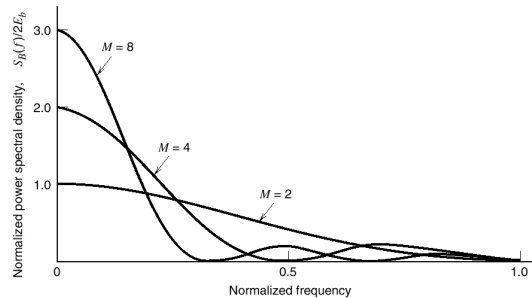

## BANDWIDTH EFFICIENCY OF M-ARY PSK SIGNALS

- The power spectra of M-ary PSK signals possess a *main lobe* bounded by well-defined *spectral nulls* (i.e., frequencies at which the power spectral density is zero).
- Accordingly the spectral width of the main lobe provides a simple and popular measure for the band width of M-ary PSK signals.
- This definition is referred to as the *null-to-null bandwidth*.
- With the null-to-null bandwidth encompassing the main lobe of the power spectrum of an M-ary signal, we find that it contains most of the signal power.

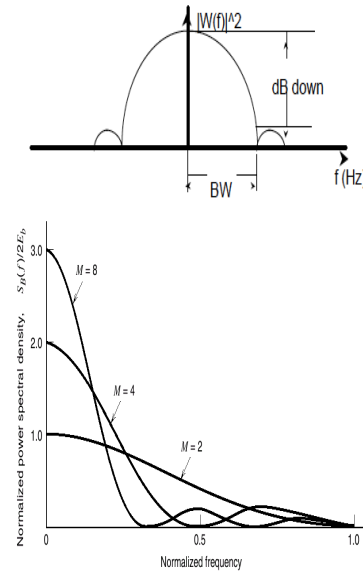

## BANDWIDTH EFFICIENCY OF M-ARY PSK SIGNALS

- The channel bandwidth required to pass M-ary PSK signals (more precisely, the main spectral lobe of M-ary signals)

$$B = \frac{2}{T}$$

- Where T is the symbol duration. Recall that  $T = T_b \log_2 M$
- Since the bit rate  $R_b = 1/T_b$ , then we have

$$B = \frac{2R_b}{\log_2 M}$$

- Therefore, the bandwidth efficiency of M-ary PSK signals will be:

$$\begin{aligned} \rho &= \frac{R_b}{B} \\ &= \frac{\log_2 M}{2} \end{aligned}$$

## BANDWIDTH EFFICIENCY OF M-ARY PSK SIGNALS

$$\begin{aligned}\rho &= \frac{R_b}{B} \\ &= \frac{\log_2 M}{2}\end{aligned}$$

**TABLE 6.4** *Bandwidth efficiency of M-ary PSK signals*

M	2	4	8	16	32	64
$\rho$ (bits/s/Hz)	0.5	1	1.5	2	2.5	3

27

## 6.5 Coherent Frequency-Shift Keying

### BINARY FSK

$$s_i(t) = \begin{cases} \sqrt{\frac{2E_b}{T_b}} \cos(2\pi f_i t), & 0 \leq t \leq T_b \\ 0, & \text{elsewhere} \end{cases}$$

$$f_i = \frac{n_c + i}{T_b} \quad \text{for some fixed integer } n_c \text{ and } i = 1, 2$$

we observe directly that the signals  $s_1(t)$  and  $s_2(t)$  are orthogonal, but not normalized to have unit energy. We therefore deduce that the most useful form for the set of orthonormal basis functions is

$$\phi_i(t) = \begin{cases} \sqrt{\frac{2}{T_b}} \cos(2\pi f_i t), & 0 \leq t \leq T_b \\ 0, & \text{elsewhere} \end{cases}$$

28

## 6.5 Coherent Frequency-Shift Keying

### BINARY FSK

$$s_{ij} = \int_0^{T_b} s_i(t) \phi_j(t) dt$$

$$= \int_0^{T_b} \sqrt{\frac{2E_b}{T_b}} \cos(2\pi f_i t) \sqrt{\frac{2}{T_b}} \cos(2\pi f_j t) dt$$

$$= \begin{cases} \sqrt{E_b}, & i = j \\ 0, & i \neq j \end{cases}$$

$$s_1 = \begin{bmatrix} \sqrt{E_b} \\ 0 \end{bmatrix} \quad s_2 = \begin{bmatrix} 0 \\ \sqrt{E_b} \end{bmatrix}$$

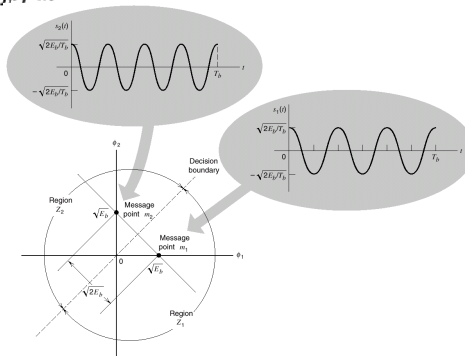

## 6.5 Pairwise Error Probability: Binary FSK

- The signal constellation for binary FSK is:

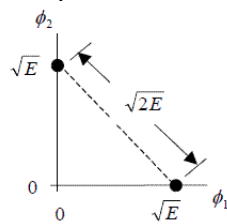

E is the average signal Energy

The Euclidean distance between the two signals is:

$$d_{12} = \|s_1 - s_2\| = \sqrt{2E_b}$$

$$\Pr\{s_i \rightarrow s_j\} = Q\left(\sqrt{\frac{E_b}{N_0}}\right) = \frac{1}{2} \operatorname{erfc}\left(\sqrt{\frac{E_b}{2N_0}}\right)$$

## 6.5 Block Diagram of Binary FSK

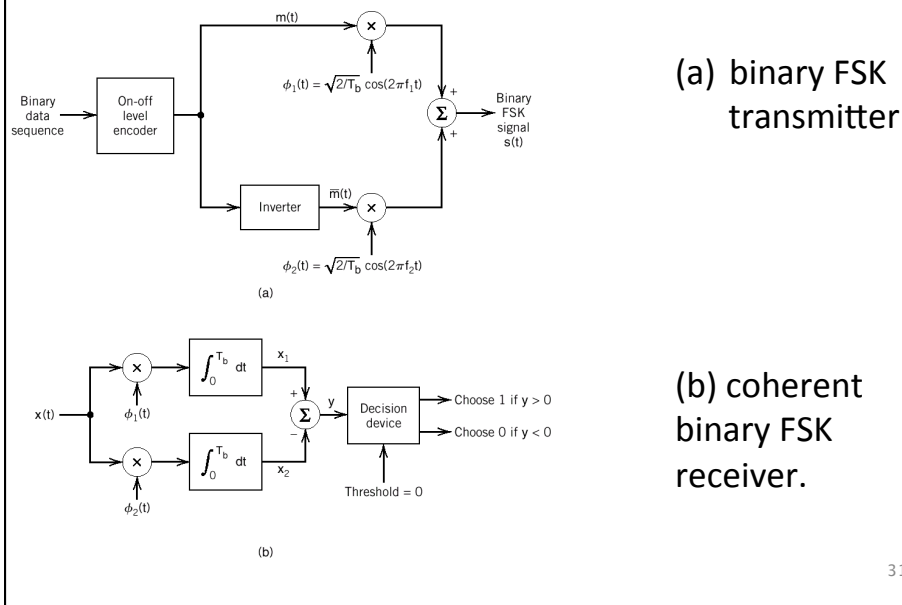

31

## 6.5 Power Spectra of Binary FSK Signals

Consider the case of Sunde's FSK, for which the two transmitted frequencies  $f_1$  and  $f_2$  differ by an amount equal to the bit rate  $1/T_b$ , and their arithmetic mean equals the nominal carrier frequency  $f_c$ ; phase continuity is always maintained, including inter-bit switching times.

$$s(t) = \sqrt{\frac{2E_b}{T_b}} \cos\left(2\pi f_c t \pm \frac{\pi t}{T_b}\right), \quad 0 \leq t \leq T_b$$

$$\begin{aligned} s(t) &= \sqrt{\frac{2E_b}{T_b}} \cos\left(\pm \frac{\pi t}{T_b}\right) \cos(2\pi f_c t) - \sqrt{\frac{2E_b}{T_b}} \sin\left(\pm \frac{\pi t}{T_b}\right) \sin(2\pi f_c t) \\ &= \sqrt{\frac{2E_b}{T_b}} \cos\left(\frac{\pi t}{T_b}\right) \cos(2\pi f_c t) \mp \sqrt{\frac{2E_b}{T_b}} \sin\left(\frac{\pi t}{T_b}\right) \sin(2\pi f_c t) \end{aligned}$$

32



## 6.5 Power Spectra of Binary FSK Signals

$$\begin{aligned} s(t) &= \sqrt{\frac{2E_b}{T_b}} \cos\left(\pm \frac{\pi t}{T_b}\right) \cos(2\pi f_c t) - \sqrt{\frac{2E_b}{T_b}} \sin\left(\pm \frac{\pi t}{T_b}\right) \sin(2\pi f_c t) \\ &= \sqrt{\frac{2E_b}{T_b}} \cos\left(\frac{\pi t}{T_b}\right) \cos(2\pi f_c t) \mp \sqrt{\frac{2E_b}{T_b}} \sin\left(\frac{\pi t}{T_b}\right) \sin(2\pi f_c t) \end{aligned}$$

1. The in-phase component is completely independent of the input binary wave. It equals  $\sqrt{2E_b/T_b} \cos(\pi t/T_b)$  for all values of time  $t$ . The power spectral density of this component therefore consists of two delta functions, weighted by the fact  $E_b/2T_b$ , and occurring at  $f = \pm 1/2T_b$ .
2. The quadrature component is directly related to the input binary wave. During the signaling interval  $0 \leq t \leq T_b$ , it equals  $-g(t)$  when we have symbol 1, and  $+g(t)$  when we have symbol 0. The symbol shaping function  $g(t)$  is defined by

$$g(t) = \begin{cases} \sqrt{\frac{2E_b}{T_b}} \sin\left(\frac{\pi t}{T_b}\right), & 0 \leq t \leq T_b \\ 0, & \text{elsewhere} \end{cases}$$

33

## 6.5 Power Spectra of Binary FSK Signals

The energy spectral density of this symbol shaping function equals

$$\Psi_g(f) = \frac{8E_b T_b \cos^2(\pi T_b f)}{\pi^2 (4T_b^2 f^2 - 1)^2}$$

The power spectral density of the quadrature component equals  $\Psi_g(f)/T_b$ . It is also apparent that the in-phase and quadrature components of the binary FSK signal are independent of each other. Accordingly, the baseband power spectral density of Sunde's FSK signal equals the sum of the power spectral densities of these two components, as shown by :

$$S_B(f) = \frac{E_b}{2T_b} \left[ \delta\left(f - \frac{1}{2T_b}\right) + \delta\left(f + \frac{1}{2T_b}\right) \right] + \frac{8E_b \cos^2(\pi T_b f)}{\pi^2 (4T_b^2 f^2 - 1)^2}$$

34

## 6.5 Power Spectra of Binary FSK Signals

$$S_B(f) = \frac{E_b}{2T_b} \left[ \delta\left(f - \frac{1}{2T_b}\right) + \delta\left(f + \frac{1}{2T_b}\right) \right] + \frac{8E_b \cos^2(\pi T_b f)}{\pi^2(4T_b^2 f^2 - 1)^2}$$

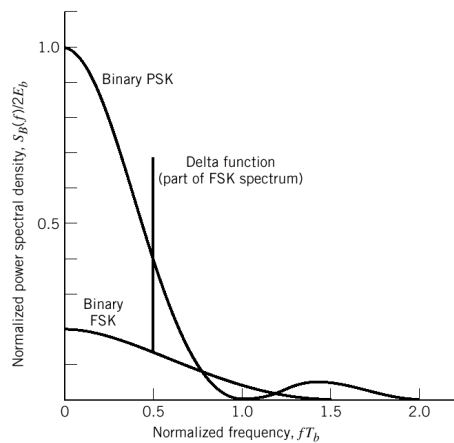

For Binary PSK

$$\begin{aligned} S_B(f) &= \frac{2E_b \sin^2(\pi T_b f)}{(\pi T_b f)^2} \\ &= 2E_b \operatorname{sinc}^2(T_b f) \end{aligned}$$

35

## 6.5 M-ARY FSK

$$s_i(t) = \sqrt{\frac{2E}{T}} \cos\left[\frac{\pi}{T}(n_c + i)t\right], \quad 0 \leq t \leq T$$

where  $i = 1, 2, \dots, M$ , and the carrier frequency  $f_c = n_c/2T$  for some fixed integer  $n_c$ . The transmitted symbols are of equal duration  $T$  and have equal energy  $E$ . Since the individual signal frequencies are separated by  $1/2T$  Hz, the signals are orthogonal; that is

$$\int_0^T s_i(t)s_j(t) dt = 0, \quad i \neq j$$

Complete orthonormal set of basis functions are :

$$\phi_i(t) = \frac{1}{\sqrt{E}} s_i(t), \quad 0 \leq t \leq T, \quad i = 1, 2, \dots, M$$

36

## 6.5 MFSK: Error Probability

Using the union bound to place an upper bound on the average probability of symbol error for M-ary FSK. Specifically, noting that the minimum distance  $d_{min}$  in M-ary FSK is  $\sqrt{2E}$

$$P_e \leq \frac{1}{2} (M - 1) \operatorname{erfc} \left( \sqrt{\frac{E}{2N_0}} \right)$$

**Power Spectra of M-ary FSK Signals**

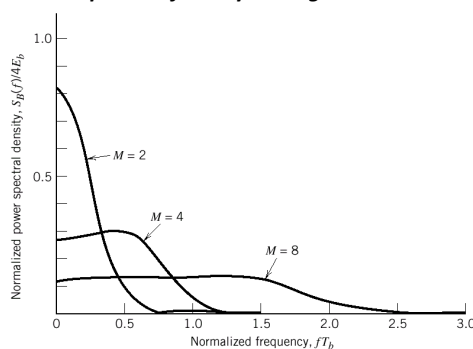

37

## 6.5 Bandwidth Efficiency of M-ary FSK Signals

When the orthogonal signals of an M-ary FSK signal are detected coherently, the adjacent signals need only be separated from each other by a frequency difference  $1/2T$  so as to maintain orthogonality. Hence, we may define the channel bandwidth required to transmit M-ary FSK signals as

$$B = \frac{M}{2T}$$

Since  $T = T_b \log_2 M$  and  $R_b = 1/T_b$

$$B = \frac{R_b M}{2 \log_2 M}$$

The bandwidth efficiency of M-ary signals is therefore  $\rho = \frac{R_b}{B}$

$$= \frac{2 \log_2 M}{M}$$

**TABLE 6.6 Bandwidth efficiency of M-ary FSK signals**

M	2	4	8	16	32	64
$\rho$ (bits/s/Hz)	1	1	0.75	0.5	0.3125	0.1875

38

## 6.8 Noncoherent Binary FSK

$$s_i(t) = \begin{cases} \sqrt{\frac{2E_b}{T_b}} \cos(2\pi f_i t), & 0 \leq t \leq T_b \\ 0, & \text{elsewhere} \end{cases}$$

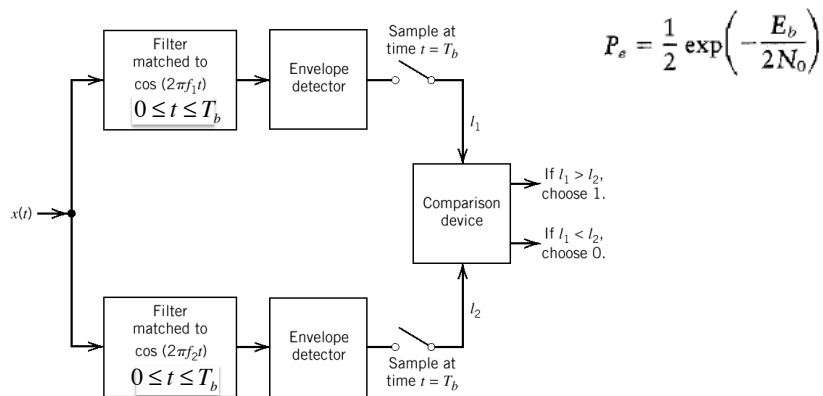

39

## 6.9 Differential Phase-Shift Keying

Differential phase-shift keying (DPSK) is the noncoherent version of PSK. It eliminates the need for a coherent reference signal at the receiver by combining two basic operations at the transmitter:

- (1) differential encoding of the input binary wave
- (2) phase-shift keying

The differential encoding process at the transmitter input starts with an arbitrary first bit, serving as reference. Let  $\{d_k\}$  denote the differentially encoded sequence with this added reference bit. We now introduce the following definitions in the generation of this sequence:

- If the incoming binary symbol  $b_k$  is 1, leave the symbol  $d_k$  unchanged with respect to the previous bit.
- If the incoming binary symbol  $b_k$  is 0, change the symbol  $d_k$  with respect to the previous bit.

**TABLE 6.7** Illustrating the generation of DPSK signal

$\{b_k\}$	1	0	0	1	0	0	1	1
$\{d_{k-1}\}$	1	1	0	1	1	0	1	1
Differentially encoded sequence $\{d_k\}$	1	1	0	1	1	0	1	1
Transmitted phase (radians)	0	0	$\pi$	0	0	$\pi$	0	0

## 6.9 Differential Phase-Shift Keying

The transmission of symbol 1 leaves the carrier phase unchanged

$$s_1(t) = \begin{cases} \sqrt{\frac{E_b}{2T_b}} \cos(2\pi f_c t), & 0 \leq t \leq T_b \\ \sqrt{\frac{E_b}{2T_b}} \cos(2\pi f_c t), & T_b \leq t \leq 2T_b \end{cases}$$

The transmission of 0 advances the carrier phase by 180 degrees

$$s_2(t) = \begin{cases} \sqrt{\frac{E_b}{2T_b}} \cos(2\pi f_c t), & 0 \leq t \leq T_b \\ \sqrt{\frac{E_b}{2T_b}} \cos(2\pi f_c t + \pi), & T_b \leq t \leq 2T_b \end{cases}$$

Bit error rate for DPSK is given by

$$P_e = \frac{1}{2} \exp\left(-\frac{E_b}{N_0}\right)$$

41

## 6.9 Differential Phase-Shift Keying

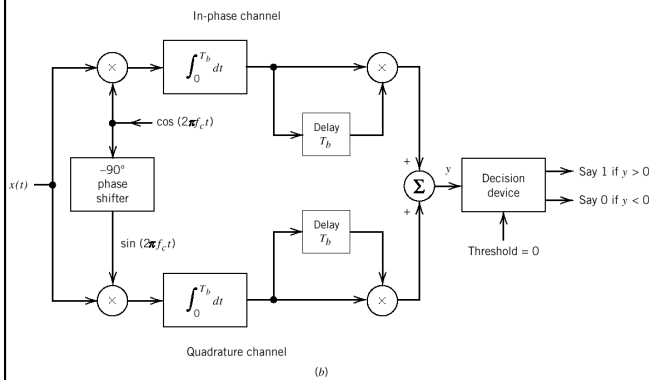
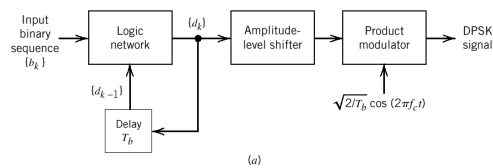

42

## 6.9 Differential Phase-Shift Keying: Receiver

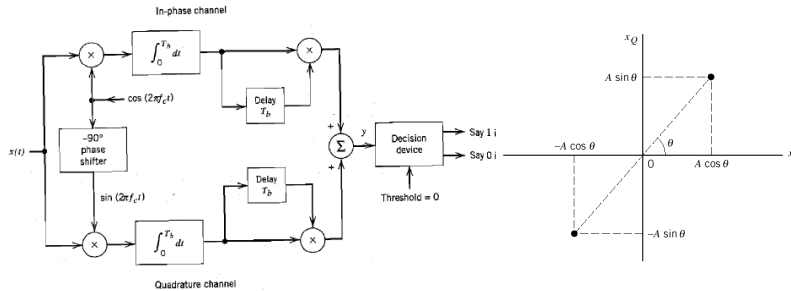

The receiver measures the coordinates  $(x_{I0}, x_{Q0})$  at time  $t = T_b$  and  $(x_{I1}, x_{Q1})$  at time  $t = 2T_b$ . The issue to be resolved is whether these two points map to the same signal point or different ones.

Recognizing that the two vectors  $\mathbf{x}_0$  and  $\mathbf{x}_1$  are pointed roughly in the same direction if their inner product is positive.

$$x_{I0}x_{I1} + x_{Q0}x_{Q1} \begin{matrix} \text{say 1} \\ \geq 0 \\ \text{say 0} \end{matrix}$$

43

## 6.4 M-ARY Quadrature Amplitude Modulation

$$s_k(t) = \sqrt{\frac{2E_0}{T}} a_k \cos(2\pi f_c t) - \sqrt{\frac{2E_0}{T}} b_k \sin(2\pi f_c t), \quad 0 \leq t \leq T$$

$$k = 0, \pm 1, \pm 2, \dots$$

Where  $E_0$  is the energy of the signal with the lowest amplitude

Let  $d_{\min}$  be the minimum distance between two points, thus  $\frac{d_{\min}}{2} = \sqrt{E_0}$

Thus, the  $i^{\text{th}}$  message  $s_i$  will be  $(a_i d_{\min} / 2, b_i d_{\min} / 2)$

The orthonormal basis functions are:

$$\phi_1(t) = \sqrt{\frac{2}{T}} \cos(2\pi f_c t), \quad 0 \leq t \leq T$$

$$\phi_2(t) = \sqrt{\frac{2}{T}} \sin(2\pi f_c t), \quad 0 \leq t \leq T$$

44

## 6.4 M-ARY Quadrature Amplitude Modulation

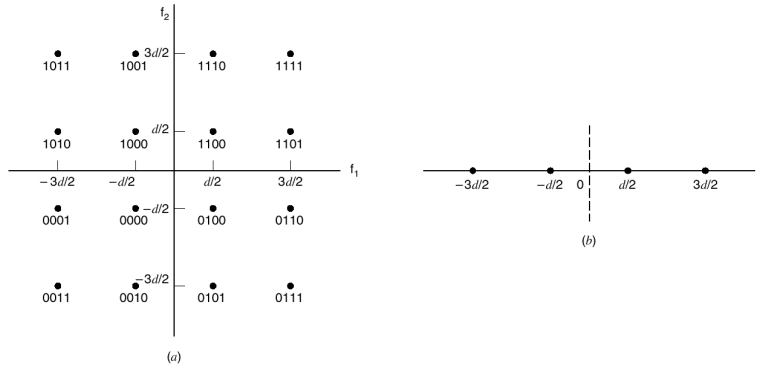

Symbol error probability for M-ary QAM is

$$P_e = 2 \left( 1 - \frac{1}{\sqrt{M}} \right) \operatorname{erfc} \left( \sqrt{\frac{E_0}{N_0}} \right)$$

45

## 6.10 Comparison

**TABLE 6.8** Summary of formulas for the bit error rate of different digital modulation schemes

Signaling Scheme	Bit Error Rate
(a) Coherent binary PSK Coherent QPSK Coherent MSK	$\frac{1}{2} \operatorname{erfc}(\sqrt{E_b/N_0})$
(b) Coherent binary FSK	$\frac{1}{4} \operatorname{erfc}(\sqrt{E_b/2N_0})$
(c) DPSK	$\frac{1}{4} \exp(-E_b/N_0)$
(d) Noncoherent binary FSK	$\frac{1}{2} \exp(-E_b/2N_0)$

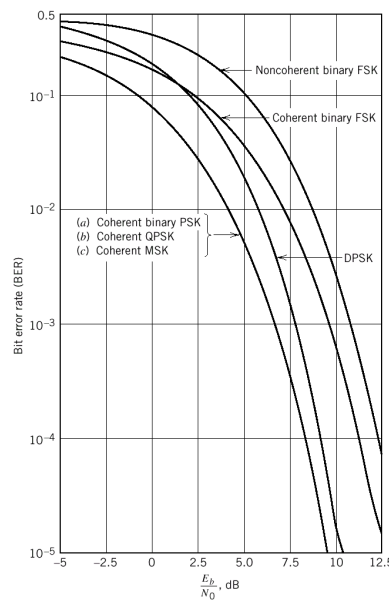

46