

Electrical Engineering Department
EE-416 Analog Filter Design
Instructor: Dr. Hussain Alzاهر
H.W.# 5

1) The circuit shown in Figure 1 is known as general impedance converter GIC which can be used to realize variety of different input impedances particularly active inductance. Assuming ideal op-amps, find the circuit input impedance V_L/I_1 .

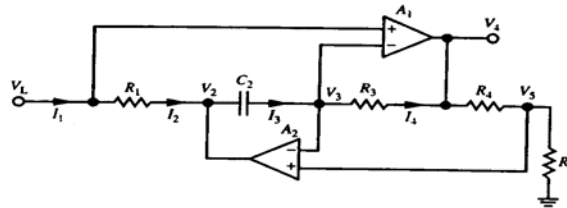

Figure 1

2) A bandpass second-order filter can be obtained using the simulated active inductor of Figure 1 as shown in Figure 2. Derive the transfer function V_2/V_1 of the circuit assuming ideal op-amp. Determine expressions for the filter gain, center frequency and quality factor.

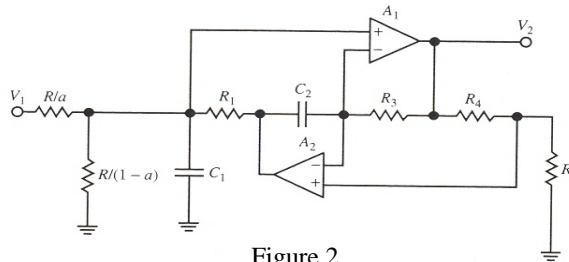

Figure 2

3) A general biquad based on Delyiannis-Friend bandpass filter is shown in Figure 3. The circuit is developed by applying voltage feedforward method. Find the transfer function of the filter V_2/V_1 assuming ideal op-amp. Then give the conditions to realize different standard biquad (i.e. highpass, lowpass, bandpass, notch, allpass, highpass notch and lowpass notch)

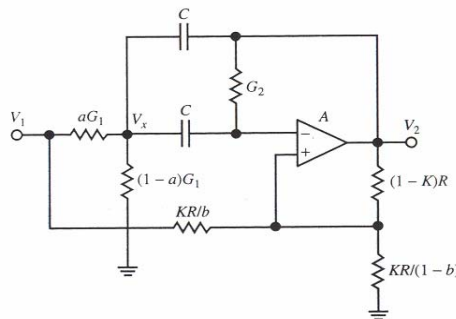

Figure 3

4) Design a circuit using Ackerberg-Mossberg biquad to realize the following transfer function with a normalized frequency parameter $s = j\omega / \omega_o$ where $\omega_o = 2\pi 3.6 \text{krad} / \text{s}$. Maximize the dynamic range.

$$T(s) = \frac{H_M s(s^2 + 1)}{(s^2 + 0.2s + 0.87)(s^2 + 0.5s + 1)}$$