

KING FAHD UNIVERSITY OF PETROLEUM & MINERALS

Electric Engineering Department

EE 306 Electric Energy Engineering - Experiment#5

Load Characteristics of Shunt and Compound DC Generators

Objectives:

1. To study the load voltage vs. current characteristics of shunt connected DC generator.
2. Study the load characteristics of a compound generator.

Apparatus:

- 1 DC motor-generator set
- 1 Tachometer
- 1 DC Voltmeter
- 2 DC Ammeters
- 1 Power Supply
- 1 Resistive load

Theory:

The terminal voltage of a shunt generator is written as:

$$V_t = E_a - I_a R_a \quad (1)$$

Where $I_a = I_f + I_L$

I_f is the shunt current and
 I_L is the load current

For a short shunt compound generator, the terminal equation is modified to

$$V_t = E_a - I_a R_a - I_L R_{sc} \quad (2)$$

Where R_{sc} is the resistance of the series winding.

Procedure:

1. Record the rated currents and voltages of the DC generator and the motor. Record the rated speed of the motor and generator.
2. Make the connection as shown in fig.1.

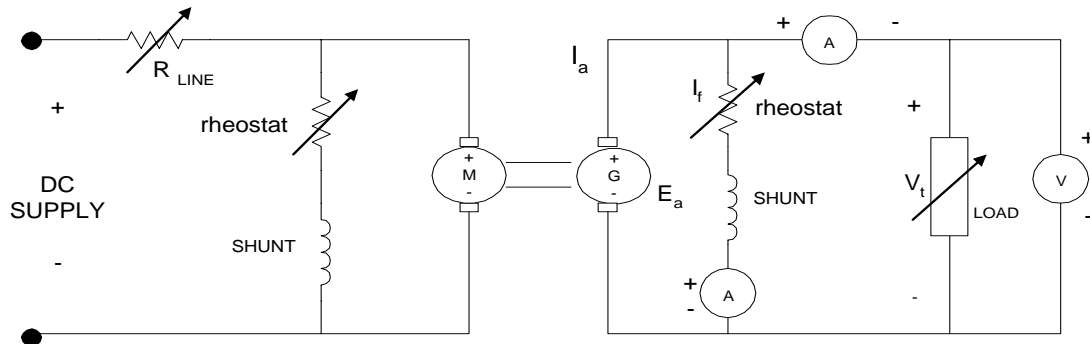
**Fig.1: Connection Diagram For Shunt Generator**

3. Set the generator shunt field rheostat to its maximum value.
4. Set the motor shunt field to its minimum value.
5. Adjust the motor speed to almost rated value. You can go slightly higher than the rated one. The motor speed can be adjusted by changing the resistance in the motor field winding or with series resistance R_{Line} .
6. Adjust the generator voltage to its rated value by controlling the field rheostat. Keep the load disconnected during the voltage buildup.
7. Gradually change the load resistance from no load to about 120 % rated load. Maintain the motor speed to same value.
8. Record the speed of the motor. Enter the load voltage, load current and field current as in table.1 for different loading conditions. Take at least 10 sets of readings.

Table.1

V_L								
I_L								
I_f								

9. Repeat the procedure for the compound generator given in fig.2.

10. Enter your readings in table similar to table.1.

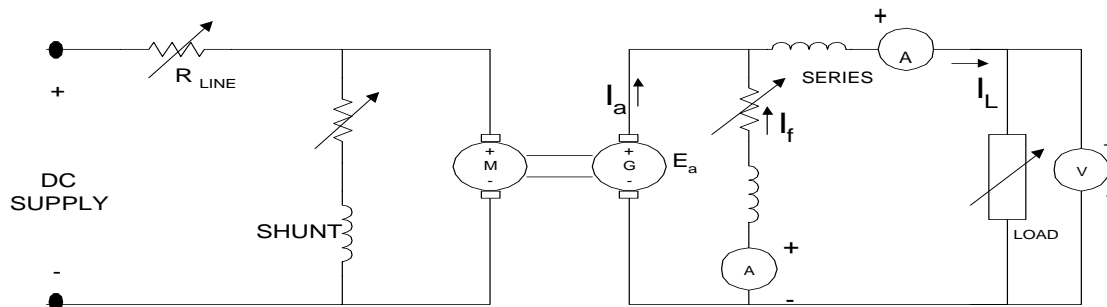

Fig.2: Connection Diagram for Compound Generator

REPORT:

1. Plot the load voltage and field current of the shunt generator against the load current.
2. Repeat the above for the compound machine.
3. Find the voltage regulation at rated load from your experimental results for both shunt and compound machines.
4. Comment which generator is better in terms of load characteristics and why?