

# King Fahd University of Petroleum and Minerals

University Diploma Program  
Electronic Equipment Maintenance  
Lab Instructor: Muhammad Ajmal Khan

## EET-027, Experiment # 8

### Strain Gauge Measurement by Applying Displacement using Strain Indicator

#### Objectives:

Measuring strain when the strip end is displaced in the strain gauge micrometer device.

#### Apparatus:

Strain gauge

Strain gauge micrometer

Different Weights 1 kg, 2k, 5 kg.

Strain Indicator

#### Theory:

The strain gauge is a transducer employing electrical resistance variation to sense the strain produced by a force or weight. It is a very versatile detector for measuring weight, pressure, mechanical force, or displacement.

The Model P-3500 Strain Indicator is a portable, battery-powered instrument with unique features for use in stress analysis testing, and for use with strain gage based transducers. In use, the operator follows a logical sequence of setup steps by activating color-coded push-button controls to prepare the instrument for making accurate and reliable measurements. The P-3500 also incorporates a highly stable DC amplifier, precisely regulated bridge excitation supply, and precisely settable gage factor controls.

Static measurements are displayed directly on the indicator's readout with 1 micro-strain resolution. The instrument will accept full-, half-, or quarter-bridge strain gage inputs, and all required bridge completion components for 120, 350 and 1000 ohm gages are built in.

Gage factor is precisely settable (to a resolution of 0.001) by a front-panel 10-turn potentiometer, and is displayed on the digital readout when the gage factor push button is depressed.

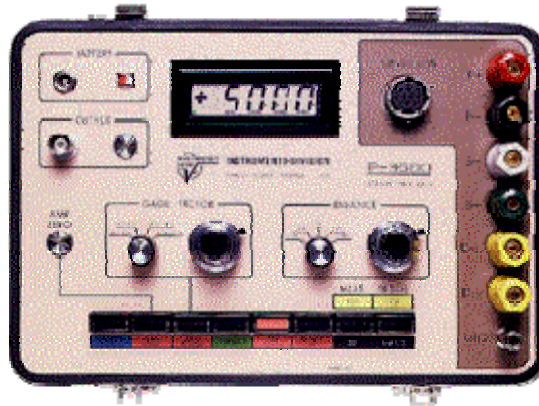

**Strain Indicator P-3500 Front Panel**

## Procedure:

### 1. Measuring Strain using Strain Indicator:

The P-3500 is designed for ease of operation, the push-button switches and front panel controls are arranged such that the proper setup procedure generally follows a straightforward left-to-right sequence. To measure the strain, the steps is outlined below:

1. Select 1/4-1 /2 position of BRIDGE push button.
2. Select XI position of MULT push button.
3. Connect strain gage to binding posts connector. These binding posts are color-coded in accordance with conventional practice, and are clearly labeled. Input connections are shown on the inside cover of the instrument.
4. Depress AMP ZERO push button. Allow instrument to warm up for two minutes minimum. Set AMP ZERO control for a readout display of  $\pm 0000$ . This adjustment must be made with MULT in XI position.
5. Depress GAGE FACTOR push button. Set GAGE FACTOR range switch and GAGE FACTOR control for the desired gage factor.
6. Depress the RUN push button. Set the BALANCE switch and the BALANCE control for a reading of  $\pm 0000$ . This setting must be made with the MULT in the XI position.

7. Depress the CAL push button and verify calibration of the instrument.
8. Select the XI or XI 0 MUL T position as required.
9. Depress the RUN push button. Displace the end of strip and record the reading of strain in the table 1.
10. Plot the graph of Strain versus Resultant Displacement and find the slope of the graph and find strain at displacement of 0.115 inch from graph.

**Table 1**

S. No.	Displacement (inch)	Resultant Displacement (x-a) (inch)	Strain (micro-strain)
1	a =		0
2			
3			
4			
5			
6			
7			
8			
9			
10			
11			
12			
13			

**2. Measuring Differential Voltage of Full Bridge Circuit when Strip is displaced:**

1. Connect strain gauge with the bridge circuit as shown the following figure. Set the power supply to 10 Volts and all three resistances are 120 ohms.

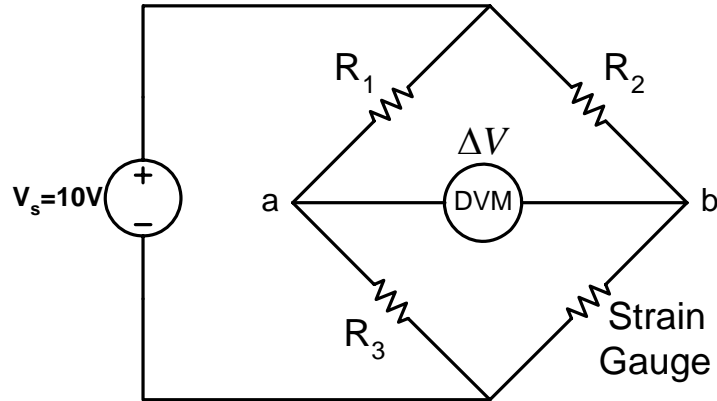

2. Find the voltage difference ( $\Delta V$ ) across nodes “a” and “b” using digital volt-meter (DVM) without any displacement and record the value in the table 2.
3. Apply some displacement using micrometer and find the voltage difference ( $\Delta V$ ) using digital volt-meter (DVM) and record the values in the following table 2.
4. Plot the graph of differential voltage versus Resultant Displacement and find the slope of the graph and find the differential voltage at displacement of 0.115 inch from graph.

**Table 1**

S. No.	Displacement (inch)	Resultant Displacement (x-a) (inch)	Differential Voltage (Volts)
1	a =		0
2			
3			
4			
5			
6			
7			
8			

9			
10			

**Conclusions:**

Compare the slope of the two graphs? And write your comments.