

Experiment # 1

ELECTRIC FIELD AND POTENTIAL INSIDE THE PARALLEL PLATE CAPACITOR

OBJECTIVE

To verify the relationship between the voltage, the electric field and the spacing of a parallel plate capacitor.

EQUIPMENT

1. Capacitor plate (two).
2. Electric field meter (1 $KV/m = 1mA$).
3. Power supply DC 12V and 250V (variable).
4. Multi-meters (two).
5. Plastic ruler (100 cm).
6. Plastic and wooden sheets.

INTRODUCTION

Assume one of the capacitor plates is placed in the y-z plane while the other is parallel to it at distance d as shown in Figure 1. The effect of the boundary disturbance due to the finite extent of the plates is negligible. In this case, the electric field intensity \vec{E} is uniform and directed in x-direction. Since the field is irrotational ($\vec{E} = -\nabla V = \vec{0}$), it can be represented as the gradient of a scalar field V

$$\vec{E} = -\nabla V = -\frac{\partial V}{\partial x} \dots\dots\dots (1)$$

which can be expressed as the quotient of differences

$$\vec{E} = -\frac{V_1 - V_o}{x_1 - x_o} = -\frac{V_A}{d} \dots\dots\dots (2)$$

where V_A is the applied voltage and d is the distance between the plates. The potential of a point at position x in the space between the plates is obtained by integrating the following equation

$$\frac{\partial V}{\partial x} = \frac{V_A}{d} \dots\dots\dots (3)$$

to give

$$V(x) = \frac{V_A}{d} x \dots\dots\dots (4)$$

EXPERIMENTAL SETUP AND PROCEDURE

1. The experimental setup is as shown in Figure 2. Adjust the plate spacing to $d=10$ cm. The electric field meter should be zero-balanced with a voltage of zero.
2. Measure the electric field strength at various voltages ranging from 0 to 250 Volts for $d=10$ cm and summarize the results in a table. Choose a suitable voltage step to produce a smooth curve.
3. Plot a graph of the data of step (2). On the same graph paper, plot the theoretical graph based on equation (2) and compare the theoretical and experimental graphs.
4. Adjust the potential V_A to 200V. Measure the electric field strength as the plate separation is varied from $d=2$ cm to $d=12$ cm. Summarize your results in a table.
5. Plot a graph of the data of step (4). On the same graph paper, plot the theoretical graph based on equation (2) and compare the theoretical and experimental graphs.
6. With a different medium (sheet) inserted between the plates, measure the electric field strength at various voltages ranging from 0 to 30V. The separation between the plates is fixed at $d=1$ cm. Repeat for all sheets.

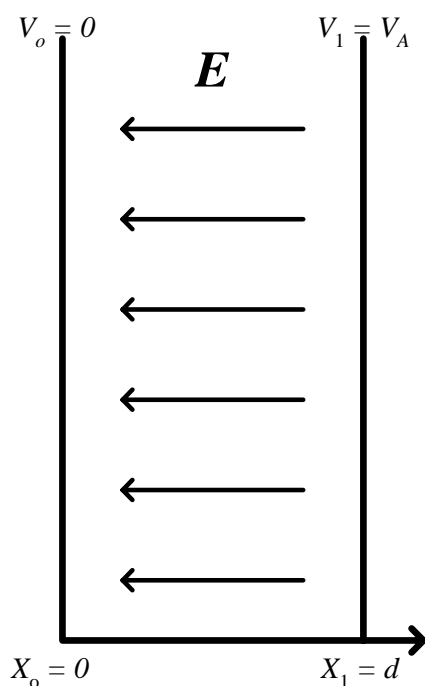

Figure 1: A parallel plate capacitor placed in the yz -plane

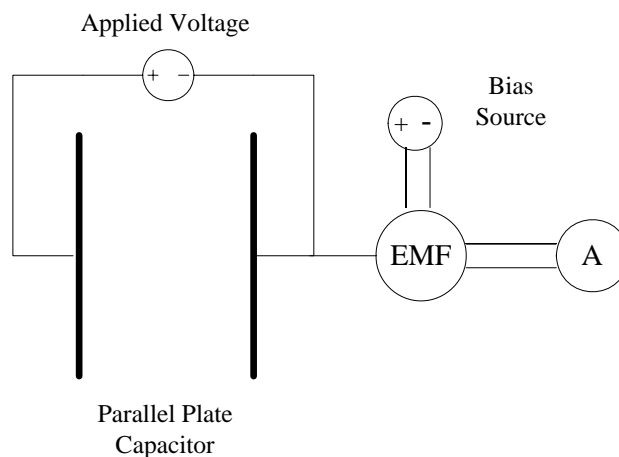

Figure 2: Experimental set-up

Calibration → _____

Table 1: Electric field variation with Voltage (d = 10cm)

Voltage (Volts)	Current, 'I', (mA)	Experimental Electric Field Strength 'E' (V/m)	Theoretical 'E' from Eq(2) $E=V/d$
0			
25			
50			
75			
100			
125			
150			
175			
200			
225			
250			

Table 2: Electric field variation with Plate Separation "d" (V = 200 Volts)

Plate Separation, 'd' (cm)	Current, 'I', (mA)	Experimental Electric Field Strength 'E' (V/m)	Theoretical 'E' from Eq(2) $E=V/d$
2			
4			
6			
8			
10			
12			

Table 3: Electric field variation with Voltage when Plastic Sheet is used ($d = 1 \text{ cm}$)

Voltage (Volts)	Current, 'I', (mA)	Experimental Electric Field Strength 'E' (V/m)
0		
5		
10		
15		
20		
25		
30		

Table 4: Electric field variation with Voltage when Wooden Sheet is used ($d=1\text{cm}$)

Voltage (Volts)	Current, 'I', (mA)	Experimental Electric Field Strength 'E' (V/m)
0		
5		
10		
15		
20		
25		
30		

QUESTIONS FOR DISCUSSION

1. What are the assumptions and simplifications in this experiment? Discuss their effects on the experimental results.
2. Plot theoretical relation between the potential and distance (equation 4) inside a parallel plate capacitor with $d=10 \text{ cm}$ and $V_A=100 \text{ V}$.