

# King Fahd University of Petroleum & Minerals

## Electrical Engineering Department

### EE 400, Experiment # 10

## KFUPM Voice Network: Introduction to Voice Switches and Inter-System Links

### Objectives:

The objective of this demonstration is to introduce students with the equipment and components of a voice network and explain the connectivity of intersystem links.

They will also be introduced to the network management platform for managing the whole KFUPM voice network

### Introduction:

KFUPM voice network comprises of 11 voice communication systems (Nodes) (from Alcatel Corporation, France) networked together to form a homogenous network providing both analog and digital telephony services to the campus.

There are four locally installed systems/nodes and 12 remote installations (7 systems/nodes and 5 remote shelves) scattered through out the university campus mainly to provide the digital service to the remote areas that are otherwise not accessible from the locally installed systems. Each of the locally installed systems (nodes) comprise of four cabinets that in turn consist of one or two shelves (ACTs). Each of the shelf can accommodate a maximum of 28 interface cards.

These interface cards are used for multiple of purposes. For example,

- CPU (The brain of system. Used to control and monitor all the activates of the system/nodes and is duplicated for redundancy)
- PRA (ISDN PRI interface. Provides a link of 30 digital channels. Used to connect two or more systems/nodes)
- INTOF (Digital interface providing 30 channels connectivity at 2 Mbps. Used to connect two or more shelves)
- Z24 (Analog extensions interface. Supporting 24 extensions)
- UA32 (Digital extensions interface. Supporting 32 extensions)
- PCM (Digital interface providing E1 connectivity. Used as a medium for digital external incoming/outgoing trunks)
- NDDI (Analog interface providing 8 interfaces. Used as a medium for analog external incoming/outgoing trunks)
- VG (Used for playing voice guides, do some other signal processing tasks etc)

### External networks and interfaces

**Type of private voice networks:**

1. Homogenous (ABC-F2 or E1 protocol)
2. Alcatel Hetrogeneous (ABC\_F1 protcol)
3. Hetrogeneous (QSIG protocol)

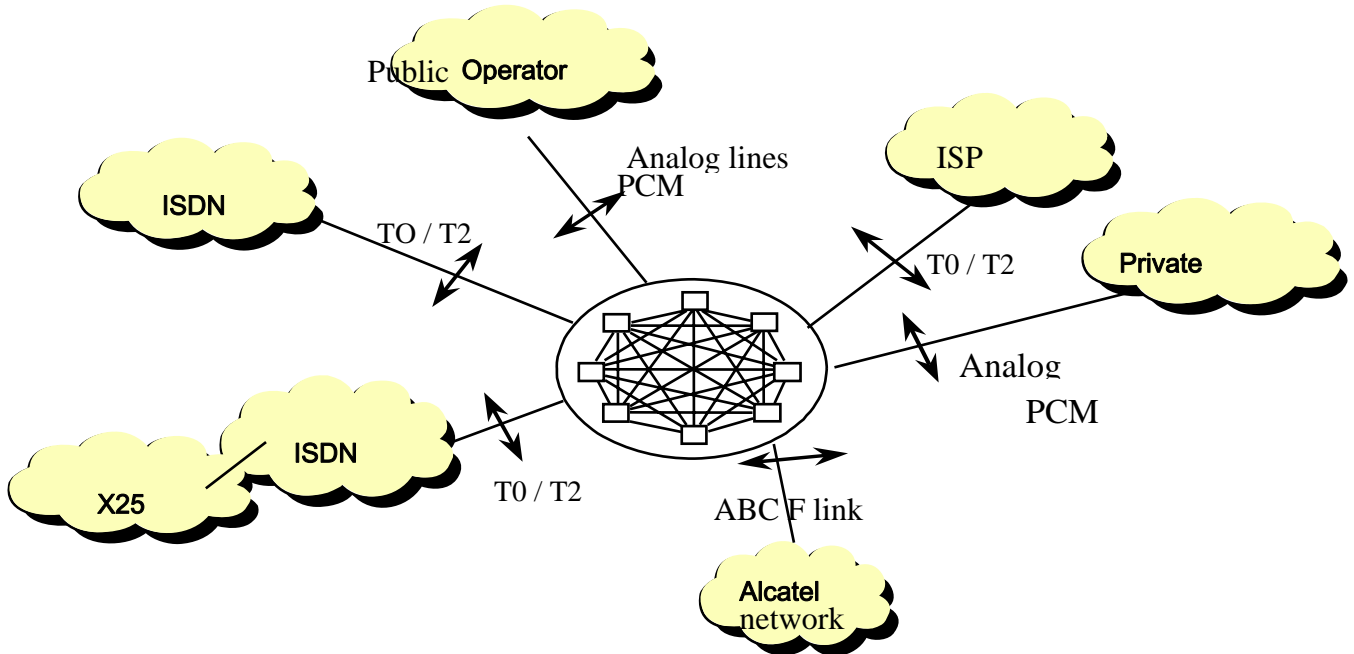

The IP facilities use the following transmission media: - Ethernet network - X25 network - V24 serial links - Inter ACT link.

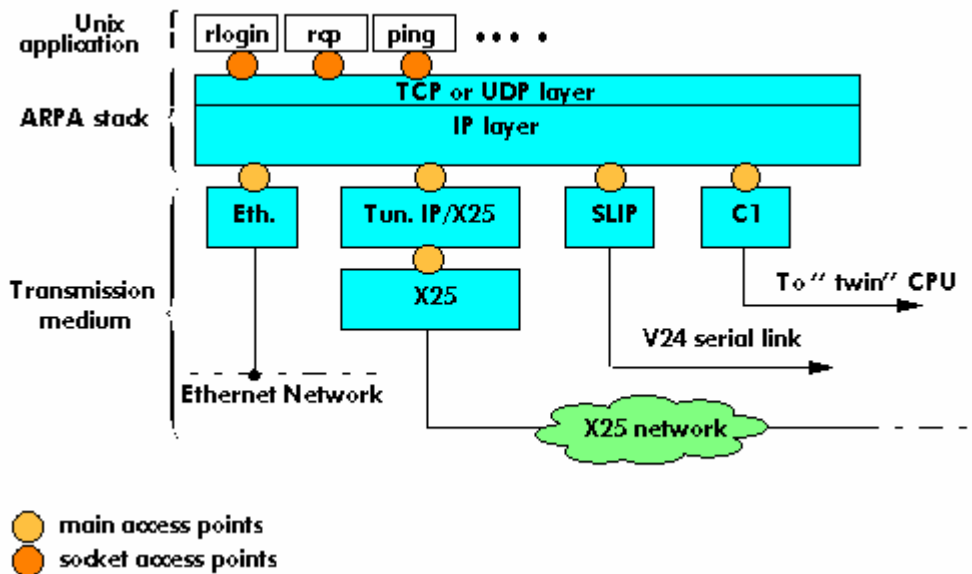

### 1. ETHERNET INTERFACE

The Ethernet interface enables the PABX to be connected to an Ethernet network.

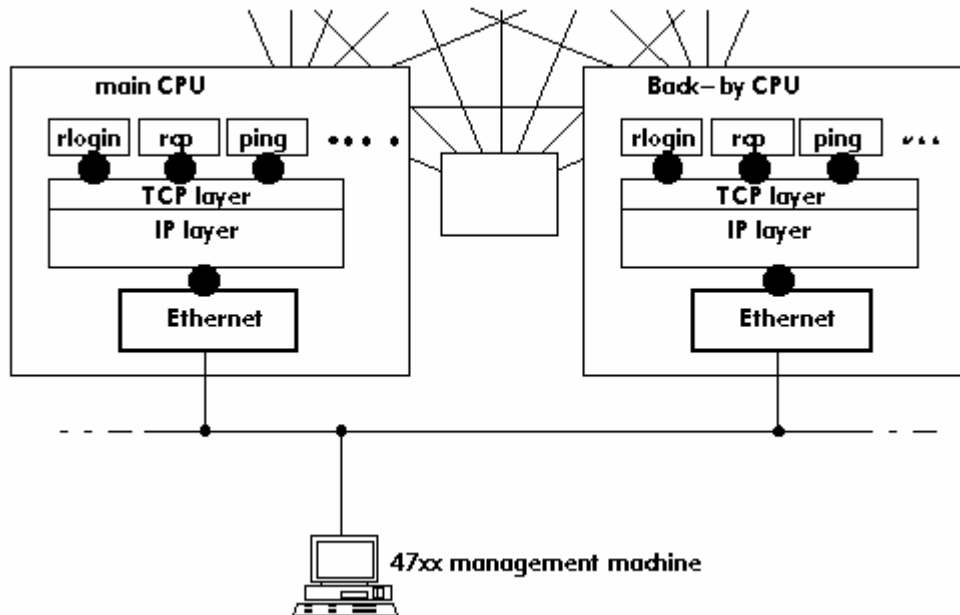

### 2. IP/X25 TUNNEL INTERFACE

The tunnel enables the internal X25 network between the PABXs to act as a communications medium. The function of the IP/X25 tunnel is to transform the datagrams which leave the IP layer into X25 packets. The IP/X25 tunnel also controls the transforming of the off-line IP protocol into on-line X25 protocol. For this, it establishes and releases the X25 connections.

The IP/X25 tunnel only works on ABC links.

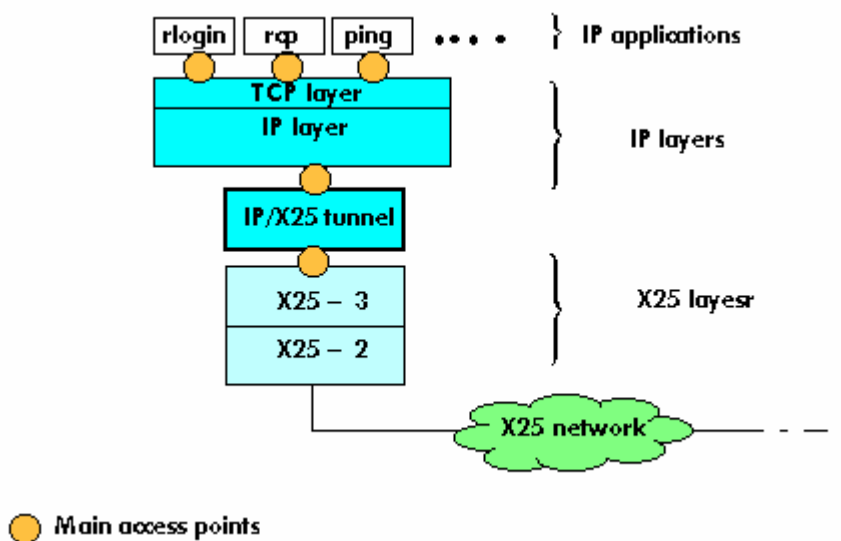

### 3. SERIAL LINK

The management equipment or other equipment of the PABX may be connected by a V24 type serial link. For this mode of communication, two protocols are suggested: the SLIP protocol and the PPP protocol

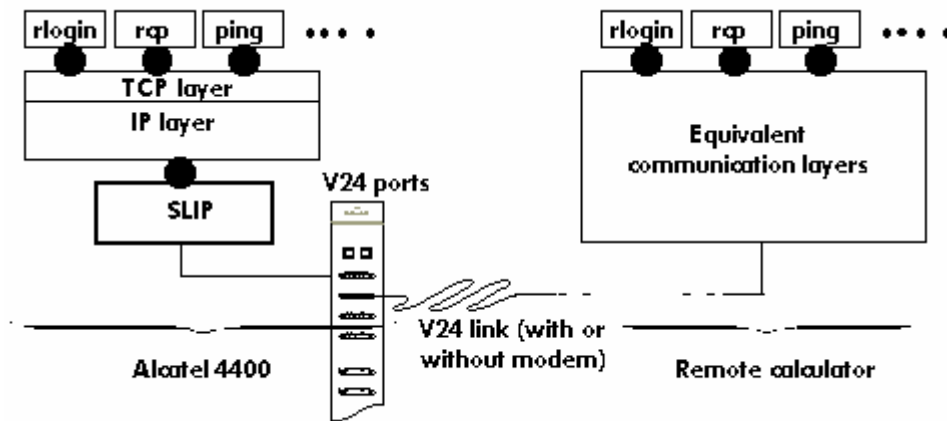

### 4. C1 Link

The C1 link allows the master and slave CPU to communicate with each other via the ACT.

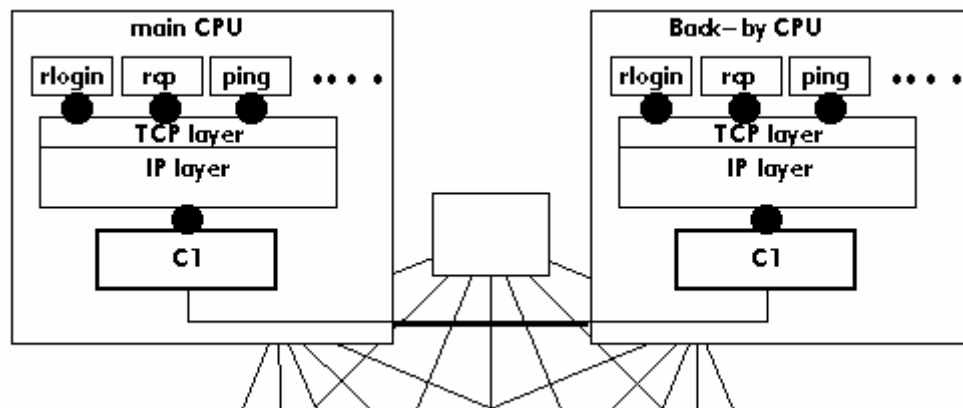

**UA link** The terminal adapters (TA) and dedicated sets are connected to the system via this UA link, which carries 4 x 64Kbit/s channels (3 B channels and one signaling channel). It is used to multiplex voice and data on the same physical link. The UA link presents a 125 micro second frame with the following format:

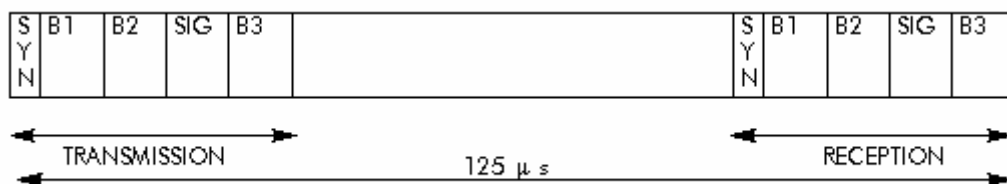

For example, in the case of a V24 terminal connected behind a UA set, the multiplexing is carried out as follows: - the SIG channel carries the UA signaling exchanged between the set and system, - one B channel carries voice, - one B channel carries the V24 terminal data.

### **ISDN interfaces ACT boards**

The ISDN boards that can be connected on the ACT backplane are of the following types: - --

**BRA** board offering 8 E0 bus interfaces

**PRA** board offering 1 E1 interface.

**BPRA** board offering 1 E1 interface and 3 E0 bus interfaces

### **Configuration of Inter-system links (E1/T2):**

- PCM link is E1 link (uses PCM boards)
- ABC link is special link for inter-node connection (uses PRA boards)
- T2 is ISDN link used for public network connection (uses PRA board)

Time slot 0 is used for alarms, Time slot 16 is used for signaling.

### **ABC Link management (Inter node links):**

- PRA coupler management
- Link configuration
- Channel assignments
- IP/X25 Tunnel management

### **ABC Trunk Group management (Links b/w heterogeneous systems):**

- Trunk group creation
- Coupler management

### **QSIG Protocol:**

QSIG is a modern, powerful and intelligent inter-PINX (Private Integrated services Network Exchange) signaling system designed specifically to meet the requirements for sophisticated communications services. It provides:

- a platform for future development supported by international standards organizations;
- a harmonized method for interconnecting multi-vendor equipment;
- a mechanism for manufacturers to provide innovative features within a heterogeneous environment;
- a flexible and cost efficient method of linking PINX equipment;

