

COE 444 - Internetwork Design and Management
Fall 2005 (Term 051)

Homework 2

Date: Tuesday, September 20, 2005

Q1. Given a LAN consisting of six Ethernet segments interconnected by 6 bridges as illustrated in the figure below. Note that the ID of each bridge is its name.

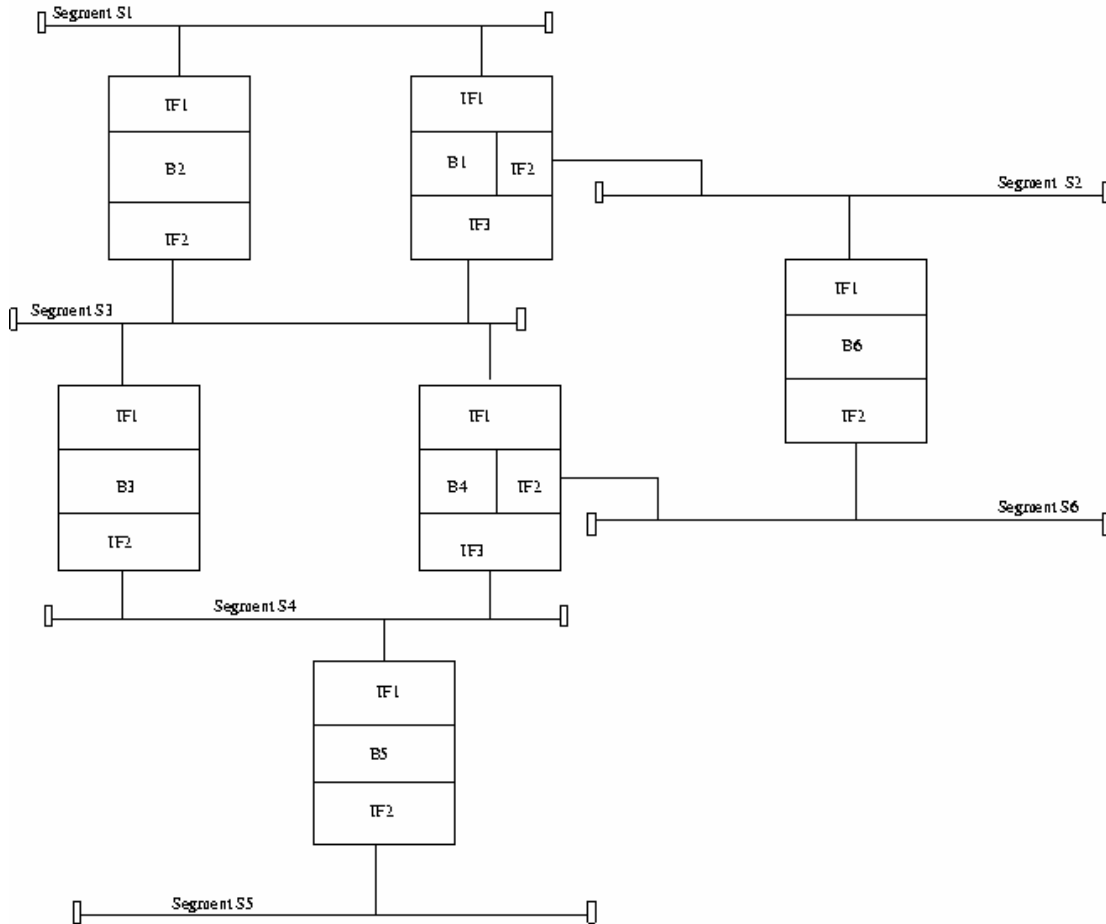

Suppose we are using fixed routing to configure the bridges. Determine the central routing directory for all segments, and the routing tables for Bridges B1 and B3. If alternate routes are available then chose the one with the least number of hops. If they are the same than choose the one with the lowest bridge ID.

Q2. Given a LAN consisting of three 100 Mbps Ethernet segments interconnected by 4 bridges as illustrated in the figure below. Note that the ID of each bridge is its name.

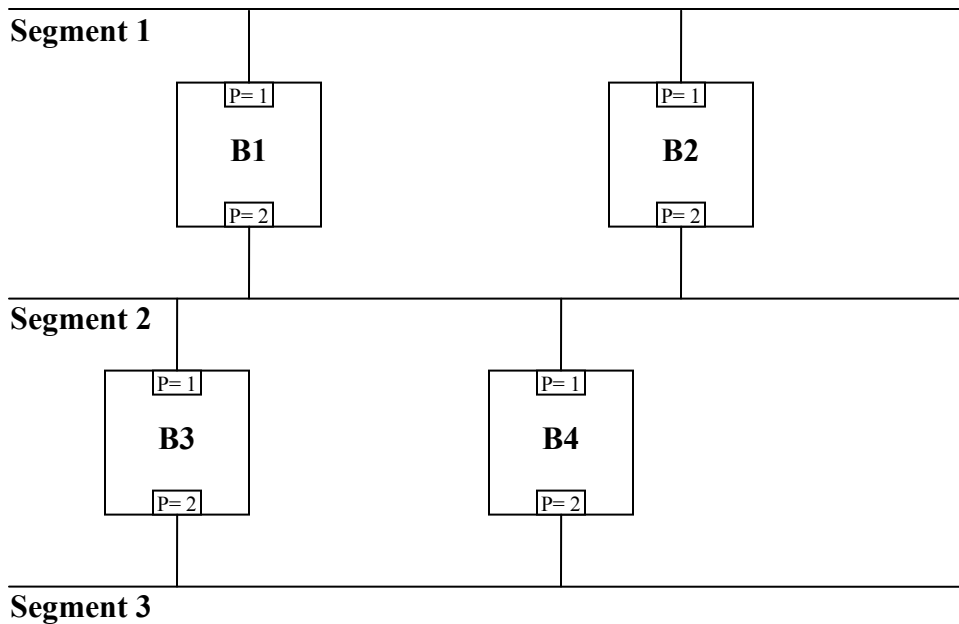

Assume that we are using fixed routing to configure the bridges. Determine the **central routing directory** for all segments, and the **routing table for Bridge B1**. If alternate routes are available then chose the one with the least number of hops. If they are the same then choose the one with the lowest bridge ID.

Q3. Given a LAN consisting of five 10 Mbps Ethernet segments interconnected by two transparent bridges as illustrated in the figure below.

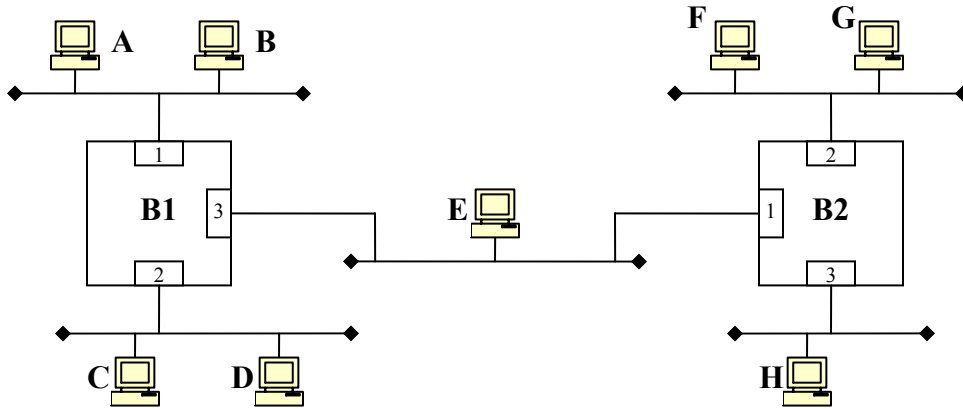

B1 forwarding table has the following entries (the aging time is set initially to 300 seconds):

MAC Address	Port	Aging time
B	1	200
H	3	150

A frame is received without error by Bridge B1 with destination address (DA) and source address (SA) as stated in the following table. Fill the following table with the appropriate information

Frame transmitted	Does B1 forward this frame? If yes, then on which port(s) does B1 forward this frame?	Does B1 add/update an entry to its table? If yes, then update the above table with appropriate changes?
DA = "A", SA = "B"		
DA = "B", SA = "A"		
DA = "H", SA = "C"		
DA = "H", SA = "E"		
DA = "D", SA = "G"		