

# King Fahd University of Petroleum & Minerals Computer Engineering Dept

---

COE 241 – Data and Computer  
Communications

Term 121

Dr. Ashraf S. Hasan Mahmoud

Rm 22-420

Ext. 1724

Email: [ashraf@kfupm.edu.sa](mailto:ashraf@kfupm.edu.sa)

12/24/2012

Dr. Ashraf S. Hasan Mahmoud

1

## Lecture Contents

---

1. Frequency-Division Multiplexing
2. Synchronous Time-Division Multiplexing
3. Statistical Time-Division Multiplexing
4. DSL/ADSL Technology

12/24/2012

Dr. Ashraf S. Hasan Mahmoud

2

## What is MULTIPLEXING?

- A generic term used where more than one application or connection share the capacity of one link
- Why?
  - To achieve better utilization of resources

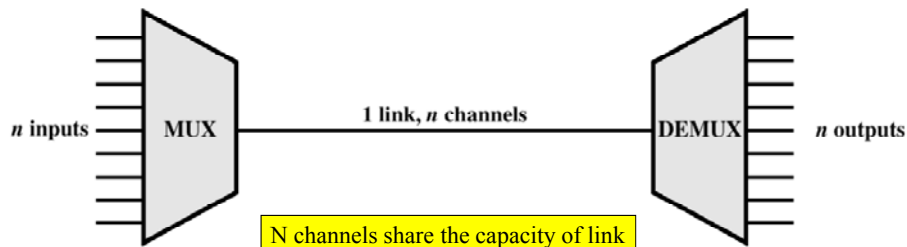

12/24/2012

Dr. Ashraf S. Hasan Mahmoud

3

## Frequency-Division Multiplexing - Transmitter

- $m_i(t)$ : analog or digital information
- Modulated with subcarrier  $f_i \rightarrow s_i(t)$
- $m_b(t)$  composite baseband modulating signal
- $m_b(t)$  modulated by  $f_c \rightarrow$  The overall FDM signal  $s(t)$

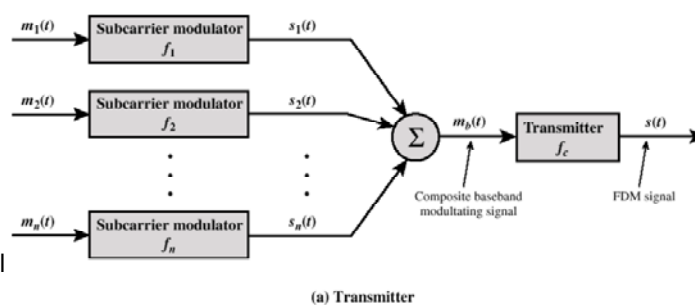

(a) Transmitter

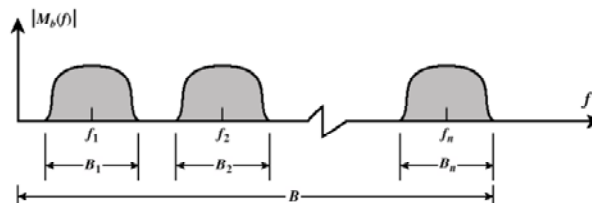

12/24/2012

Dr. Ashraf S. Hasan Mahmoud

Spectrum function of composite baseband modulating signal  $m_b(t)$

## Frequency-Division Multiplexing - Receiver

- $m_b(t)$  is retrieved by demodulating the FDM signal  $s(t)$  using carrier  $f_c$
- $m_b(t)$  is passed through a parallel bank of bandpass filters – centered around  $f_i$
- The output of the  $i^{\text{th}}$  filter is the  $i^{\text{th}}$  signal  $s_i(t)$
- $m_i(t)$  is retrieved by demodulating  $s_i(t)$  using subcarrier  $f_i$

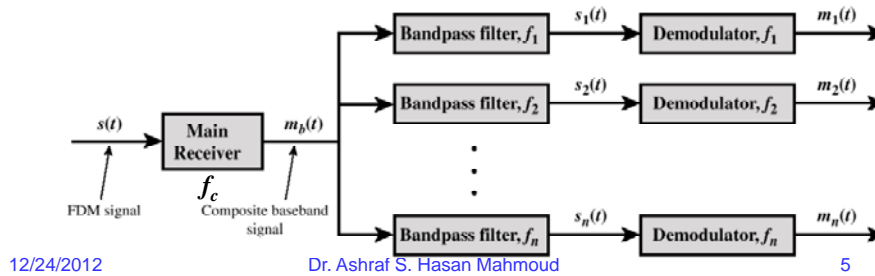

## Frequency-Division Multiplexing - Example 1: Cable TV

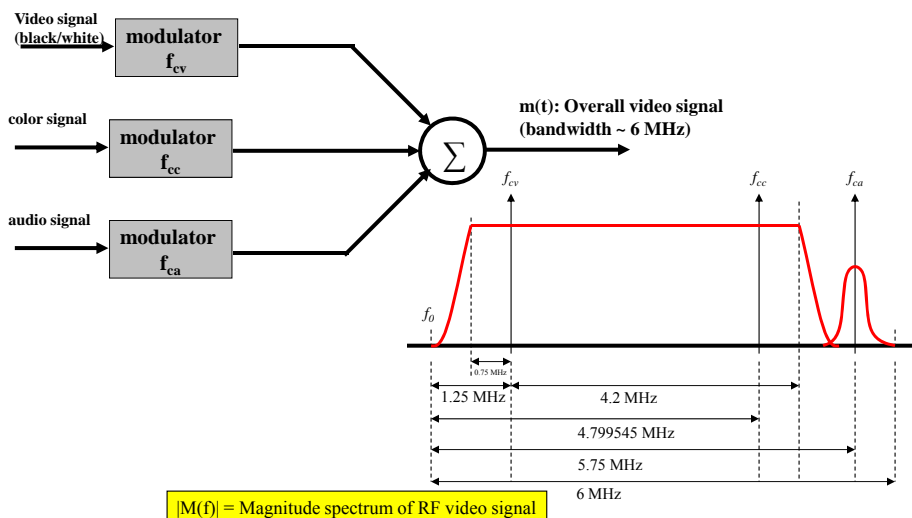

# Frequency-Division Multiplexing - Example 1: Cable TV - cont'd

- Cable has BW ~ 500 MHz → 10s of TV channels can be carried *simultaneously* using FDM
- Table 8.1: Cable Television Channel Frequency Allocation (partial): 61 channels occupying bandwidth up to 450 MHz

Channel No	Band (MHz)	Channel No	Band (MHz)	Channel No	Band (MHz)
2	54-60	22	168-174	42	330-336
3	60-66	23	216-222	43	336-342
4	66-72	24	222-234	44	342-348
5	76-82	...	...	...	...
6	82-88				
7	174-180				
8	180-186				
9	186-192				
10	192-198				
11	198-204				
12	204-210				
13	210-216				
FM	88-108				
14	120-126				
15	126-132				
16	...				
...	...				

12/24/2012

Dr. Ashraf S. Hasan Mahmoud

7

## Frequency-Division Multiplexing - Example 2: Voiceband Signals

- $m_1(t)$ : voiceband signal – bandwidth = 4000 Hz
- When modulated by a carrier  $f_1 = 64$  KHz → two identical sidebands; overall bandwidth =  $2 \times 4$  KHz = 8 KHz
- Information of  $m_1(t)$  is preserved if one of the sidebands is eliminated (filtered out) → bandwidth of modulated signal = 4 KHz
- (c) shows spectrum for composite signal using three subcarriers



(a) Spectrum of  $m_1(t)$ , positive  $f$

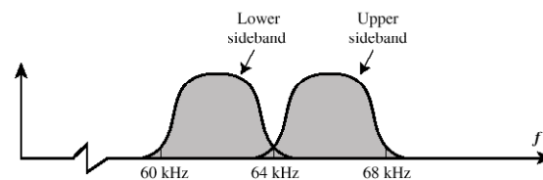

(b) Spectrum of  $s_1(t)$  for  $f_1 = 64$  kHz

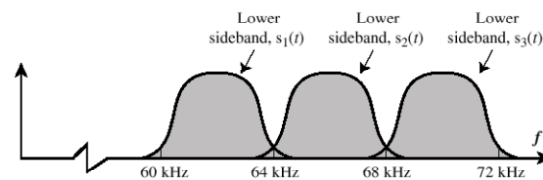

(c) Spectrum of composite signal using subcarriers at 64 kHz, 68 kHz, and 72 kHz

12/24/2012

Dr. Ashraf S. Hasan Mahmoud

8

## Frequency-Division Multiplexing - Example 2: Voiceband Signals (2)

- Animation of FDM concept for voice calls

12/24/2012

Dr. Ashraf S. Hasan Mahmoud

9

## Frequency-Division Multiplexing - Analog Carrier Systems

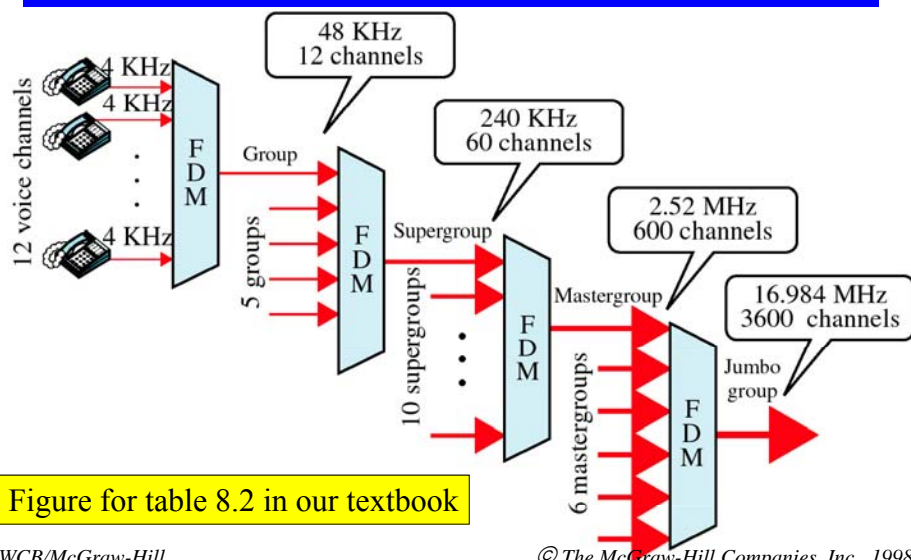

## Synchronous Time-Division Multiplexing - Transmitter

- Digital sources  $m_i(t)$  – usually buffered
- A scanner samples sources in a cyclic manner to form a frame
- $m_c(t)$  is the TDM stream or frame  $\rightarrow$  frame structure is fixed
- Frame  $m_c(t)$  is then transmitted using a modem  $\rightarrow$  resulting analog signal is  $s(t)$

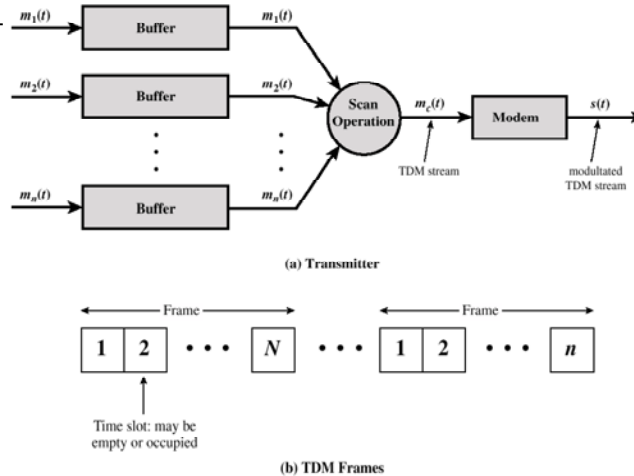

12/24/2012

Dr. Ashraf S. Hasan Mahmoud

11

## Synchronous Time-Division Multiplexing - Receiver

- TDM signal  $s(t)$  is demodulated  $\rightarrow$  result is TDM digital frame  $m_c(t)$
- $m_c(t)$  is then scanned into  $n$  parallel buffers;
- The  $i^{\text{th}}$  buffer correspond to the original  $m_i(t)$  digital information

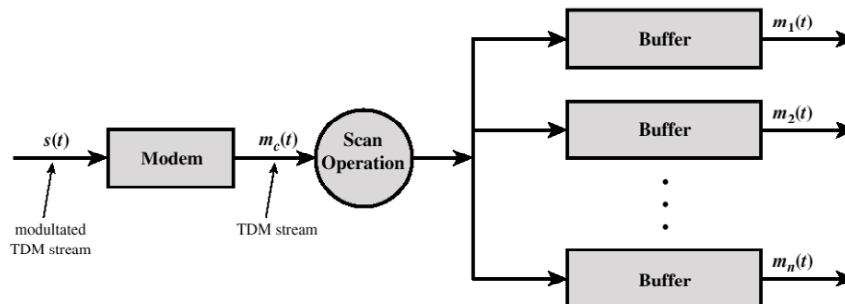

12/24/2012

Dr. Ashraf S. Hasan Mahmoud

12

## Synchronous Time-Division Multiplexing

---

- Animation of Synchronous TDM concept

## Synchronous Time-Division Multiplexing – Bit/Character Interleaving

---

- TDM frame: sequence of slots – fixed structure – NOTE: no header/error control for this frame
  - One or more slots per digital source
  - The order of the slots dictated by the scanner control
  - The slot length equals the transmitter buffer length:
    - Bit: bit interleaving
      - Used for synchronous sources – but can be used for asynchronous sources
    - Character: character-interleaving
      - Used for asynchronous sources
      - Start/stop bits removed at tx-er and re-inserted at rx-er
- Synchronous TDM: time slots are pre-assigned to sources and FIXED
  - If there is data, the slot is occupied
  - If there is no data, the slot is left unoccupied

This is a cause of inefficiency!

# TDM Link Control

- TDM frame:
  - No header and no error detection/control – these are per connection procedures
  - Frame synchronization is required – to identify beginning and end of frame
    - Added-digit framing: One control bit is added to each start of frame – all these bits from consecutive frame form an identifiable pattern (e.g. 1010101...)
    - These added bits for framing are inserted by system → control channel
    - Frame search mode: Rx-er parses incoming stream until it recognizes the pattern → then TDM frame is known
- Pulse stuffing:
  - Different sources may have separate/different clocks
  - Source rates may not be related by a simple rational number
  - Solution: inflate lower source rates by inserting extra dummy bits or pulses to match the locally generated clock speed

12/24/2012

Dr. Ashraf S. Hasan Mahmoud

15

# TDM – Example 1

- Step1: convert analog sources to digital using PCM
  - The *sampling theorem* determines the no of samples/sec
- The analog sources produce 16 sample/sec altogether → 64 kb/s when converted to digital
- Note pulse stuffing is used to raise the 7.2 kb/s rate to 8 kb/s (a rational fraction of 64 kb/s) for digital sources

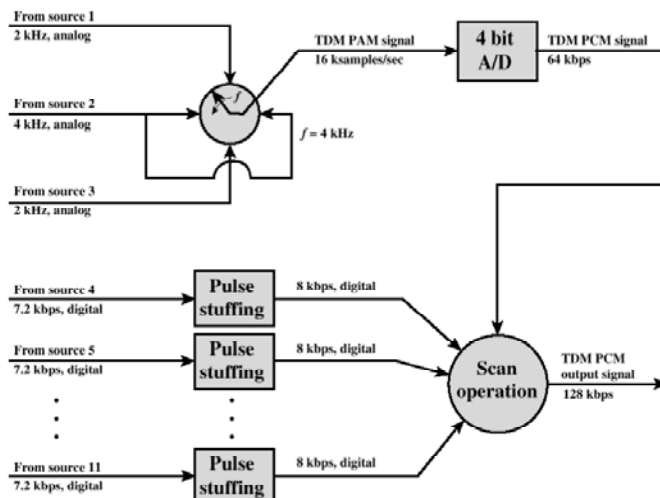

12/24/2012

Dr. Ashraf S. Hasan Mahmoud

16



# TDM – Example2: Digital Carrier Systems

- Voice call is PCM coded → 8 b/sample
- DS-0: PCM digitized voice call – R = 64 Kb/s
- Group 24 digitized voice calls into one frame as shown in figure → DS-1: 24 DS-0s
- Note channel 1 has a digitized sample from 1<sup>st</sup> call; channel 2 has a digitized sample from 2<sup>nd</sup> calls; etc.

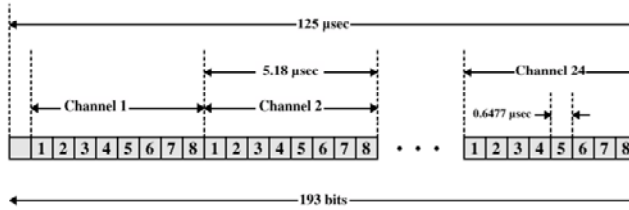

Notes:

1. The first bit is a framing bit, used for synchronization.
2. Voice channels:
  - 8-bit PCM used on five of six frames.
  - 7-bit PCM used on every sixth frame; bit 8 of each channel is a signaling bit.
3. Data channels:
  - Channel 24 is used for signaling only in some schemes.
  - Bits 1-7 used for 56 kbps service
  - Bits 2-7 used for 9.6, 4.8, and 2.4 kbps service.

Figure 8.9 DS-1 Transmission Format

12/24/2012

Dr. Ashraf S. Hasan Mahmoud

17

Figure 8-28

## T-1 Frame

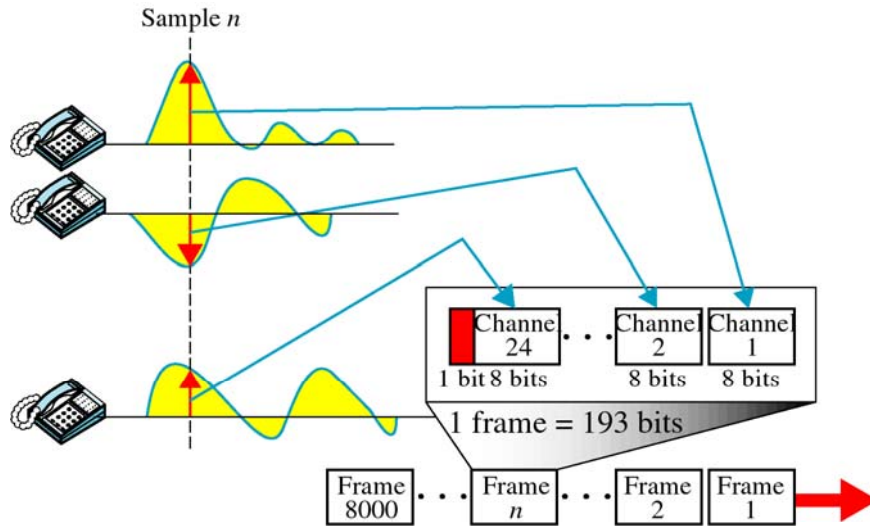

12/24/2012

Dr. Ashraf S. Hasan Mahmoud

The McGraw-Hill Companies, Inc. 181998

## TDM – Example2: Digital Carrier Systems (2)

- TDM

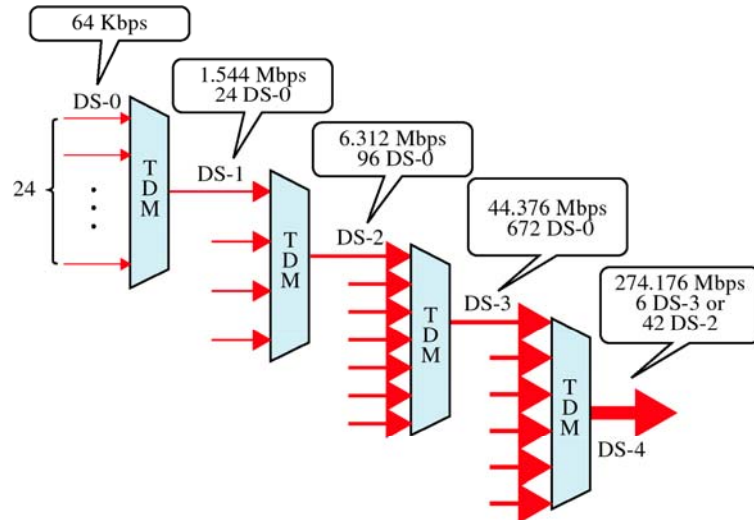

12/24/2012

Dr. Ashraf S. Hasan Mahmoud

19

## Example: Problem 8-8

- 8-8: In the DS-1 format, what is the control signal data rate for each voice channel?

**Solution:**

There is one control bit per channel per six frames.  
Each frame lasts 125  $\mu$ sec. Thus:

$$\text{Data Rate} = 1/(6 \times 125 \times 10^{-6}) = 1.33 \text{ kbps}$$

12/24/2012

Dr. Ashraf S. Hasan Mahmoud

20

# Statistical Time-Division Multiplexing

- **Dynamic and on-demand allocation of time slots**

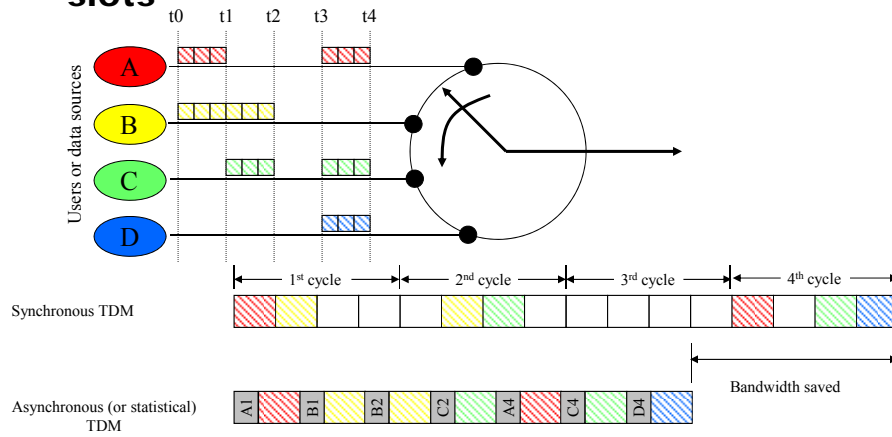

12/24/2012

Dr. Ashraf S. Hasan Mahmoud

21

# Statistical Time-Division Multiplexing Frame Format

- **Clearly, the aim of statistical TDM is increase efficiency by not sending empty slots**
- **But it requires overhead info to work:**
  - **Address field**
  - **Length field**



(a) Overall frame



(b) Subframe with one source per frame

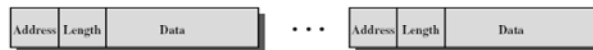

(c) Subframe with multiple sources per frame

12/24/2012

Dr. Ashraf S. Hasan Mahmoud

22

## Statistical Time-Division Multiplexing

---

- Animation of Asynchronous TDM concept

## Asymmetric Digital Subscriber Line (ADSL)

---

- **References:**
  - Chapter 8 – section 4
  - [http://whatis.techtarget.com/definition/0,289893,sid9\\_gci213915,00.html#dslsumry](http://whatis.techtarget.com/definition/0,289893,sid9_gci213915,00.html#dslsumry)
  - DSL forum at:  
[http://www.dslforum.org/about\\_dsl.htm?page=aboutdsl/tech\\_info.html](http://www.dslforum.org/about_dsl.htm?page=aboutdsl/tech_info.html)

## Digital Subscriber Line (DSL) Technology

- Provides access to wide area public digital network – or the internet
- Uses the existing telephone wire at home
  - The wire originally deployed to carry voice (up to 4 kHz) signal
  - The wire has a bandwidth ~ MHz or more depending on distance
- DSL modem – a modem that provides high-speed digital transmission over ordinary telephone wire
- xDSL: refers to the different flavors of the DSL technology: ADSL, HDSL, VDSL, and RADSL

12/24/2012

Dr. Ashraf S. Hasan Mahmoud

25

## Digital Subscriber Line (DSL) Technology - Evolution

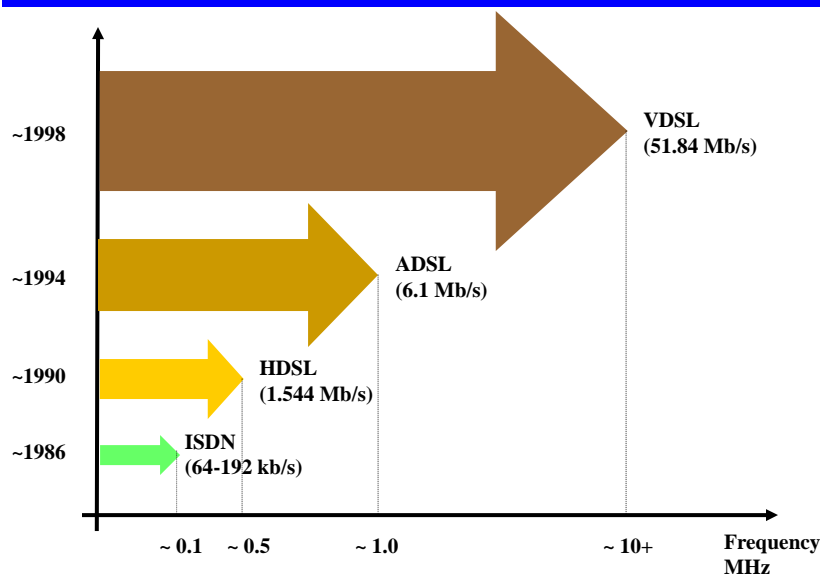

## Digital Subscriber Line (DSL) Technology

---

- **Connects home/small businesses to the central office**
- **Provides up to 8.448 Mb/s on downlink – motion video (on demand) is possible**
- **Typical ADSL bit rates:**
  - Downlink 512 kb/s ~ 1.544 Mb/s
  - Uplink 128 kb/s

12/24/2012

Dr. Ashraf S. Hasan Mahmoud

27

## Asymmetric Digital Subscriber Line (ADSL) – cont'd

---

- **Asymmetric bit rate provided on downlink (from central office to subscriber) is greater than bit rate provided on uplink (from subscriber to central office)**
  - **Matches our use of the internet – more downloads compared to uploads**
- **ADSL uses FDM or Echo Canceling on the telephone wire**

12/24/2012

Dr. Ashraf S. Hasan Mahmoud

28

# ADSL Equipment

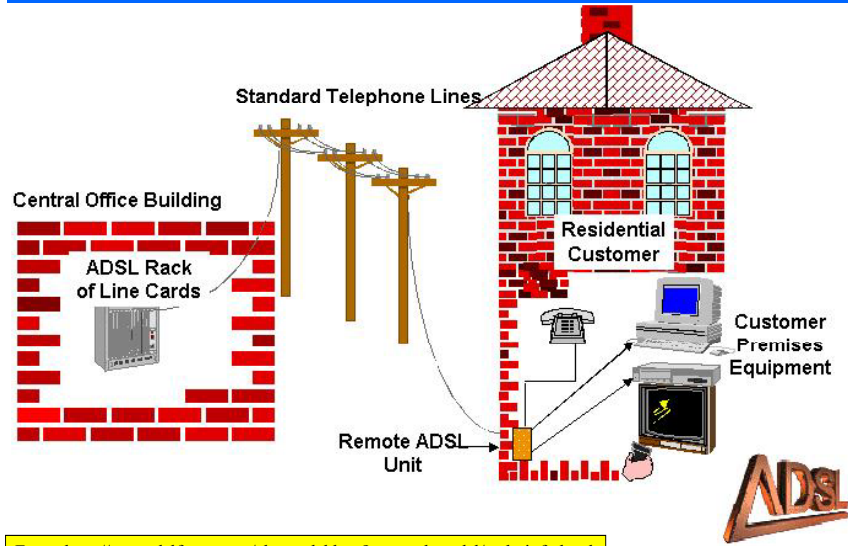

From: [http://www.dslforum.org/about\\_dsl.htm?page=aboutdsl/tech\\_info.html](http://www.dslforum.org/about_dsl.htm?page=aboutdsl/tech_info.html)

# ADSL Modem Structure

DSLAM: Digital Subscriber Line Access Multiplexer

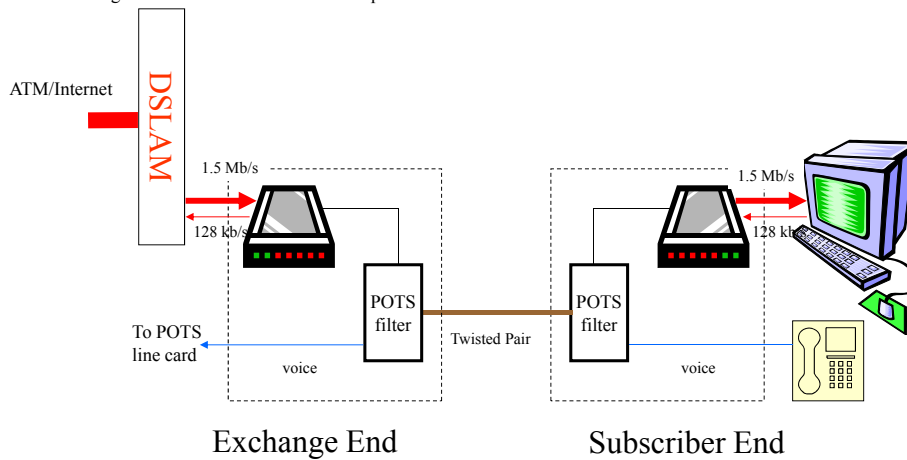

From: [http://www.dslforum.org/about\\_dsl.htm?page=aboutdsl/tech\\_info.html](http://www.dslforum.org/about_dsl.htm?page=aboutdsl/tech_info.html)

30

# ADSL and FDM

- Lower range 0-4 kHz – voice
- Data uses **25 kHz and up**
  - Uplink: 25 to ~200 kHz
  - Downlink: ~250 to 1000 kHz
- FDM is used to multiplex voice, uplink, and downlink signals

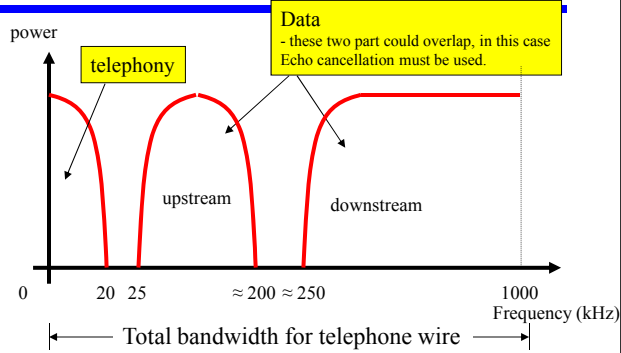

- FDM is used within the uplink band and downlink bands to multiplex multiple bit streams
- Echo cancellation: in this case the uplink and downlink bands overlap – logic at both ends is required to separate the two signals (variable uplink bandwidth – avoiding using the higher bandwidth of the wire)

12/24/2012

Dr. Ashraf S. Hasan Mahmoud

31

# Comparison of xDSL Alternatives

	ADSL	HDSL	SDSL	VDSL
Data rate	1.5 to 9 Mbps downstream 16 to 640 kbps upstream	1,544 or 2,048 Mbps	1,544 or 2,048 Mbps	13 to 52 Mbps downstream 1.5 to 2.3 Mbps upstream
Mode	Asymmetric	Symmetric	Symmetric	Asymmetric
Copper Pairs	1	2	1	1
Range (24-gauge UTP)	3.7 to 5.5 km	3.7 km	3.0 km	1.4 km
Signaling	Analog	Digital	Digital	Analog
Line Code	CAP/DMT	2B1Q	2B1Q	DMT
Frequency	1 to 5 MHz	196 kHz	196 kHz	≥ 10 MHz
Bits/cycle	Varies	4	4	Varies

UTP = unshielded twisted pair

**HDSL:**

- Alternative for T1
- Distance ~ 3.7 km
- Two twisted-pair lines
- Target: Businesses

**SDSL:**

- HDSL version for residential
- Uses single twisted pair
- Uses Echo cancellation

12/24/2012

Dr. Ashraf S. Hasan Mahmoud

32



## Discrete Multitone – 4 kHz Subchannels

- The modulation technique used for ADSL
- The available transmission bandwidth (upstream or downstream) is divided into 4-kHz subchannels
  - Each has its own subcarrier or TONE (therefore the name multitone!)
- A combination of QAM and FDM

12/24/2012

Dr. Ashraf S. Hasan Mahmoud

33

## Bandwidth Division in ADSL

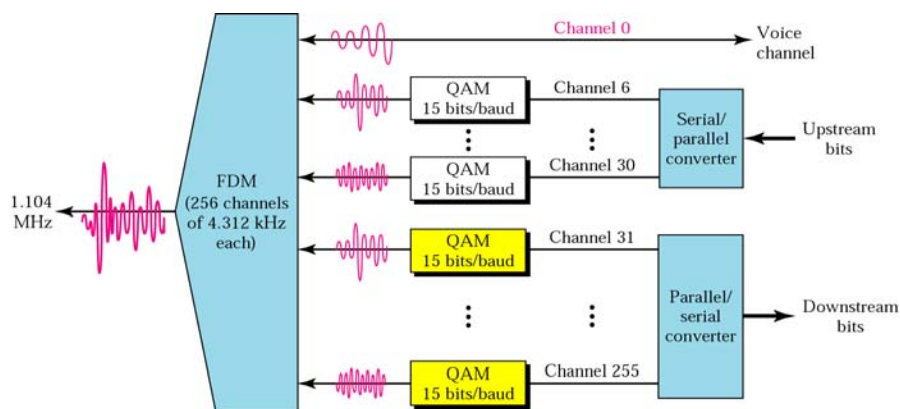

Channel 0 – voice  
Channels: 1-5 - idle  
Channels: 6-30 (25 channels) – upstream data  
Channels: 31-255 (225 channels) – 224 downstream data + 1 control

12/24/2012

Dr. Ashraf S. Hasan Mahmoud

34

# Discrete Multitone - Subchannels

Maximum theoretical download speed (if all wire bandwidth of 1,104kHz = 1104/4.3 = 256 channels is/are utilized) = 60 X 256 = 15.36 Mb/s  
 Practical = 1.5 to 9 Mb/s depending on line distance and quality

- Total usable bandwidth is divided into 4 kHz subchannels
- Each channel can send up to 60 kb/s
- During modem initialization – modem sends test signals on each of these subchannels

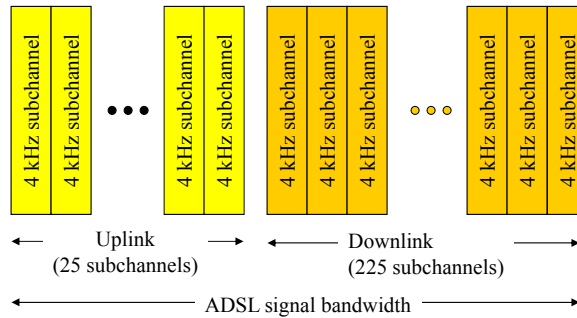

- $i^{\text{th}}$  Subchannel is assigned a rate equal to  $\alpha_i \times 60 \text{ kb/s}$  where  $0 \leq \alpha_i \leq 1$

12/24/2012

Dr. Ashraf S. Hasan Mahmoud

35

# Discrete Multitone Transmitter

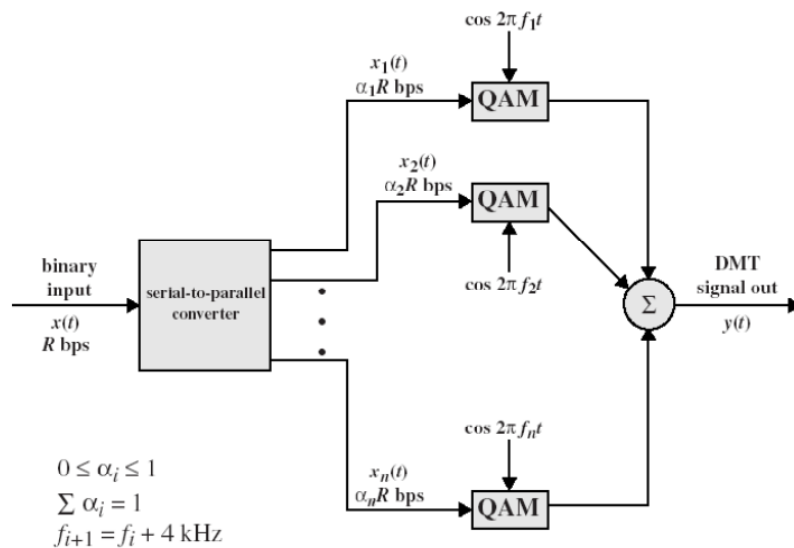

36

## DSLAM (Digital Subscriber Line Access Multiplexer)

---

- DSLAMs sit in a carrier's central office between a subscriber line and the subscriber's service-provider network. They separate voice and DSL traffic and then control and route DSL traffic between the subscriber and the service provider.

12/24/2012

Dr. Ashraf S. Hasan Mahmoud

37

## Problems of INTEREST

---

- Problem List: 8-9, 8-10, 8-11, 8-12, 8-13, and 8-17
- Example on slide 25

12/24/2012

Dr. Ashraf S. Hasan Mahmoud

38