

# Introduction

## Chapter 1

# Uses of Computer Networks

- Business Applications
- Home Applications
- Mobile Users
- Social Issues

# Business Applications (1)

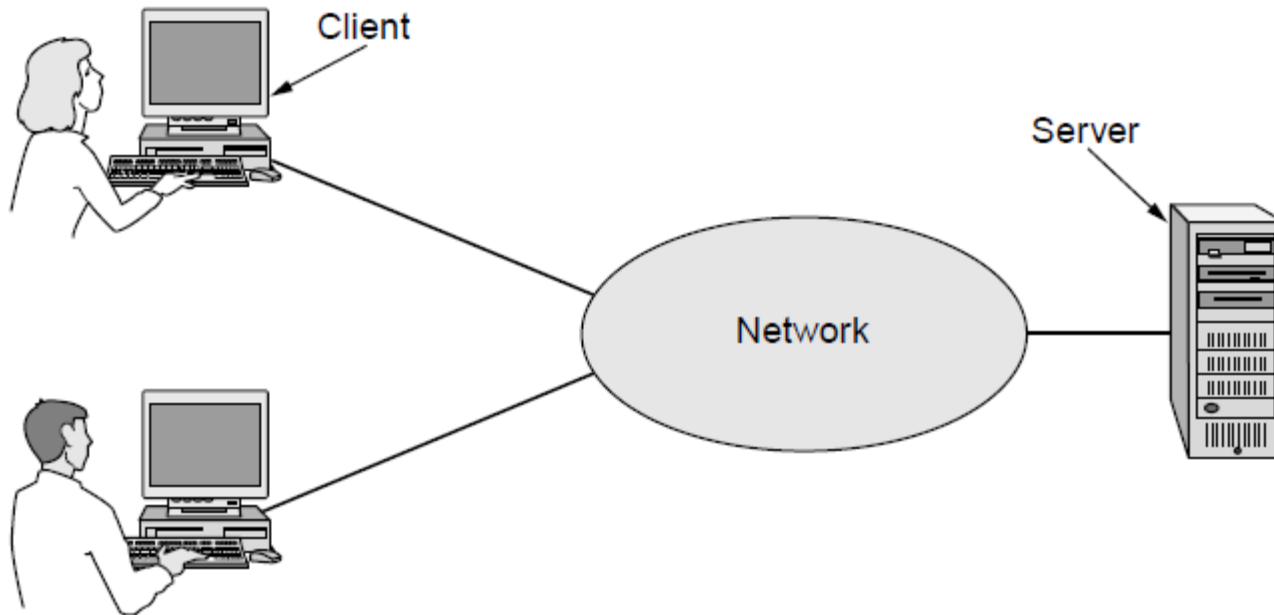

A network with two clients and one server

# Business Applications (2)

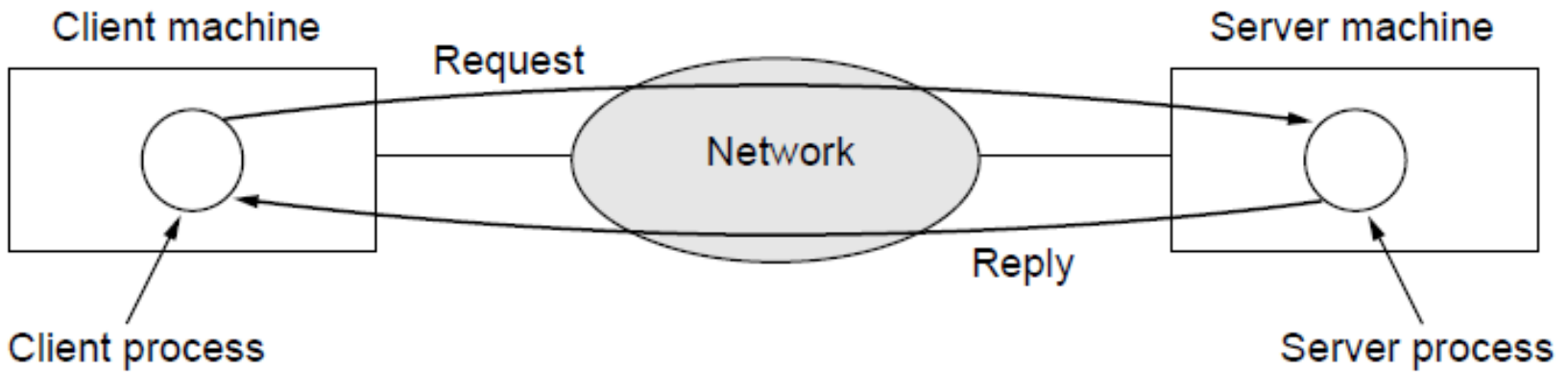

The client-server model involves requests and replies

# Home Applications (1)

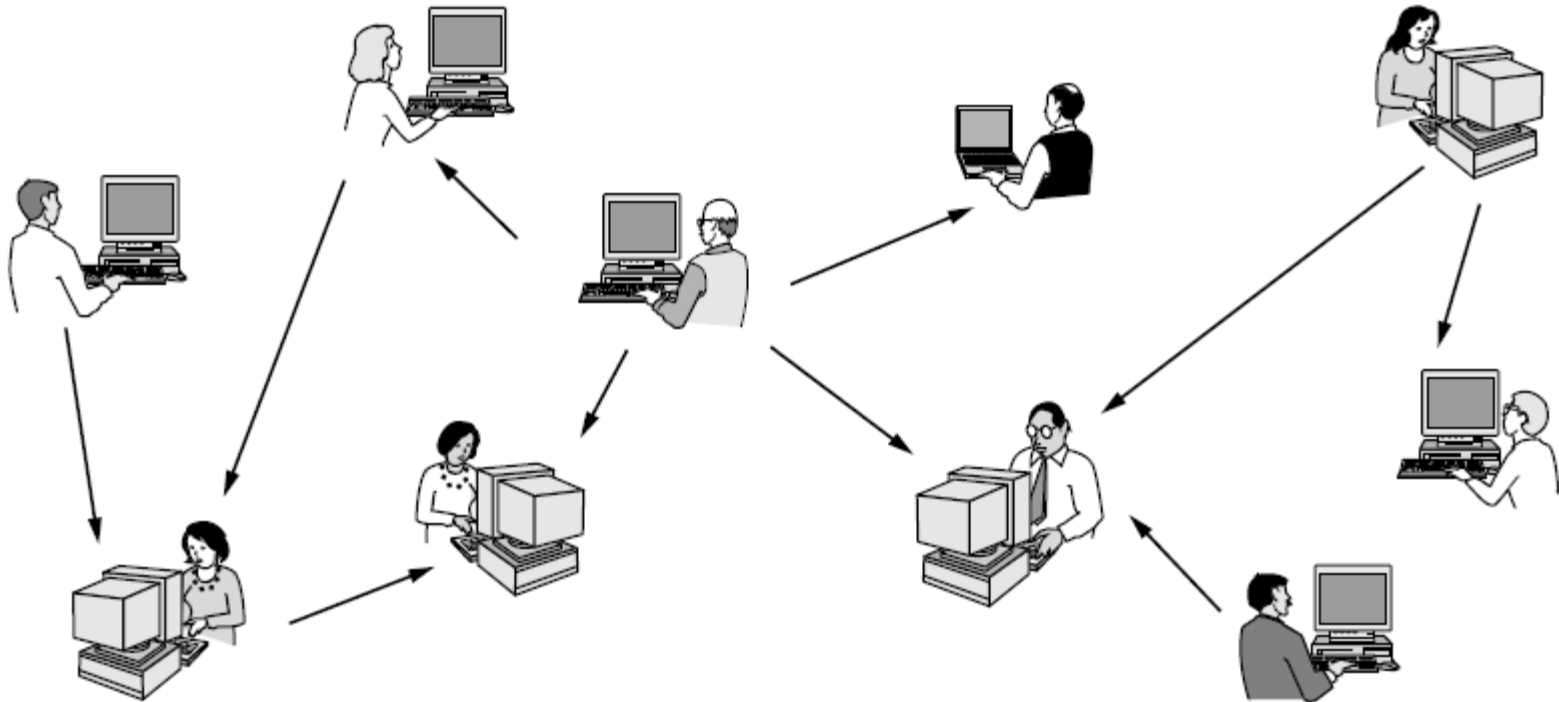

In a peer-to-peer system there are no fixed clients and servers.

# Home Applications (2)

<b>Tag</b>	<b>Full name</b>	<b>Example</b>
B2C	Business-to-consumer	Ordering books online
B2B	Business-to-business	Car manufacturer ordering tires from supplier
G2C	Government-to-consumer	Government distributing tax forms electronically
C2C	Consumer-to-consumer	Auctioning second-hand products online
P2P	Peer-to-peer	Music sharing

Some forms of e-commerce

# Mobile Users

<b>Wireless</b>	<b>Mobile</b>	<b>Typical applications</b>
No	No	Desktop computers in offices
No	Yes	A notebook computer used in a hotel room
Yes	No	Networks in unwired buildings
Yes	Yes	Store inventory with a handheld computer

Combinations of wireless networks and mobile computing

# Social Issues

- Network neutrality
- Digital Millennium Copyright Act
- Profiling users
- Phishing



# Network Hardware (1)

- Personal area networks
- Local area networks
- Metropolitan area networks
- Wide are networks
- The internet

# Network Hardware (2)

Interprocessor distance	Processors located in same	Example
1 m	Square meter	Personal area network
10 m	Room	Local area network
100 m	Building	
1 km	Campus	
10 km	City	Metropolitan area network
100 km	Country	Wide area network
1000 km	Continent	
10,000 km	Planet	The Internet

Classification of interconnected processors by scale.

# Personal Area Network

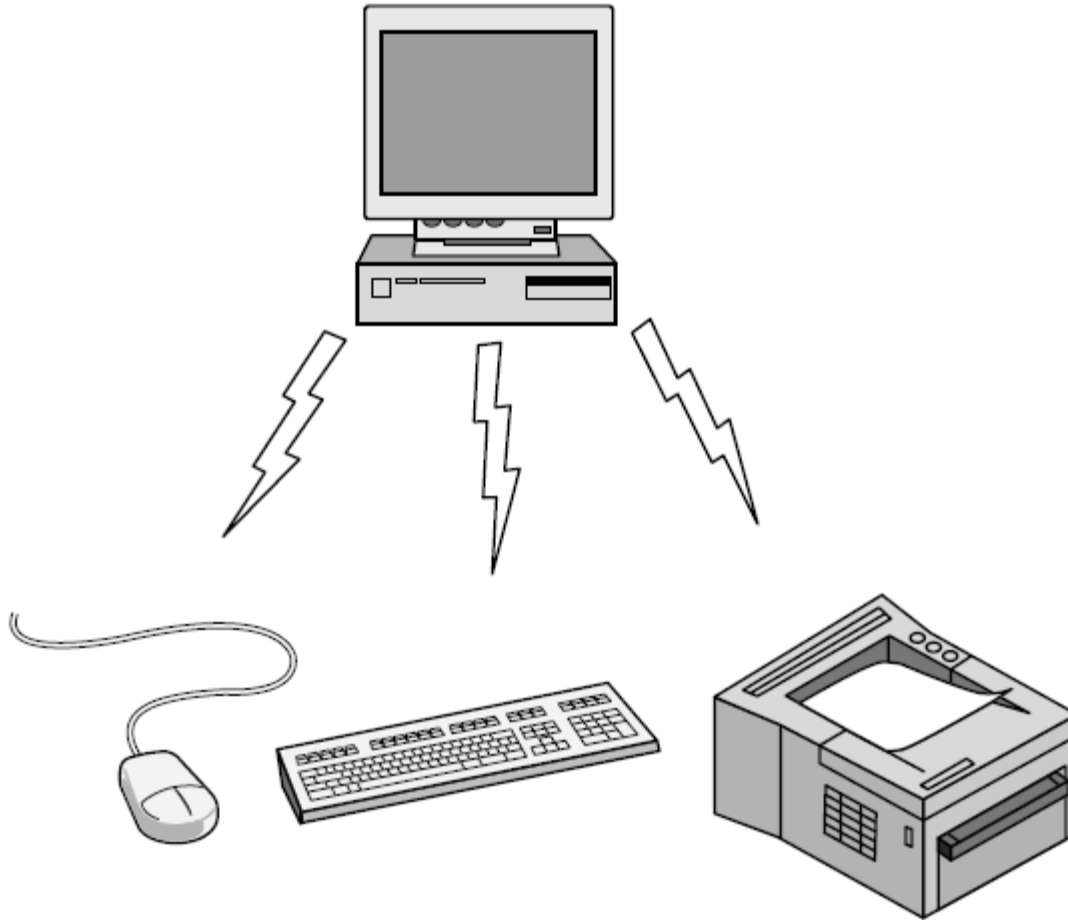

Bluetooth PAN configuration

# Local Area Networks

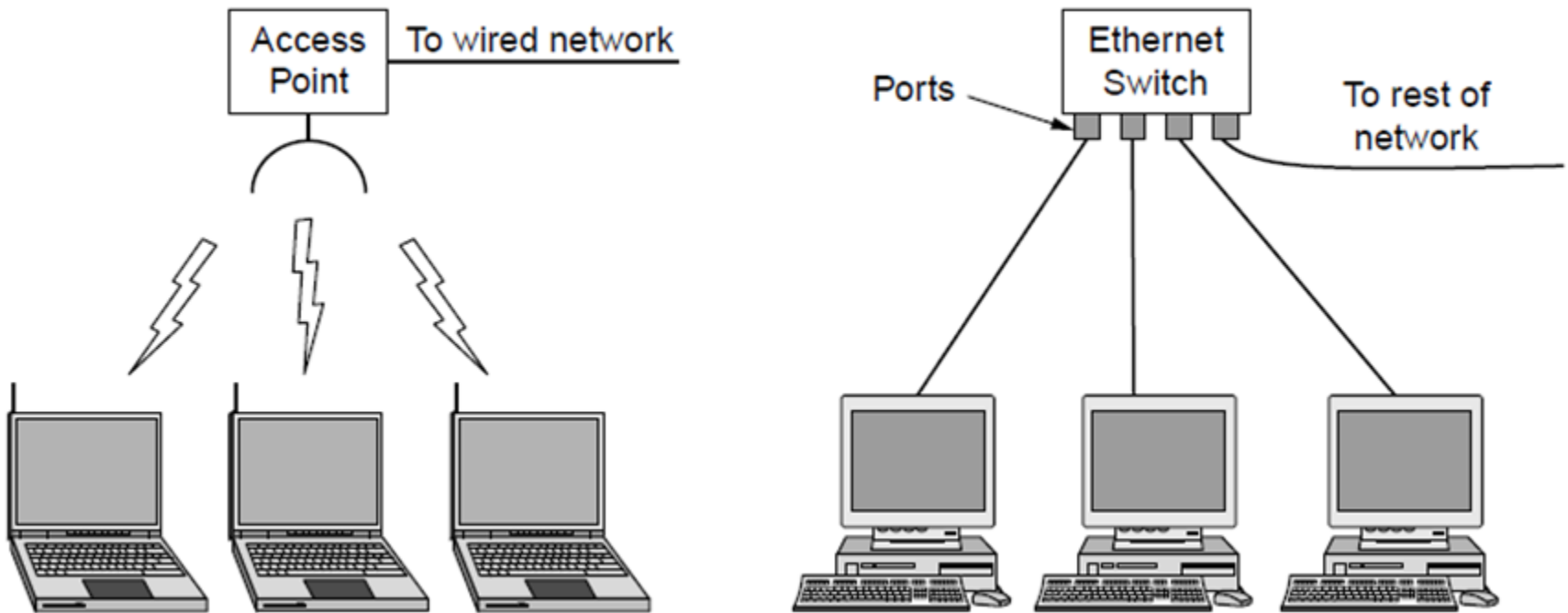

Wireless and wired LANs. (a) 802.11. (b) Switched Ethernet.

# Metropolitan Area Networks

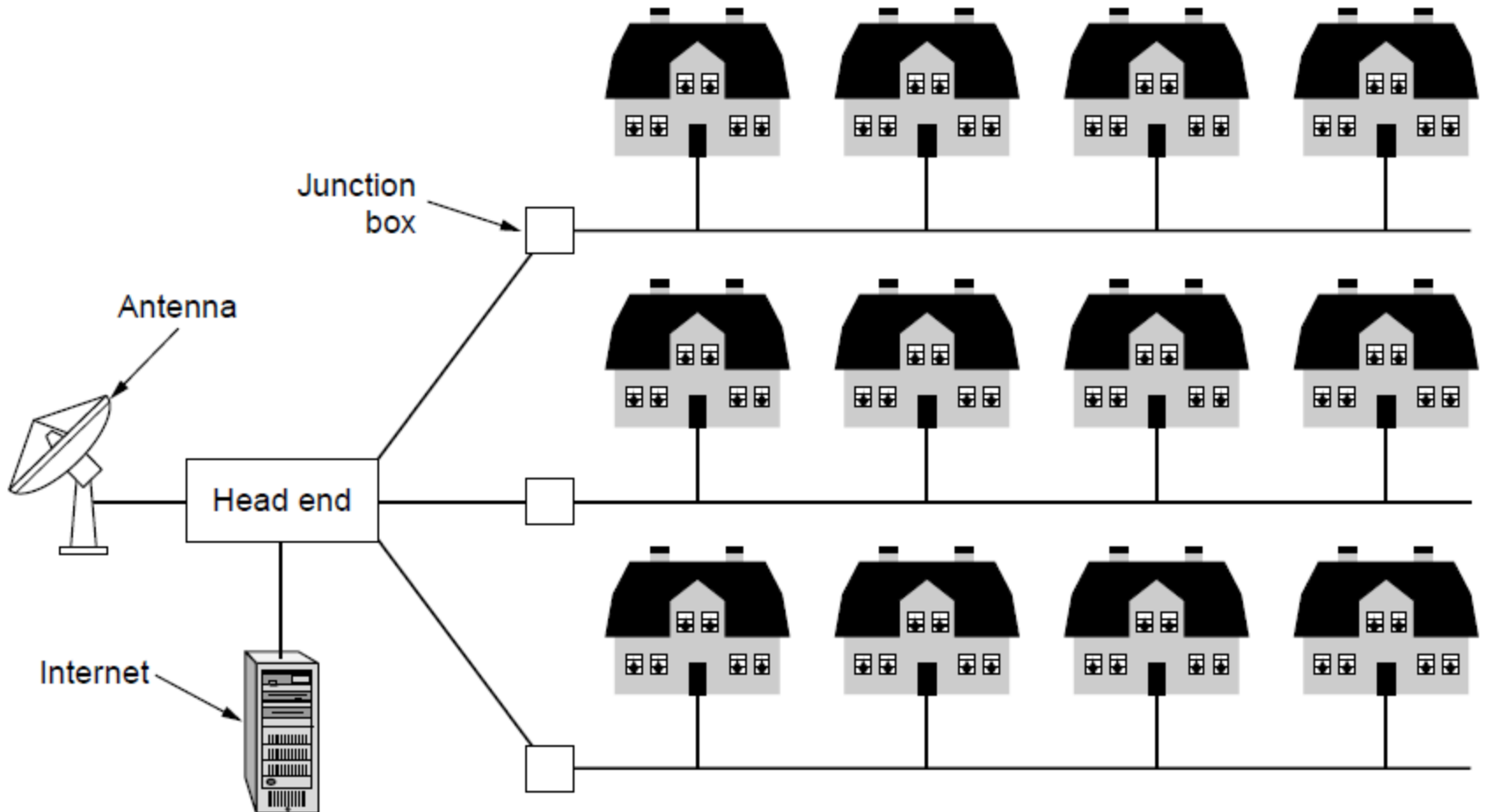

A metropolitan area network based on cable TV.

# Wide Area Networks (1)

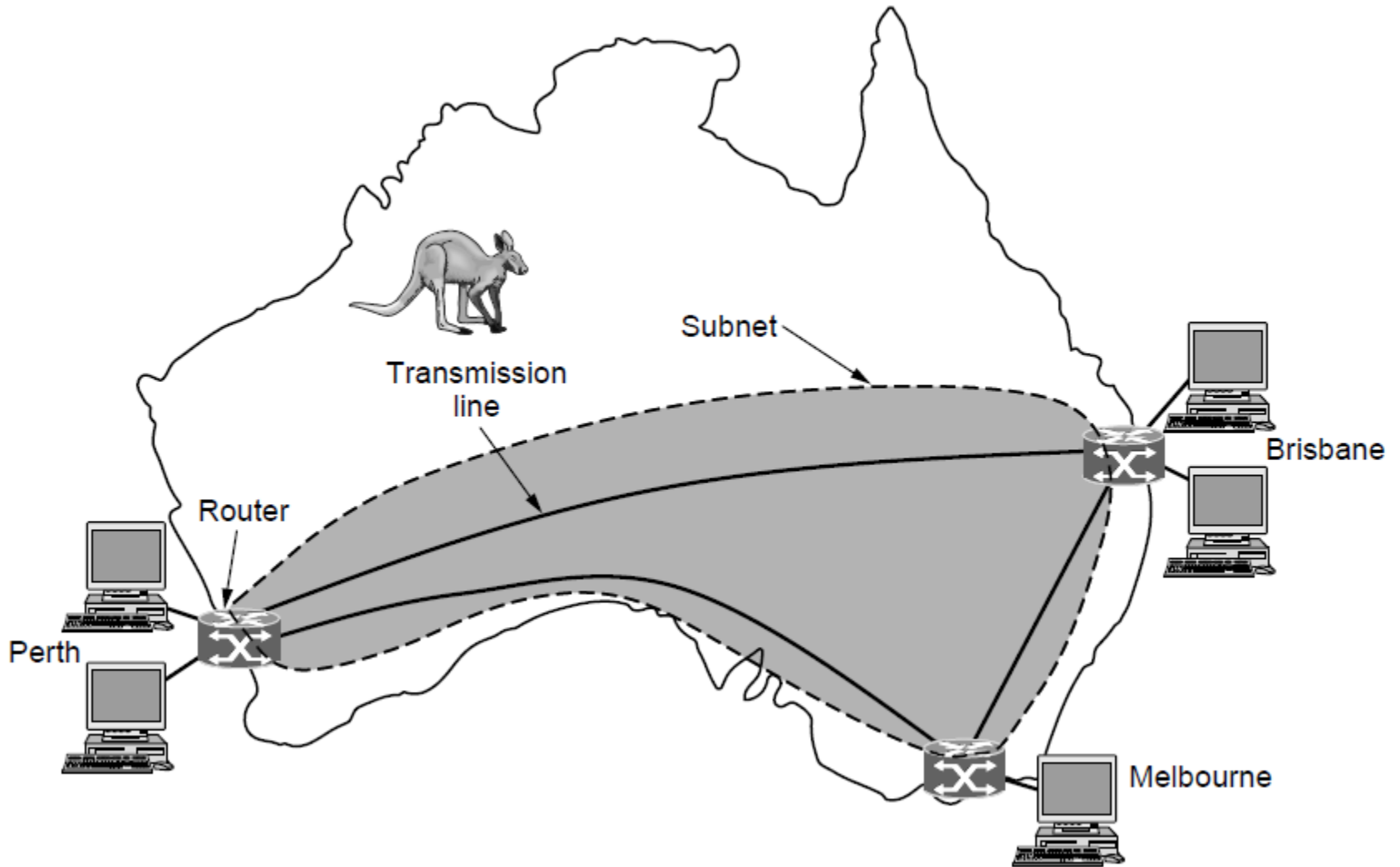

WAN that connects three branch offices in Australia

# Wide Area Networks (2)

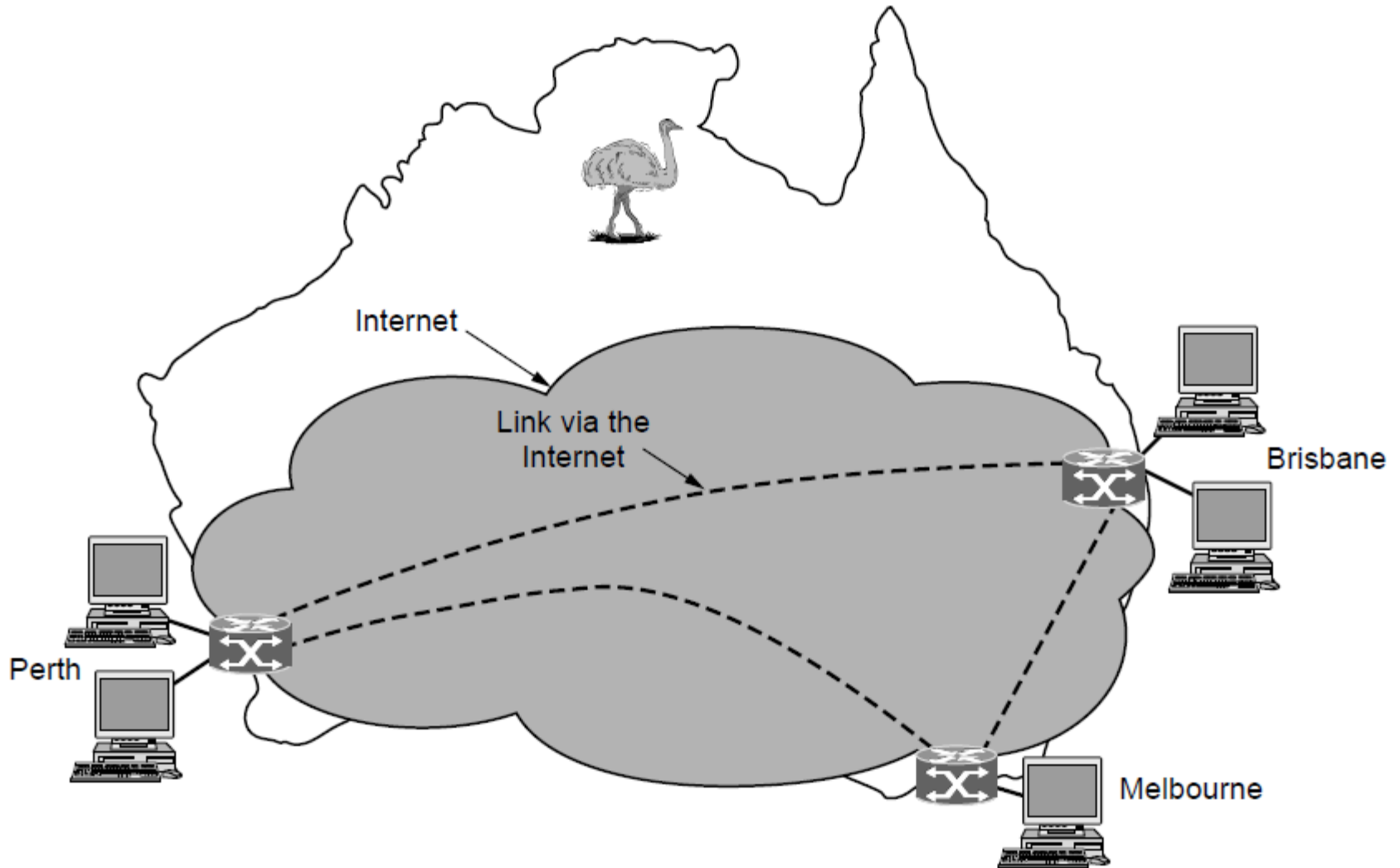

WAN using a virtual private network.

# Wide Area Networks (3)

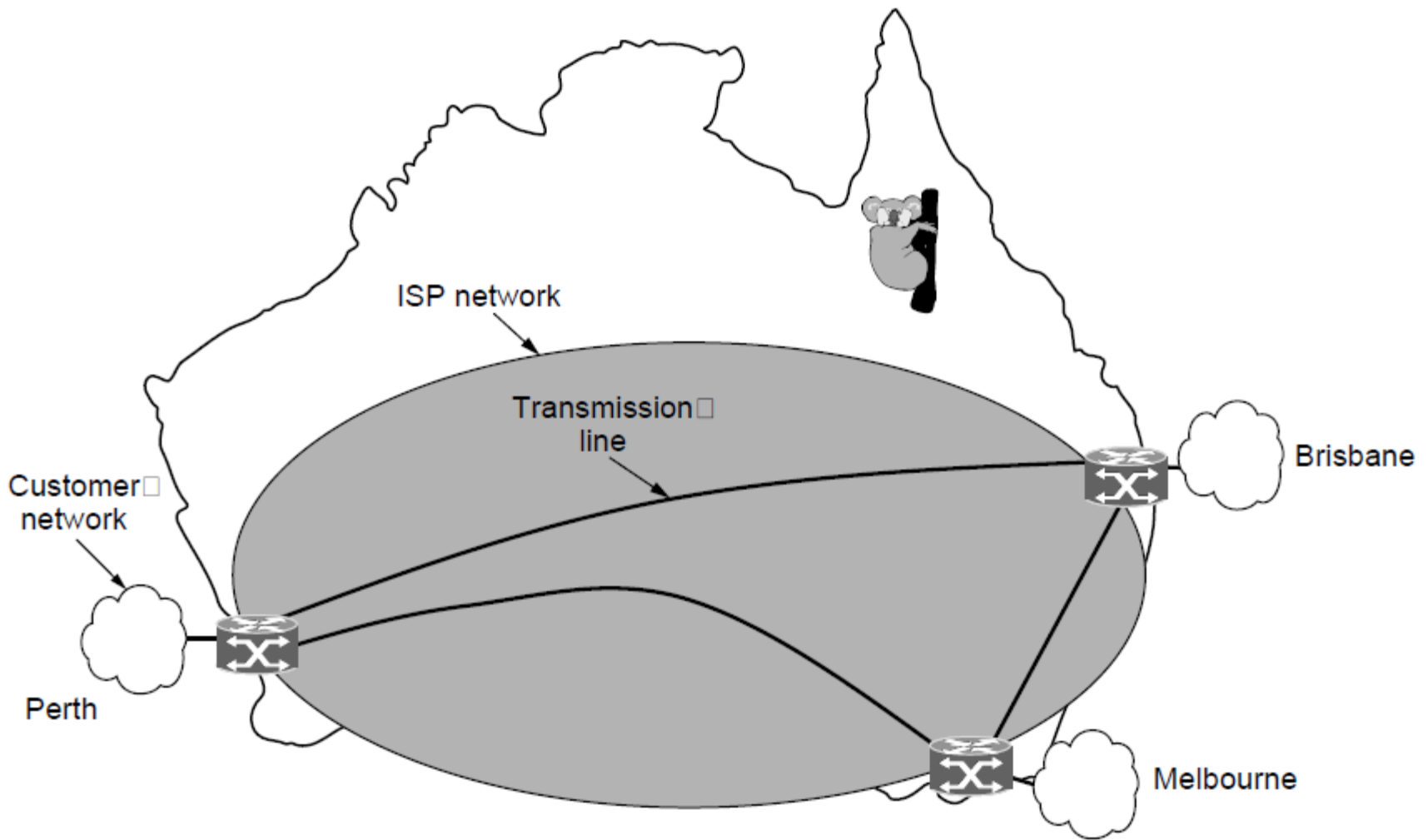

WAN using an ISP network.



# Network Software

- Protocol hierarchies
- Design issues for the layers
- Connection-oriented versus connectionless service
- Service primitives
- Relationship of services to protocols

# Protocol Hierarchies (1)

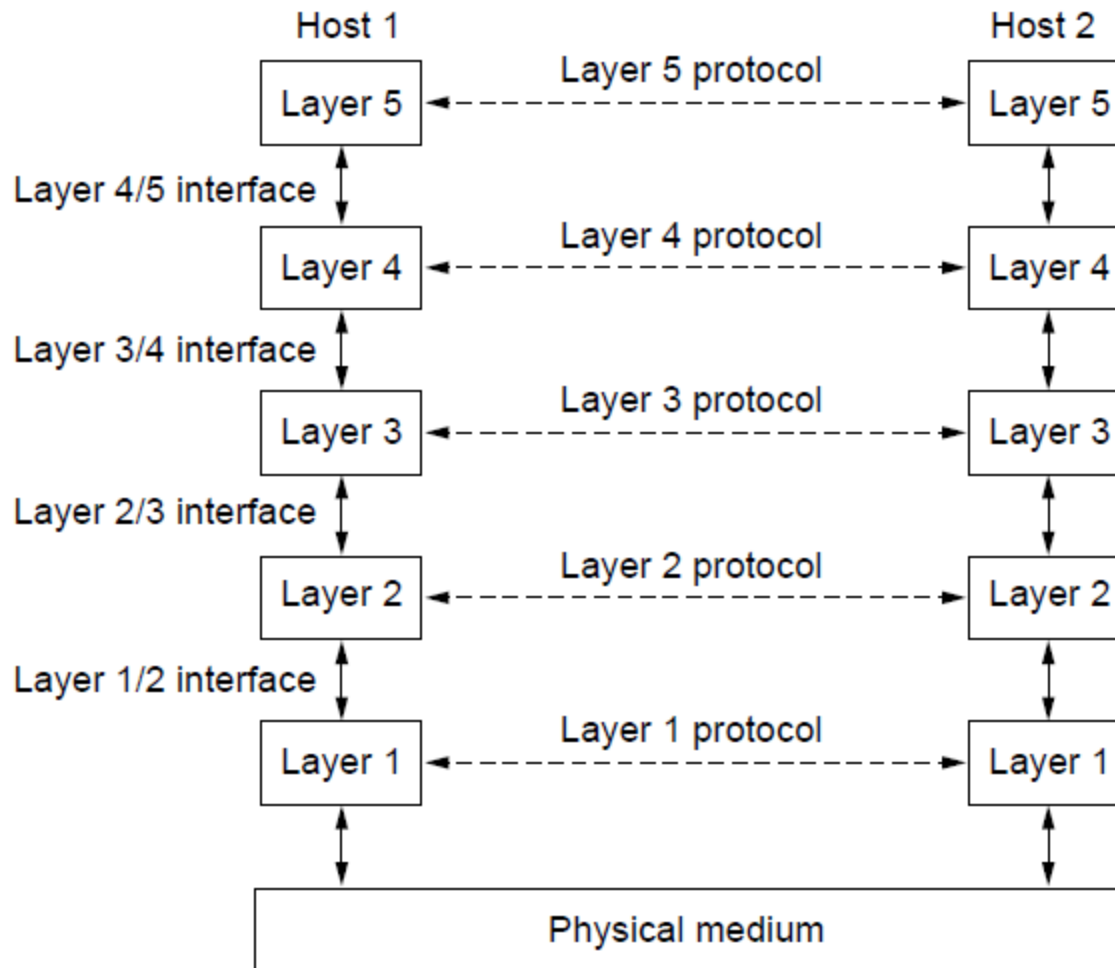

Layers, protocols, and interfaces.

# Protocol Hierarchies (2)

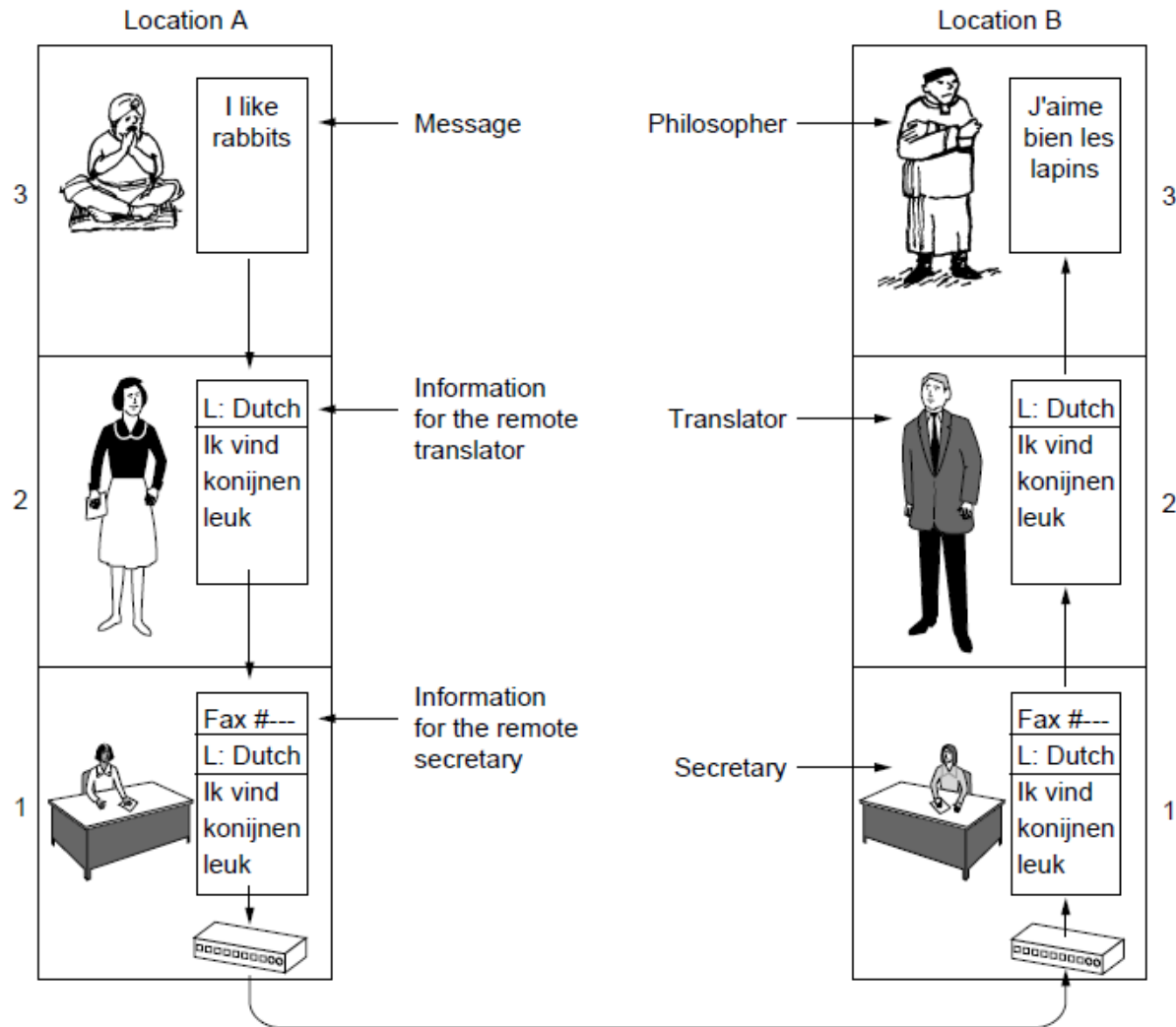

The philosopher-translator-secretary architecture

# Protocol Hierarchies (3)

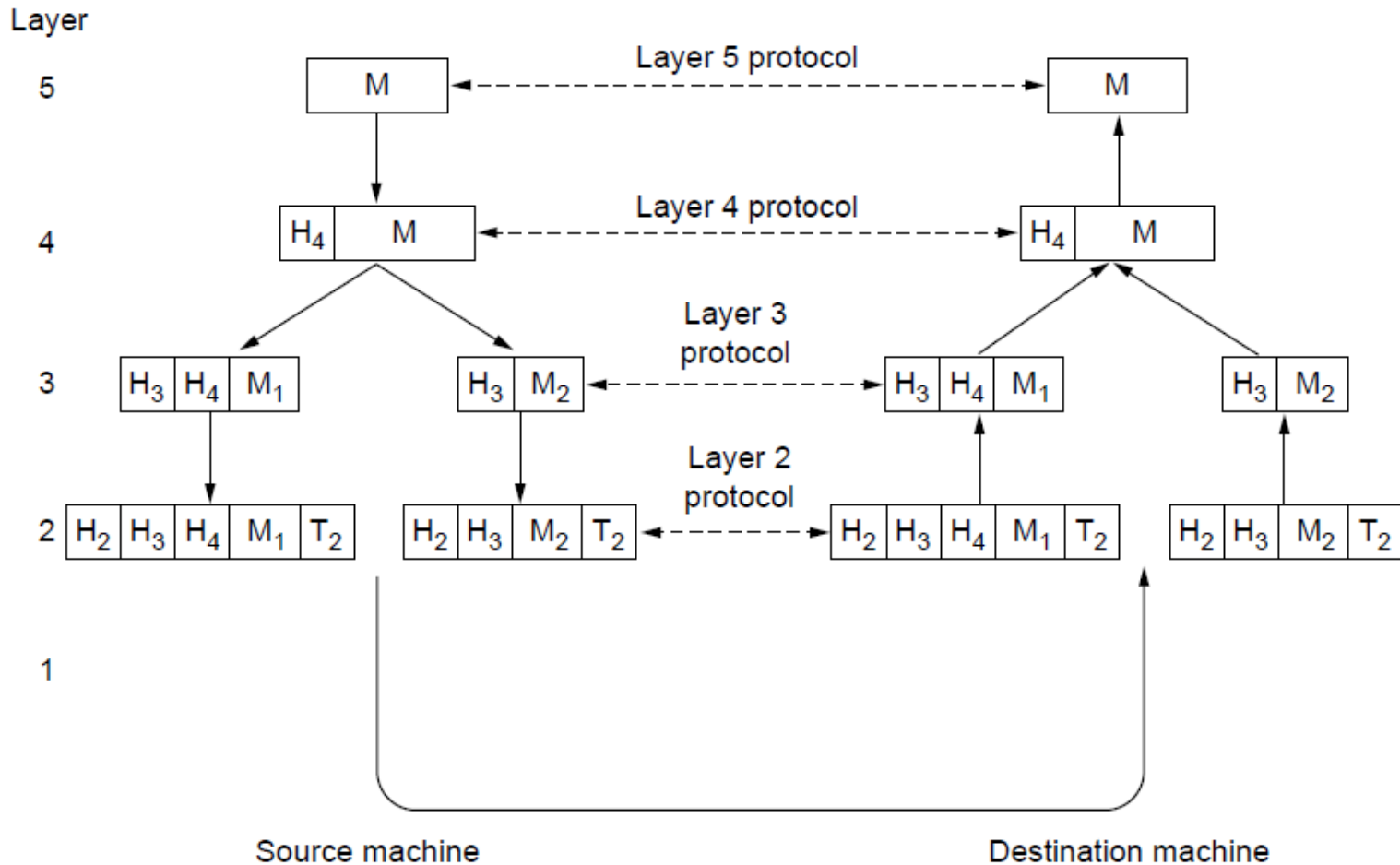

Example information flow supporting virtual communication in layer 5.

# Connection-Oriented Versus Connectionless Service

	Service	Example
Connection-oriented	Reliable message stream	Sequence of pages
	Reliable byte stream	Movie download
	Unreliable connection	Voice over IP
Connection-less	Unreliable datagram	Electronic junk mail □
	Acknowledged datagram	Text messaging
	Request-reply	Database query

Six different types of service.

# Service Primitives (1)

<b>Primitive</b>	<b>Meaning</b>
LISTEN	Block waiting for an incoming connection
CONNECT	Establish a connection with a waiting peer
ACCEPT	Accept an incoming connection from a peer
RECEIVE	Block waiting for an incoming message
SEND	Send a message to the peer
DISCONNECT	Terminate a connection

Six service primitives that provide a simple connection-oriented service

# Service Primitives (2)

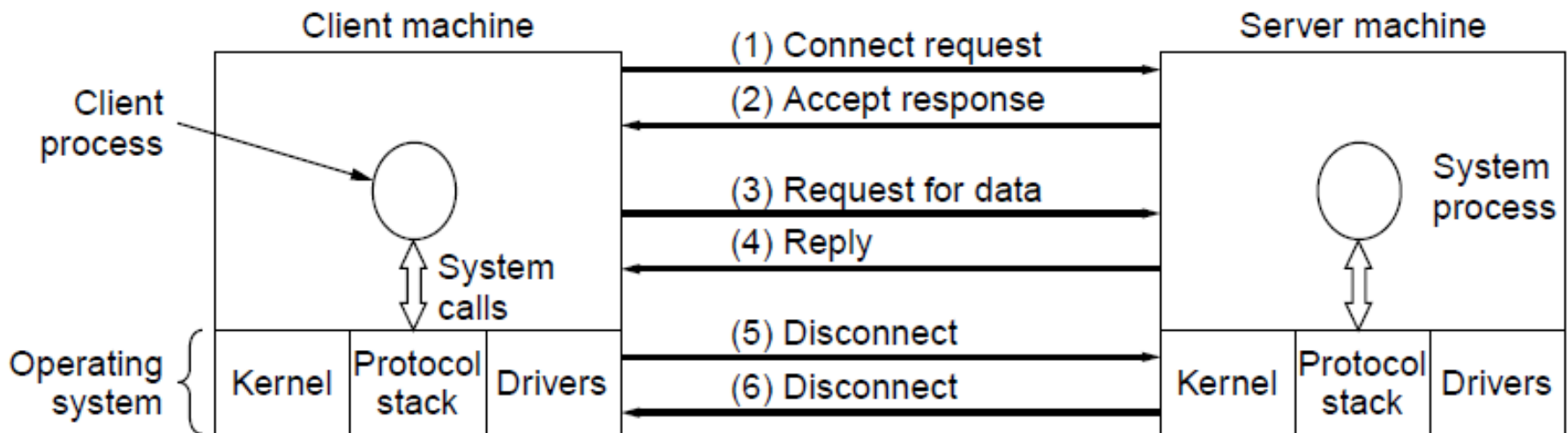

A simple client-server interaction using acknowledged datagrams.

# The Relationship of Services to Protocols

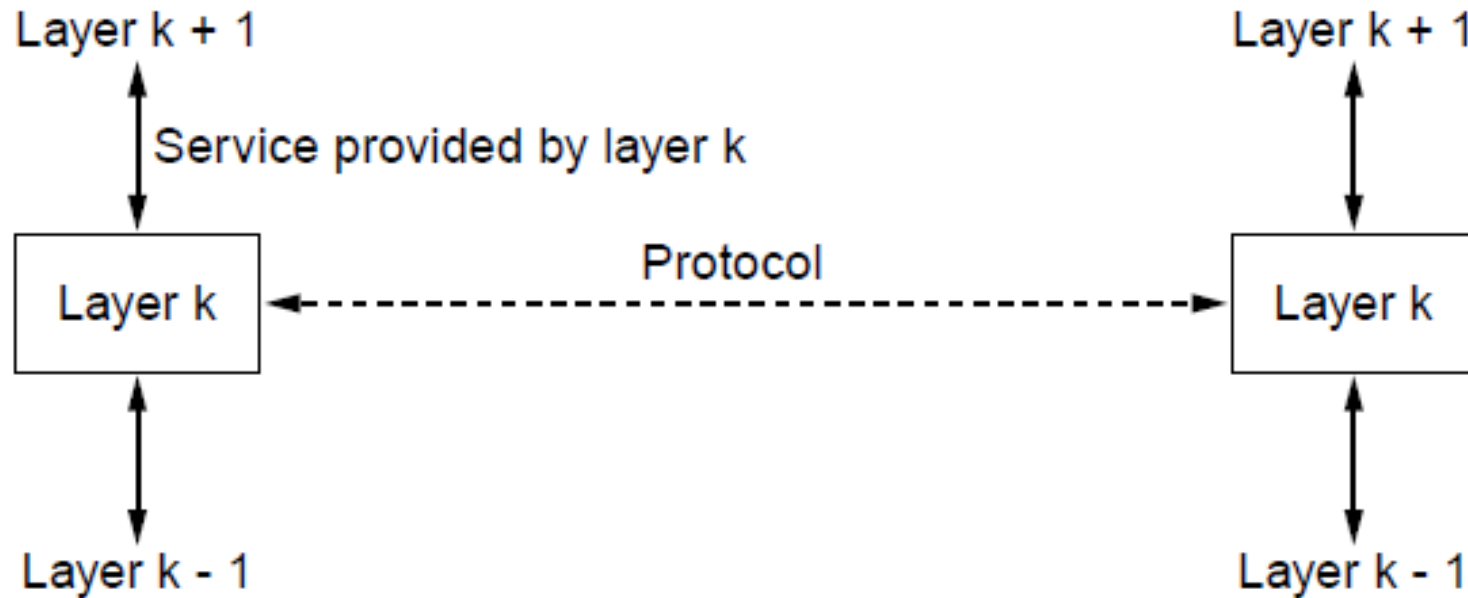

The relationship between a service and a protocol.



# Reference Models

- OSI reference model
- TCP/IP reference model
- Model used for this text
- Comparison of OSI and TCP/IP
- Critique of OSI model and protocols
- Critique of TCP/IP model

# The OSI Reference Model

## Principles for the seven layers

- Layers created for different abstractions
- Each layer performs well-defined function
- Function of layer chosen with definition of international standard protocols in mind
- Minimize information flow across interfaces between boundaries
- Number of layers optimum

# The OSI Reference Model

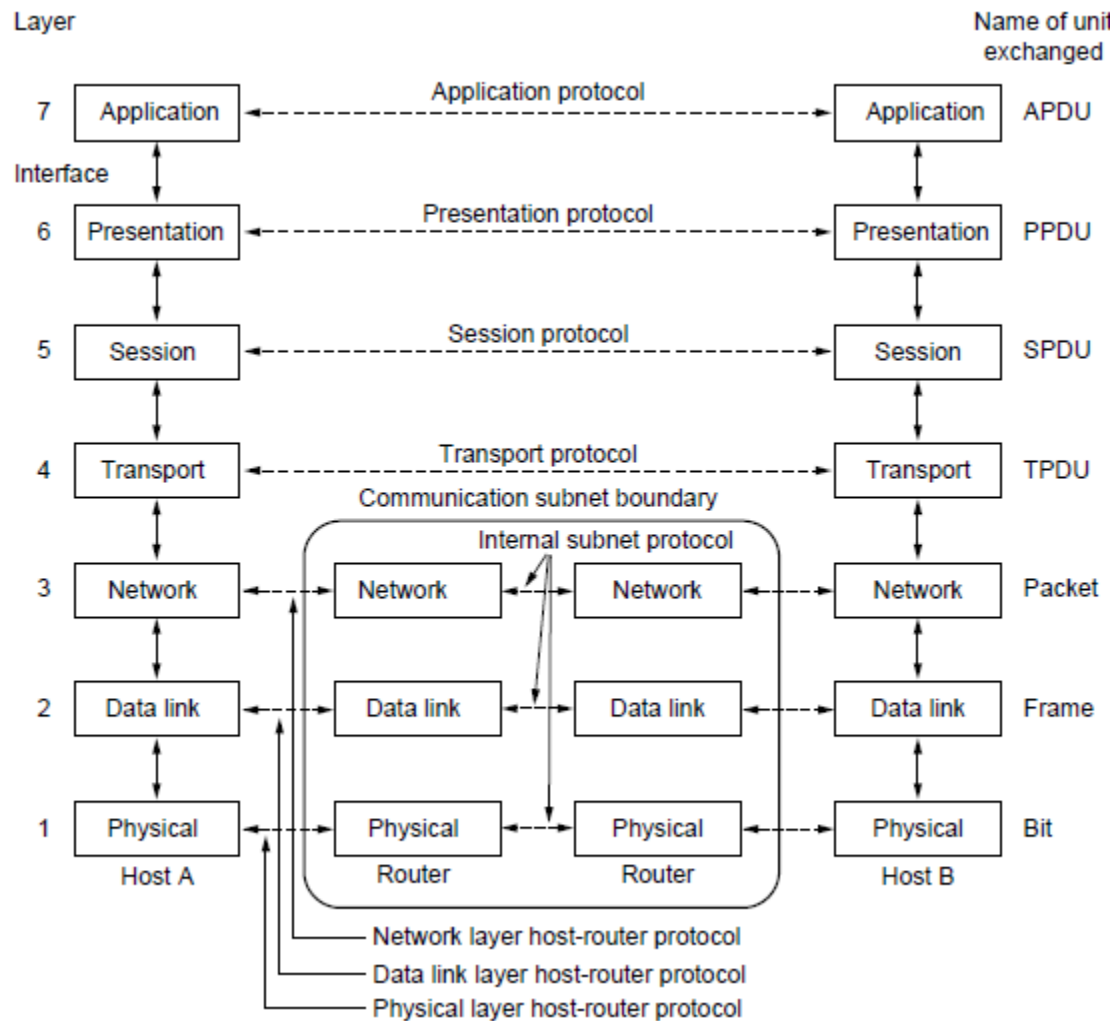

The OSI reference model

# OSI Reference Model Layers

- Physical layer
- Data link layer
- Network layer
- Transport layer
- Session layer
- Presentation layer
- Application layer

# The TCP/IP Reference Model Layers

- Link layer
- Internet layer
- Transport layer
- Application layer

# The TCP/IP Reference Model (1)

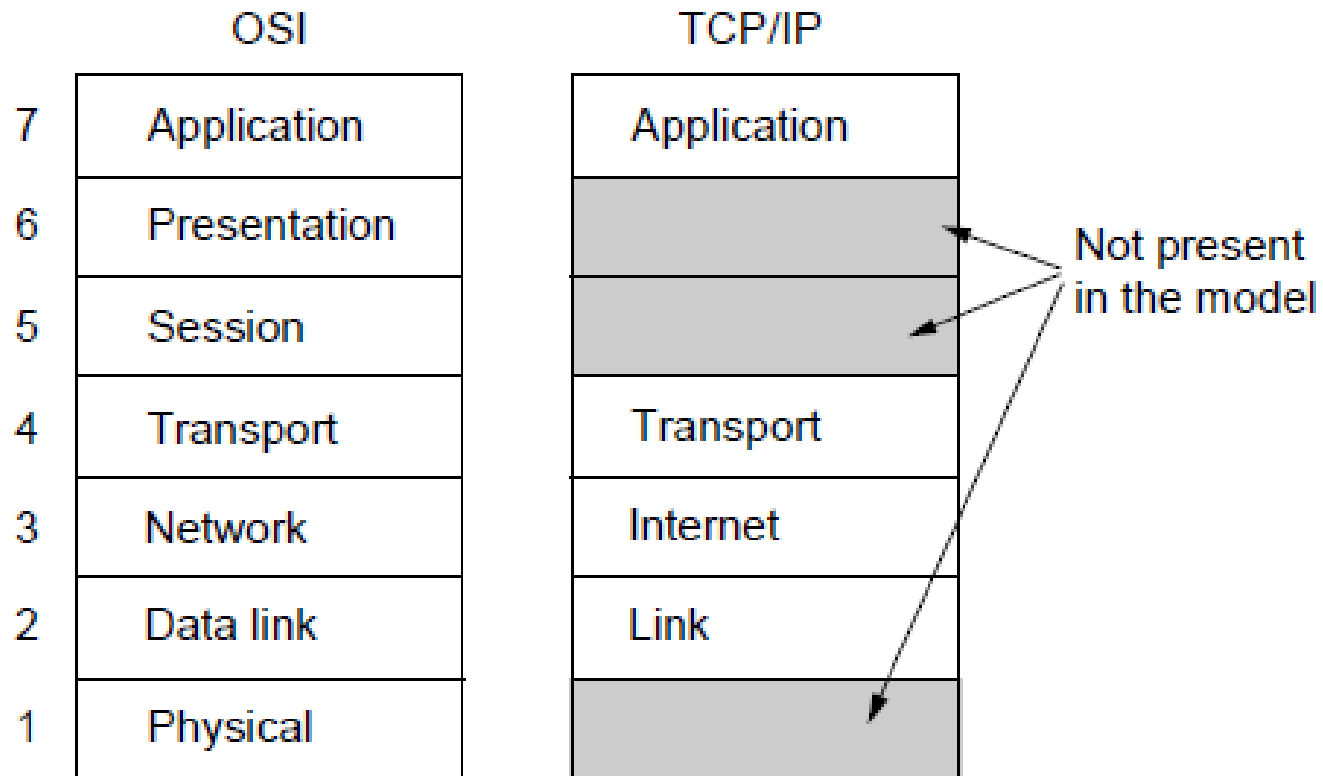

The TCP/IP reference model

# The TCP/IP Reference Model (2)

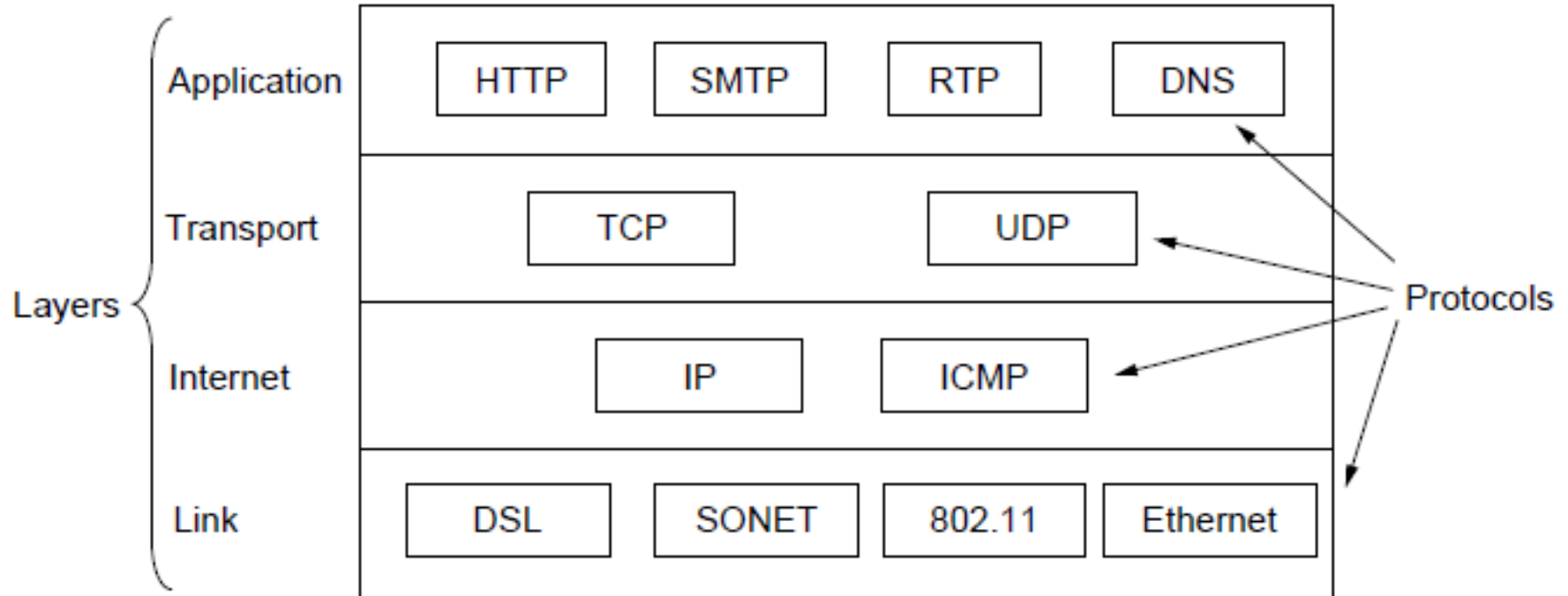

The TCP/IP reference model with some protocols we will study

# The Model Used in this Book

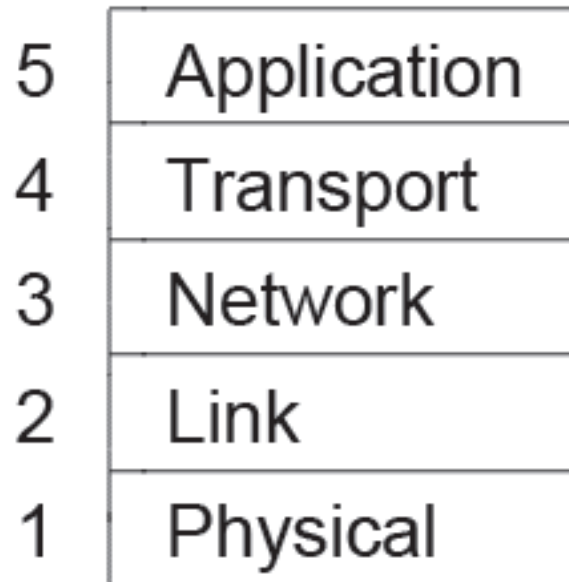

The reference model used in this book.



# Comparison of the OSI and TCP/IP Reference Models

## Concepts central to OSI model

- Services
- Interfaces
- Protocols

# Critique of the OSI Model and Protocols

- Bad timing.
- Bad technology.
- Bad implementations.
- Bad politics.

# OSI Model Bad Timing

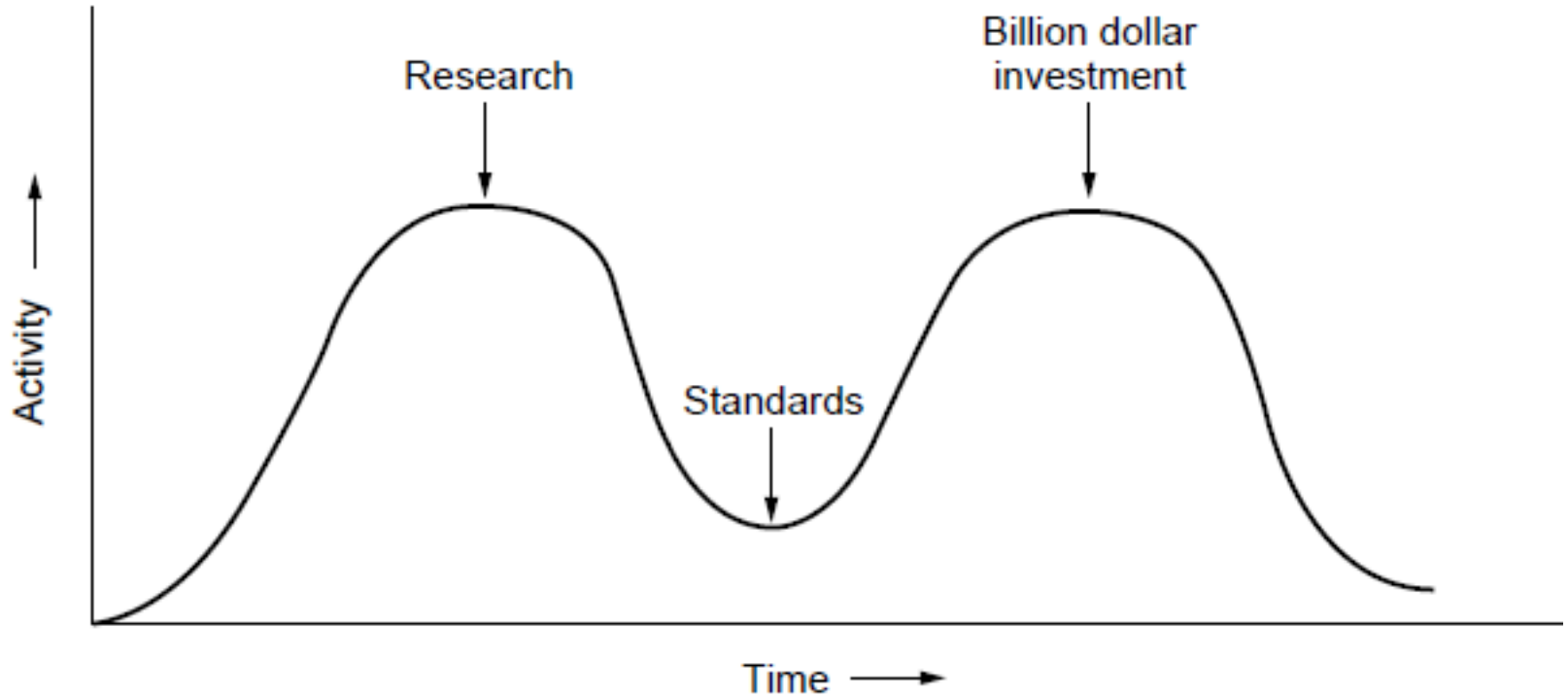

The apocalypse of the two elephants.

# Example Networks

- Internet
- ARPANET
- NSFNET
- Third-generation mobile phone networks
- Wireless LANs: 802.11
- RFID and sensor networks

# The ARPANET (1)

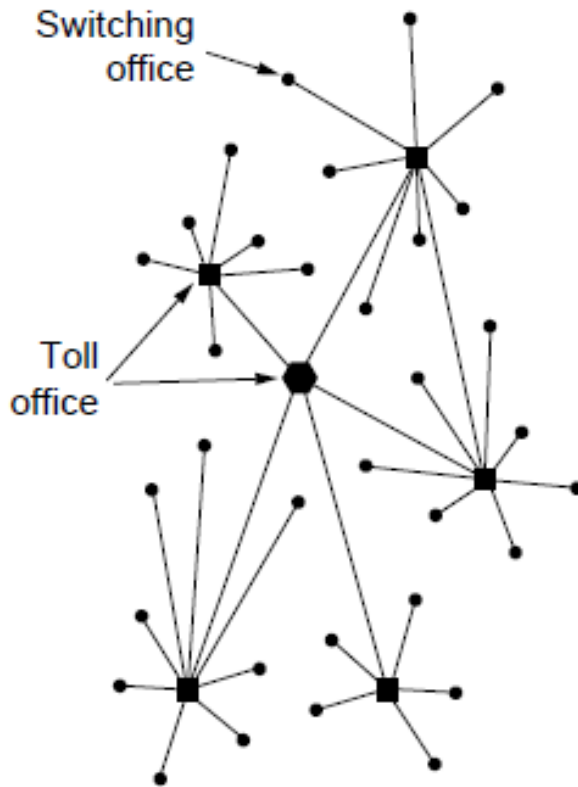

(a)

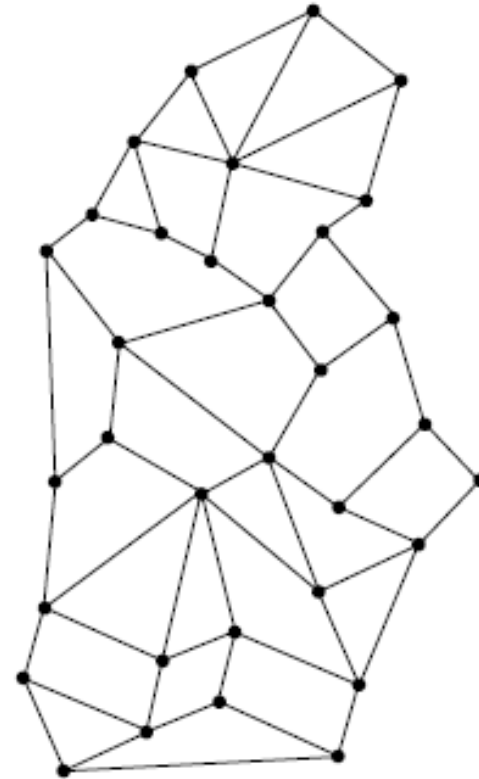

(b)

- a) Structure of the telephone system.
- b) Baran's proposed distributed switching system.

# The ARPANET (2)

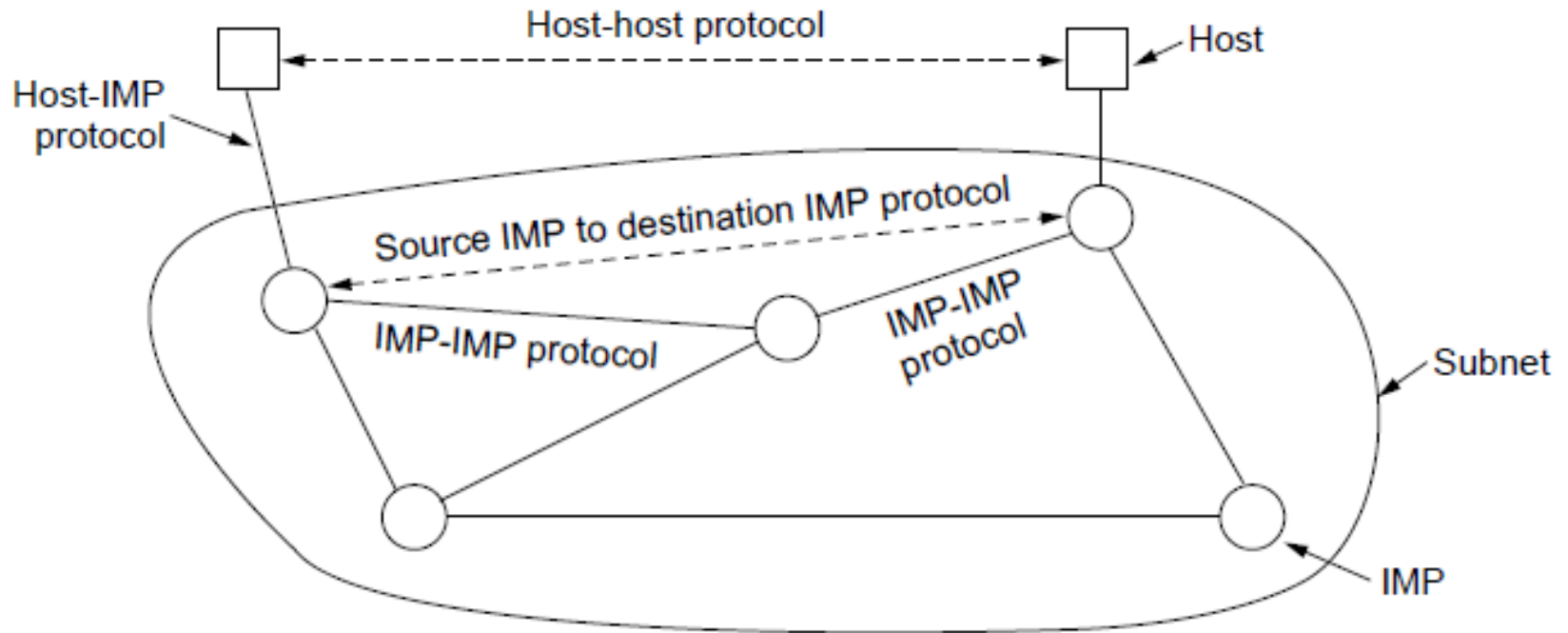

The original ARPANET design

# The ARPANET (3)

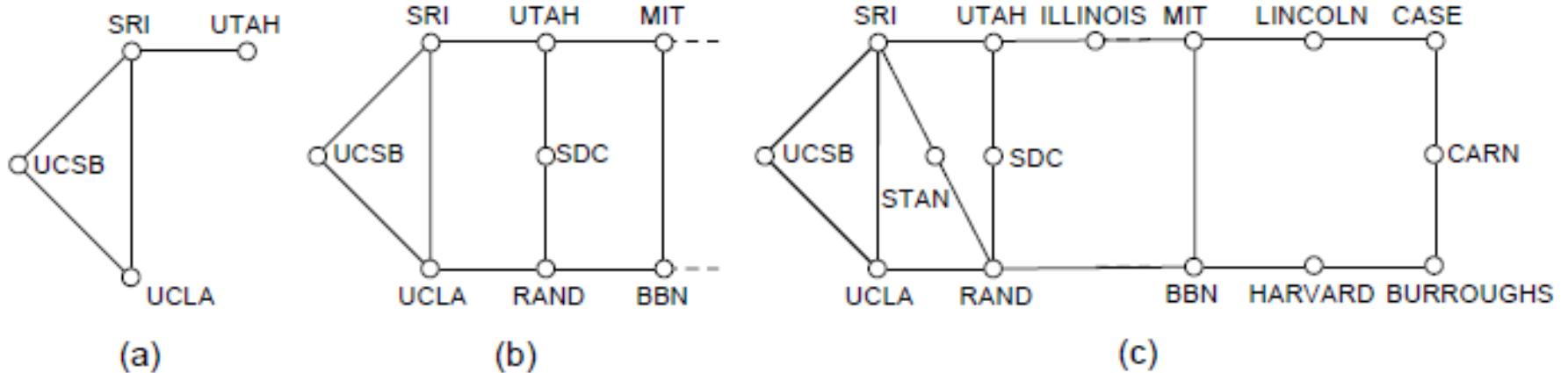

Growth of the ARPANET.

- a) December 1969.
- b) July 1970.
- c) March 1971.

# The ARPANET (4)

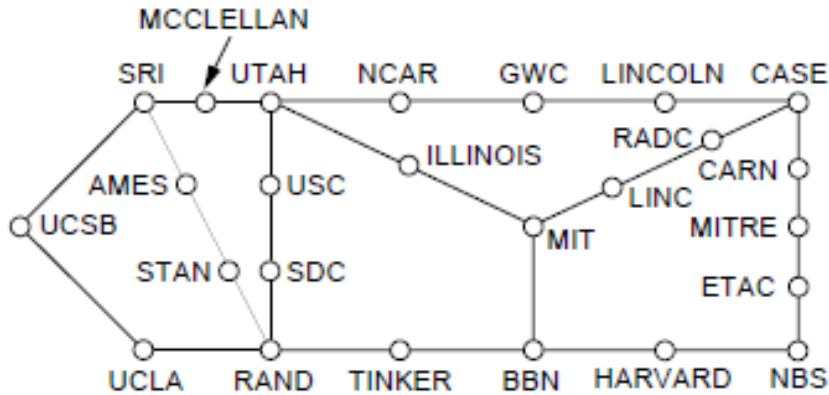

(d)

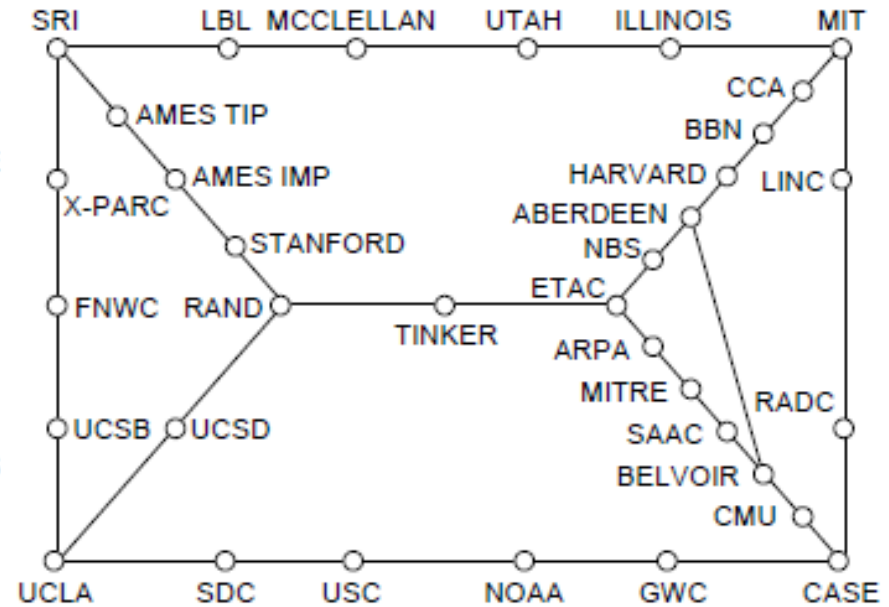

(e)

Growth of the ARPANET.

d) April 1972.

e) September 1972.



# NSFNET

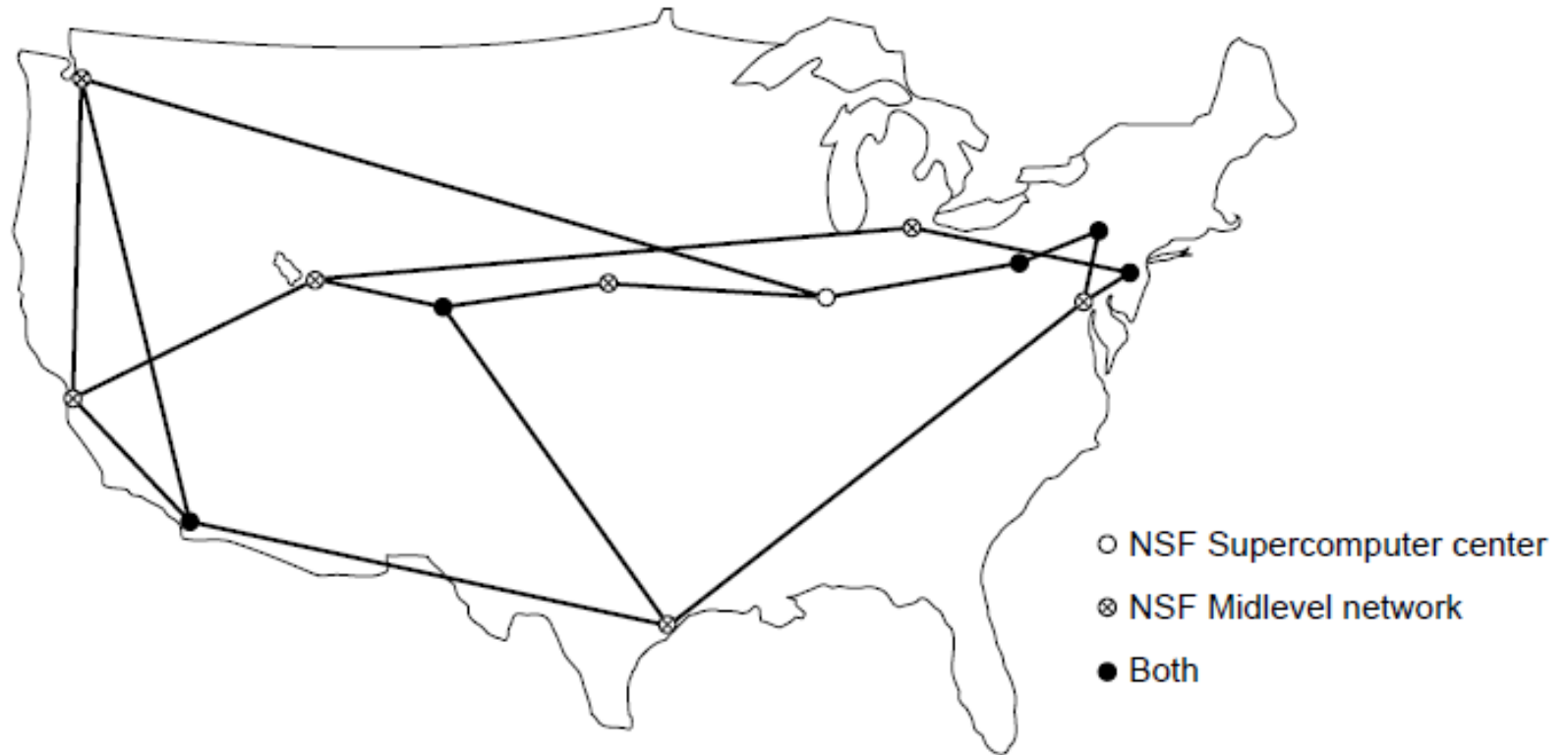

The NSFNET backbone in 1988.

# Architecture of the Internet

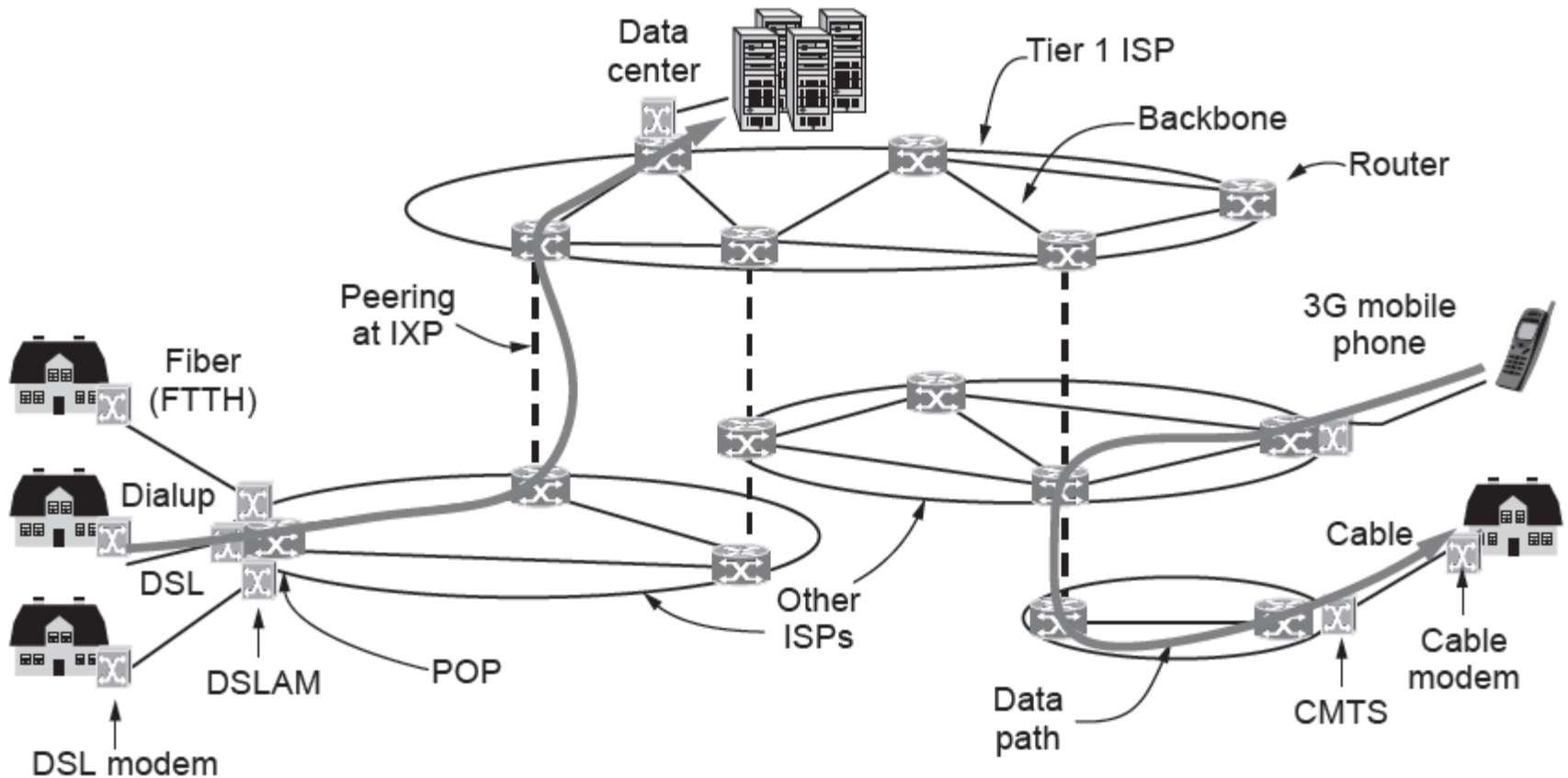

Overview of the Internet architecture

# Third-Generation Mobile Phone Networks (1)

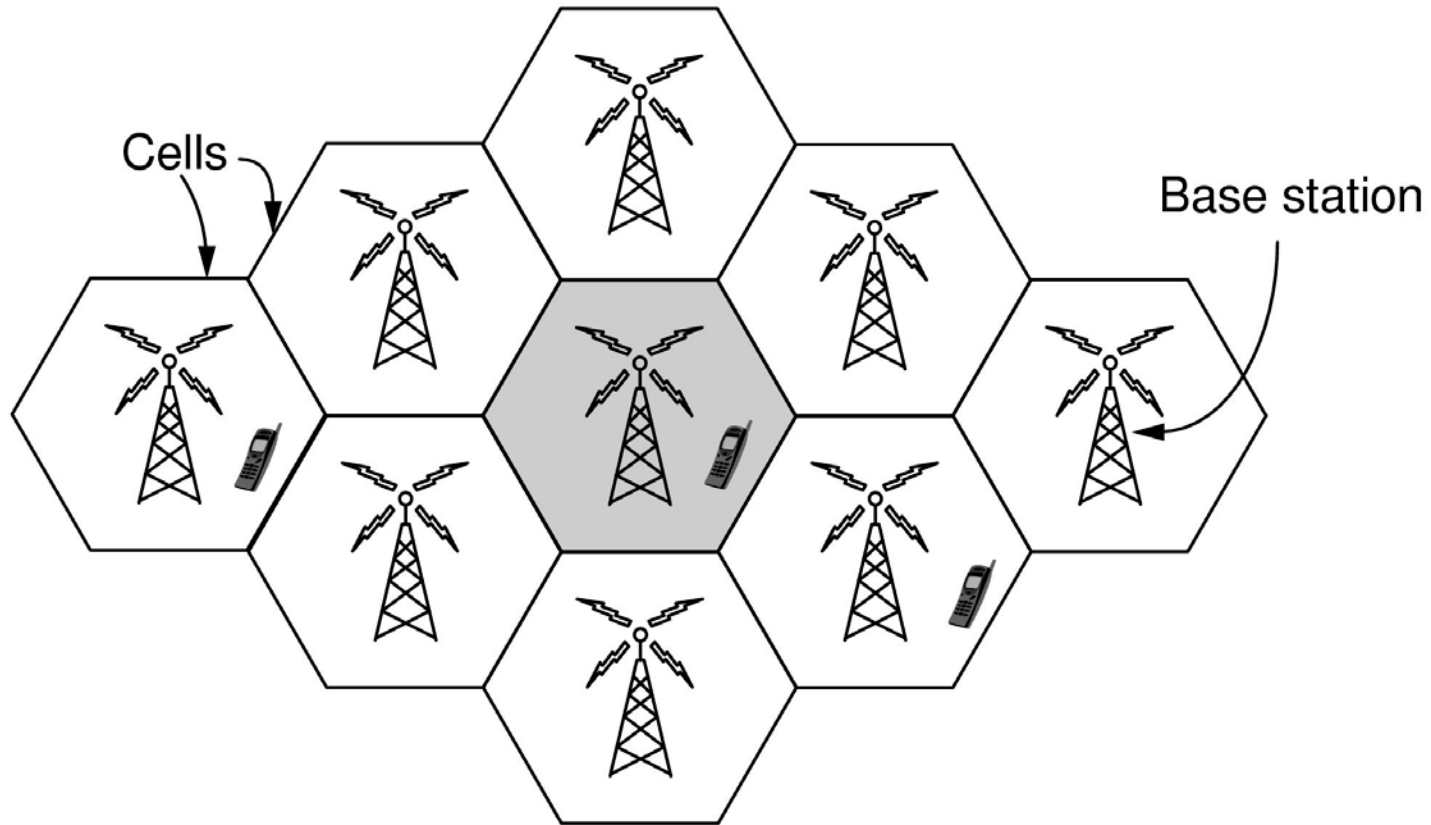

Cellular design of mobile phone networks

# Third-Generation Mobile Phone Networks (2)

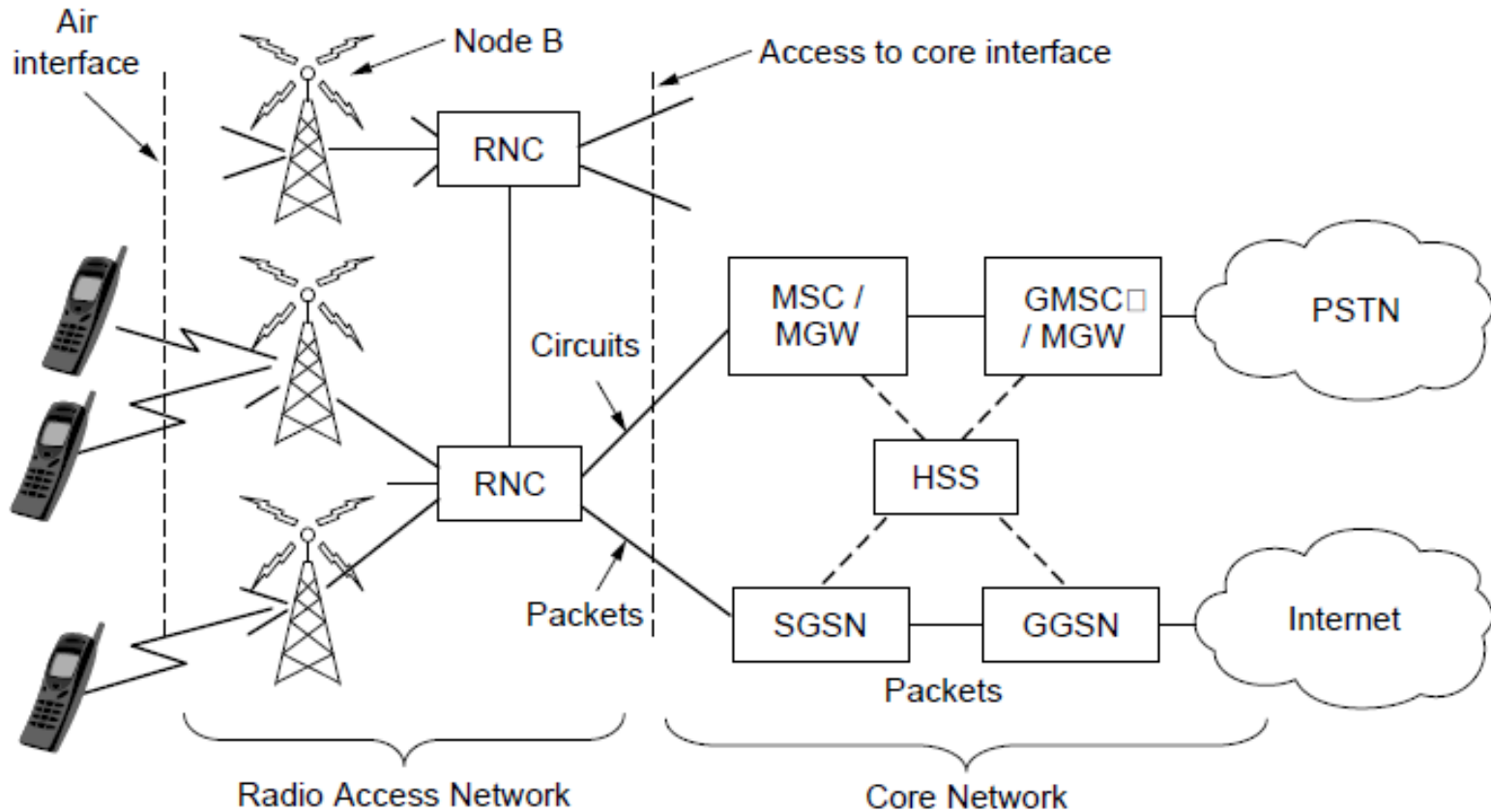

Architecture of the UMTS 3G mobile phone network.

# Third-Generation Mobile Phone Networks (3)

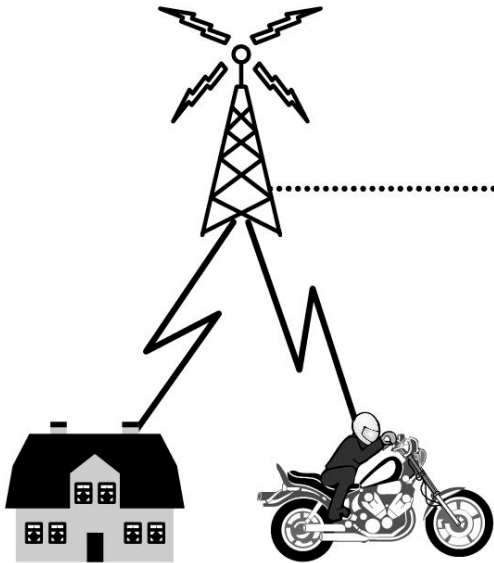

(a)

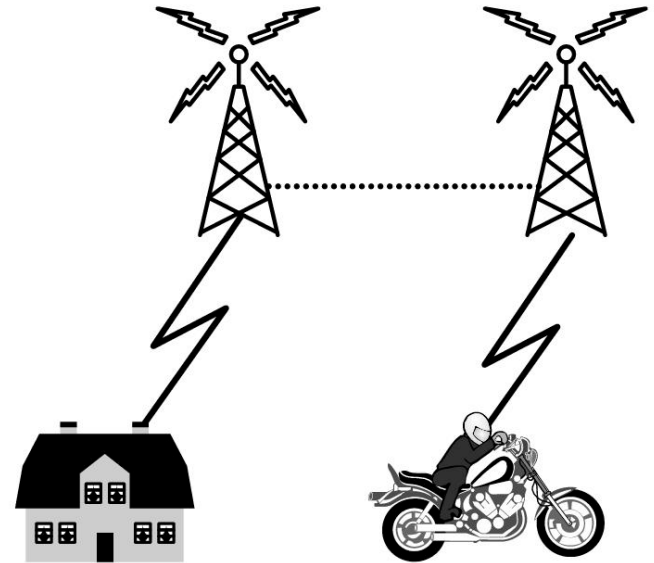

(b)

Mobile phone handover (a) before, (b) after.

# Wireless LANs: 802.11 (1)

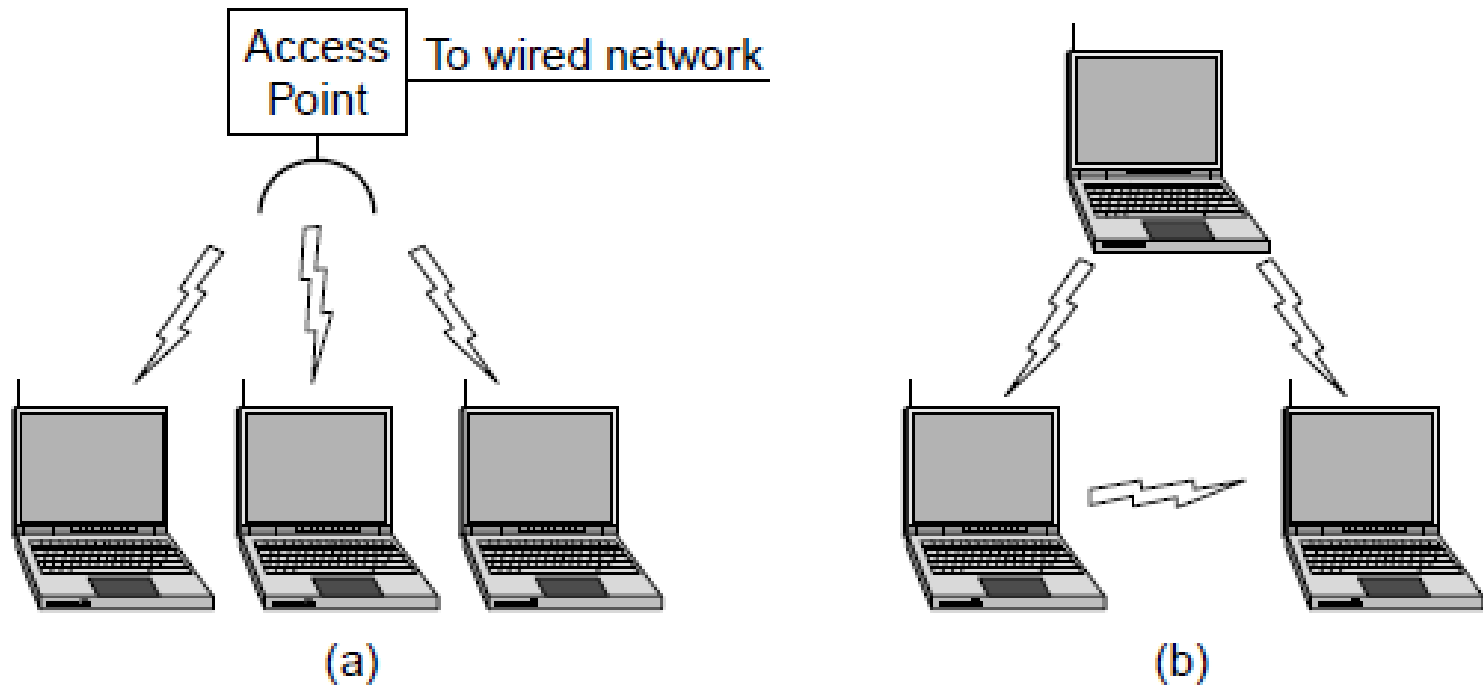

- (a) Wireless network with an access point.
- (b) Ad hoc network.

# Wireless LANs: 802.11 (2)

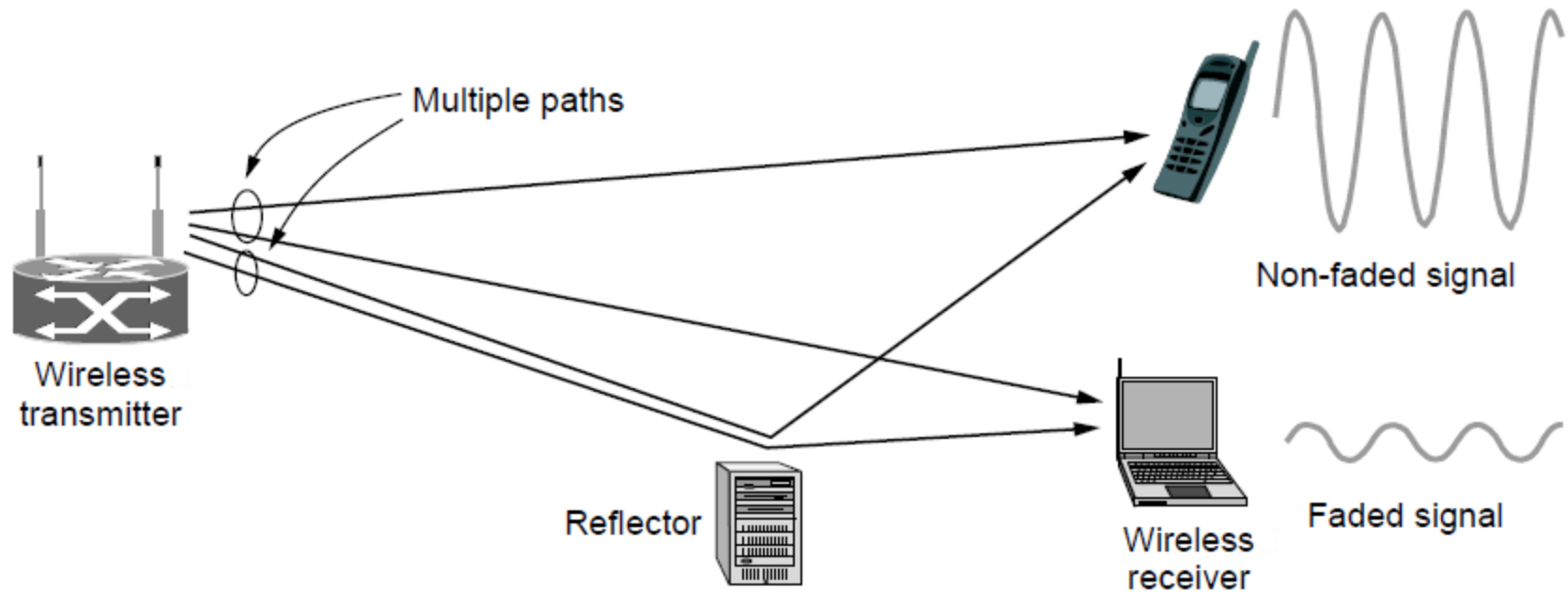

Multipath fading

# Wireless LANs: 802.11 (3)

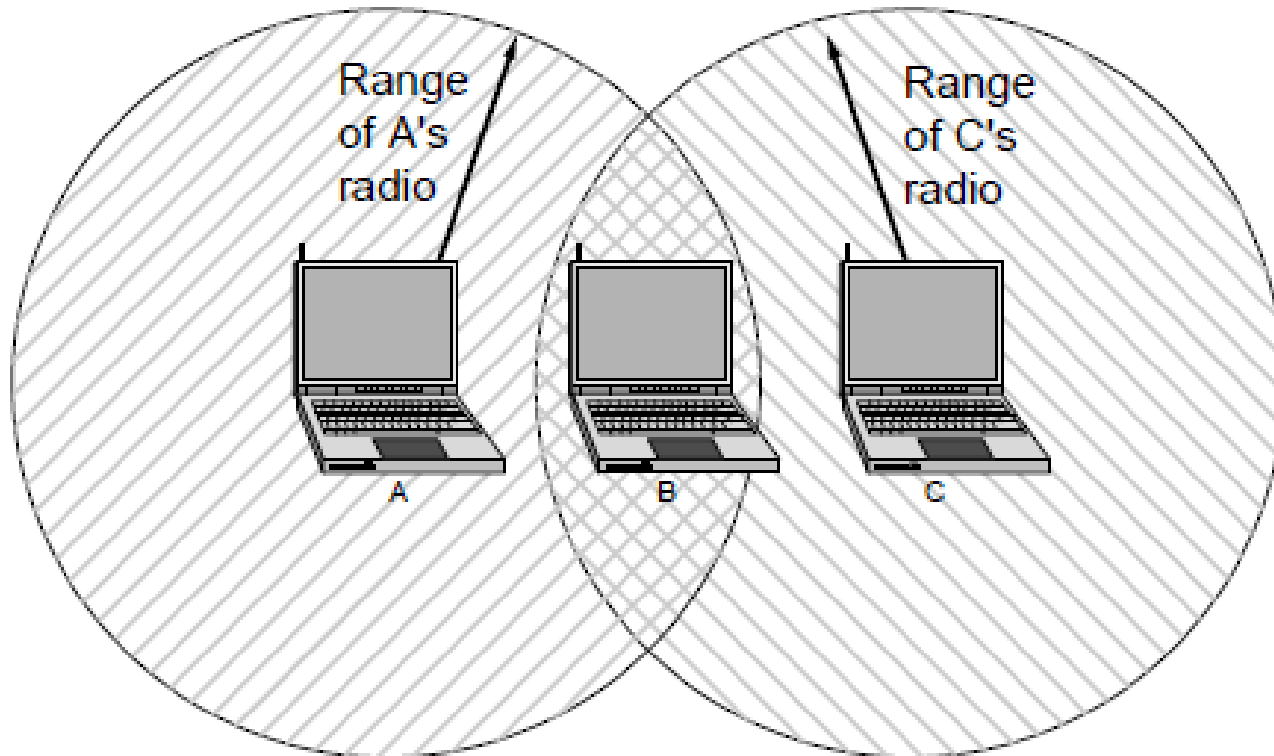

The range of a single radio may not cover the entire system.



# RFID and Sensor Networks (1)

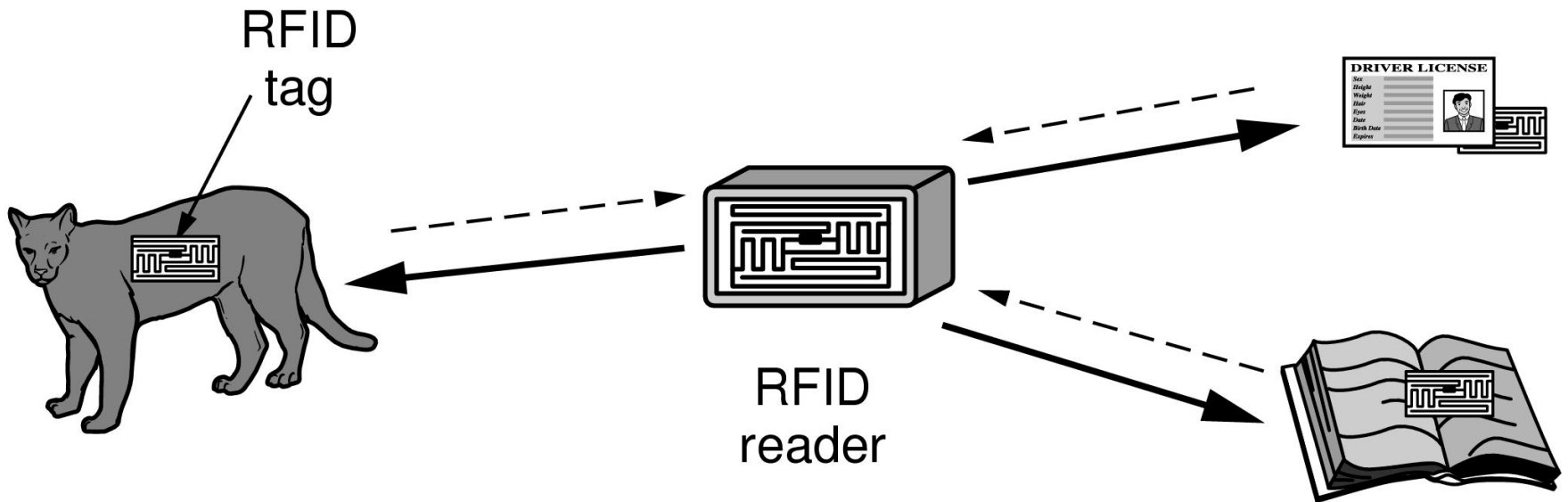

RFID used to network everyday objects.

# RFID and Sensor Networks (2)

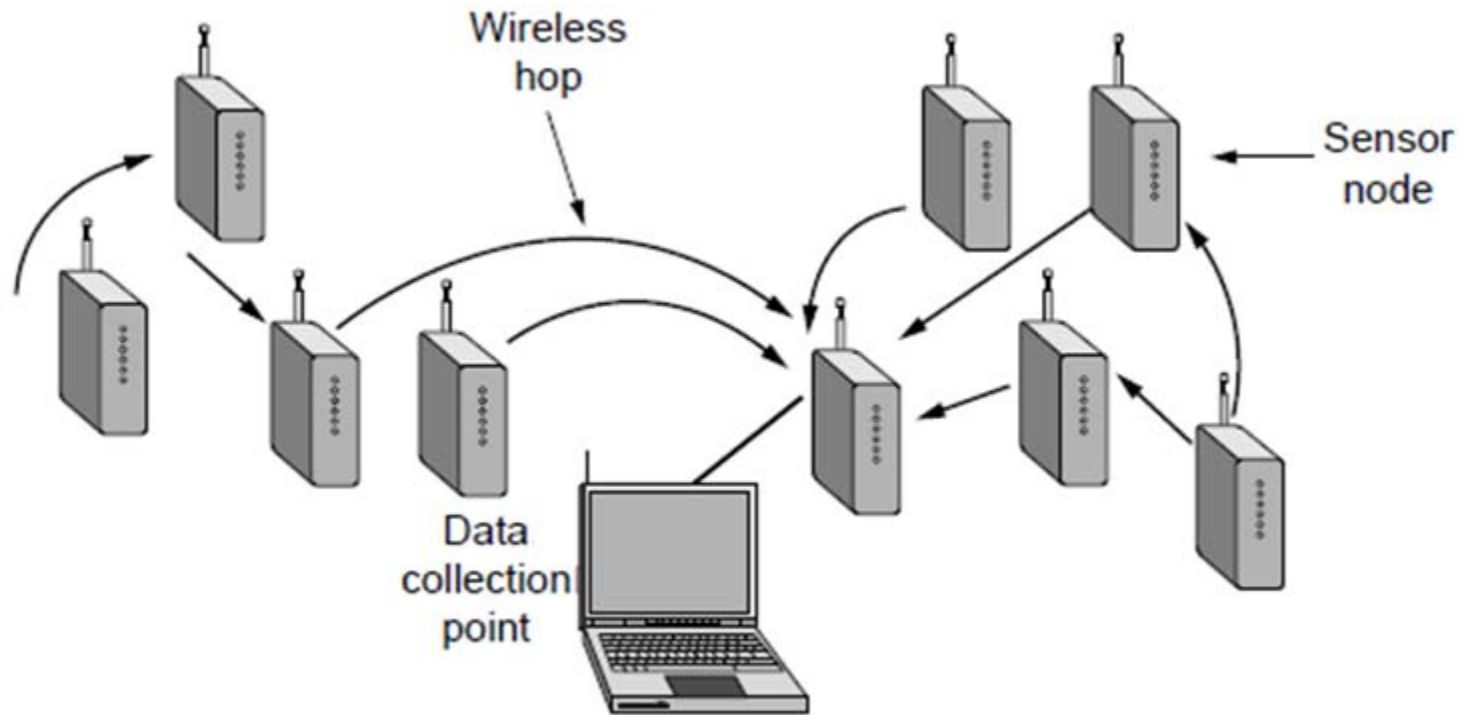

Multihop topology of a sensor network

# Network Standardization

- Who's Who in telecommunications
- Who's Who in international standards
- Who's Who in internet standards

# Who's Who in International Standards (1)

Number	Topic
802.1	Overview and architecture of LANs
802.2 ↓	Logical link control
802.3 *	Ethernet
802.4 ↓	Token bus (was briefly used in manufacturing plants)
802.5	Token ring (IBM's entry into the LAN world)
802.6 ↓	Dual queue dual bus (early metropolitan area network)
802.7 ↓	Technical advisory group on broadband technologies
802.8 †	Technical advisory group on fiber optic technologies
802.9 ↓	Isochronous LANs (for real-time applications)
802.10 ↓	Virtual LANs and security
802.11 *	Wireless LANs (WiFi)
802.12 ↓	Demand priority (Hewlett-Packard's AnyLAN)

The 802 working groups. The important ones are marked with \*. The ones marked with ↓ are hibernating. The one marked with † gave up and disbanded itself.

# Who's Who in International Standards (2)

802.13	Unlucky number; nobody wanted it
802.14 ↓	Cable modems (defunct: an industry consortium got there first)
802.15 *	Personal area networks (Bluetooth, Zigbee)
802.16 *	Broadband wireless (WiMAX)
802.17	Resilient packet ring
802.18	Technical advisory group on radio regulatory issues
802.19	Technical advisory group on coexistence of all these standards
802.20	Mobile broadband wireless (similar to 802.16e)
802.21	Media independent handoff (for roaming over technologies)
802.22	Wireless regional area network

The 802 working groups. The important ones are marked with \*. The ones marked with ↓ are hibernating. The one marked with † gave up and disbanded itself.

# Metric Units (1)

<b>Exp.</b>	<b>Explicit</b>	<b>Prefix</b>
$10^{-3}$	0.001	milli
$10^{-6}$	0.000001	micro
$10^{-9}$	0.000000001	nano
$10^{-12}$	0.0000000000001	pico
$10^{-15}$	0.0000000000000001	femto
$10^{-18}$	0.0000000000000000001	atto
$10^{-21}$	0.00000000000000000000001	zepto
$10^{-24}$	0.0000000000000000000000001	yocto

The principal metric prefixes

# Metric Units (2)

<b>Exp.</b>	<b>Explicit</b>	<b>Prefix</b>
$10^3$	1,000	Kilo
$10^6$	1,000,000	Mega
$10^9$	1,000,000,000	Giga
$10^{12}$	1,000,000,000,000	Tera
$10^{15}$	1,000,000,000,000,000	Peta
$10^{18}$	1,000,000,000,000,000,000	Exa
$10^{21}$	1,000,000,000,000,000,000,000	Zetta
$10^{24}$	1,000,000,000,000,000,000,000,000	Yotta

The principal metric prefixes

End

Chapter 1