

King Fahd University of Petroleum & Minerals Computer Engineering Dept

COE 202 – Fundamentals of Computer Engineering

Term 081

Dr. Ashraf S. Hasan Mahmoud

Rm 22-148-3

Ext. 1724

Email: ashraf@kfupm.edu.sa

12/28/2008

Dr. Ashraf S. Hasan Mahmoud

1

Magnitude Comparator

- Definition: A magnitude comparator is a combinational circuit that compares two numbers A & B to determine whether:
 - A > B, or
 - A = B, or
 - A < B
- Inputs
 - First n-bit number A
 - Second n-bit number B
- Outputs
 - 3 output signals (GT, EQ, LT), where:
 1. GT = 1 IFF A > B
 2. EQ = 1 IFF A = B
 3. LT = 1 IFF A < B
- Note: Exactly One of these 3 outputs equals 1, while the other 2 outputs are 0`s

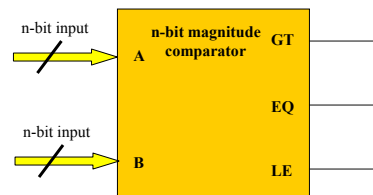

12/28/2008

Dr. Ashraf S. Hasan Mahmoud

2

Design Example 1: Magnitude Comparator

- **Problem:** Design a magnitude comparator that compares 2 4-bit numbers A and B and determines whether:
 - $A > B$, or
 - $A = B$, or
 - $A < B$

12/28/2008

Dr. Ashraf S. Hasan Mahmoud

3

4-bit Magnitude Comparator

- Inputs: 8-bits ($A \Rightarrow 4\text{-bits}$, $B \Rightarrow 4\text{-bits}$)
 - A and B are two 4-bit numbers
- Let $A = A_3A_2A_1A_0$, and
- Let $B = B_3B_2B_1B_0$
- Inputs have 2^8 (256) possible combinations (size of truth table and K-map?)
- Not easy to design using conventional techniques

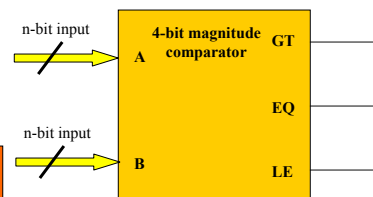

The circuit possesses certain amount of regularity
 \Rightarrow can be designed algorithmically.

12/28/2008

Dr. Ashraf S. Hasan Mahmoud

4

4-bit Magnitude Comparator: Design of the EQ Output

- When two binary numbers are EQUAL?
- Define $X_i = A_i \text{ XNOR } B_i = A_i B_i + A_i' B_i'$
 - $\rightarrow X_i = 1$ IFF $A_i = B_i \forall i = 0, 1, 2$ and 3
 - $\rightarrow X_i = 0$ IFF $A_i \neq B_i$
- Therefore the condition for $A = B$ or $EQ=1$ IFF
 1. $A_3=B_3 \rightarrow (X_3 = 1)$, and
 2. $A_2=B_2 \rightarrow (X_2 = 1)$, and
 3. $A_1=B_1 \rightarrow (X_1 = 1)$, and
 4. $A_0=B_0 \rightarrow (X_0 = 1)$.
- Thus, $EQ=1$ IFF $X_3 X_2 X_1 X_0 = 1$. In other words,
 $EQ = X_3 X_2 X_1 X_0$

12/28/2008

Dr. Ashraf S. Hasan Mahmoud

5

4-bit Magnitude Comparator: Design of the GT Output

- When can you say that A is GREATER THAN B?
- **Case 1: If $A_3 > B_3$** , then $A > B$ ($GT=1$)
 - Irrespective of the relative values of the other bits of A & B.
 - Example, $A = 1000$ and $B = 0111$ where $A > B$.
- How to represent $A_3 > B_3$ using logic?
 - This can be stated as $GT=1$ if $A_3 B_3' = 1$
- **Case 2: If $A_3 = B_3$ (i.e. $X_3 = 1$)**, we compare the next significant pair of bits (A_2 & B_2)
- If $A_2 > B_2$ then $A > B$ ($GT=1$) irrespective of the relative values of the other bits of A & B.
 - Example, $A = 0100$ and $B = 0011$ where $A > B$.
- How to represent this case using logic?
 - This can be stated as $GT=1$ if $X_3 A_2 B_2' = 1$

12/28/2008

Dr. Ashraf S. Hasan Mahmoud

6

4-bit Magnitude Comparator: Design of the GT Output – cont'd

- **Case 3: If $A_3 = B_3$ ($X_3 = 1$) and $A_2 = B_2$ ($X_2 = 1$),** we compare the next significant pair of bits (A_1 & B_1).
 - If $A_1 > B_1$, then $A > B$ ($GT=1$)
 - Irrespective of the relative values of the other bits of A & B .
 - Example, $A = 0010$ and $B = 0001$ where $A > B$
 - This can be stated as $GT=1$ if $X_3 X_2 A_1 B_1'$
- **Case 4: If $A_3 = B_3$ ($X_3 = 1$) and $A_2 = B_2$ ($X_2 = 1$) and $A_1 = B_1$ ($X_1 = 1$),** we compare the next pair of bits (A_0 & B_0).
 - If $A_0 > B_0$ then $A > B$ ($GT=1$).
 - This can be stated as $GT=1$ if $X_3 X_2 X_1 A_0 B_0' = 1$

12/28/2008

Dr. Ashraf S. Hasan Mahmoud

7

4-bit Magnitude Comparator: Design of the GT Output – cont'd

- To summarize, $GT = 1$ ($A > B$) IFF:
 - $A_3 B_3' = 1$, OR
 - $X_3 A_2 B_2' = 1$, OR
 - $X_3 X_2 A_1 B_1' = 1$, OR
 - $X_3 X_2 X_1 A_0 B_0' = 1$, OR
- In other words,
$$GT = A_3 B_3' + X_3 A_2 B_2' + X_3 X_2 A_1 B_1' + X_3 X_2 X_1 A_0 B_0'$$

12/28/2008

Dr. Ashraf S. Hasan Mahmoud

8

4-bit Magnitude Comparator: Design of the LE Output – cont'd

- In the same manner as for the GT output, we can derive the expression of the LT ($A < B$) output

$$LT = B_3 A_3' + X_3 B_2 A_2' + X_3 X_2 B_1 A_1' + X_3 X_2 X_1 B_0 A_0'$$

12/28/2008

Dr. Ashraf S. Hasan Mahmoud

9

4-bit Magnitude Comparator: Circuit

- Three functions:

$$EQ = X_3 X_2 X_1 X_0$$

$$GT = A_3 B_3' + X_3 A_2 B_2' + X_3 X_2 A_1 B_1' + X_3 X_2 X_1 A_0 B_0'$$

$$LT = B_3 A_3' + X_3 B_2 A_2' + X_3 X_2 B_1 A_1' + X_3 X_2 X_1 B_0 A_0'$$

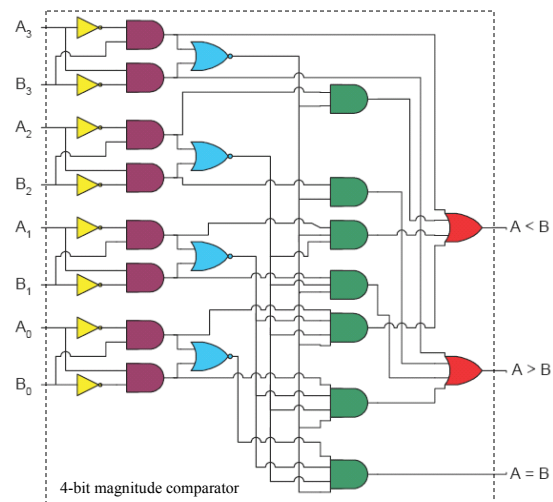

12/28/2008

Dr. Ashraf S. Hasan Mahmoud

10

4-bit Magnitude Comparator: Modification

- Do you need all three outputs?
- Two outputs can tell about the third one
 - Example: when A is NOT GREATER THAN B, and A is NOT LESS THAN B THEN A is EQUAL TO B
- Therefore, we can save some logic gates:

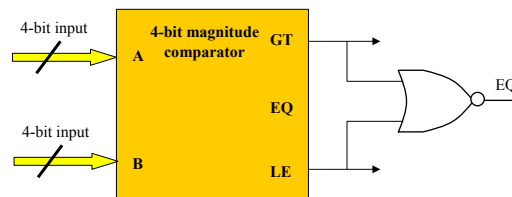

12/28/2008

Dr. Ashraf S. Hasan Mahmoud

11

Design Example 2:

- **Problem:** Given two 4-bit unsigned numbers A and B, design a circuit which outputs the larger of the 2 numbers.

Hint: use a quad 2-1 Mux.

- **Solution:**
- We need
 - 4-bit magnitude comparator to determine which number is greater
 - Quad 2-to-1 mux to select between A and B
 - The selection signal for the mux must be generated by the comparator
 - See circuit

Note the relation between the selection signal and order of inputs 0 and 1 for the mux

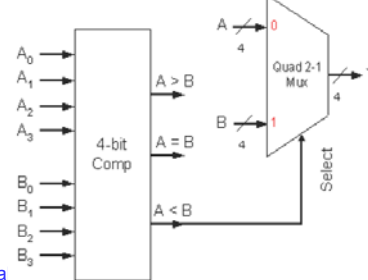

12/28/2008

Dr. Ashraf S. Hasan Ma

Design Example 3: Excess-3 Code Converter

- **Problem:** Designing an Excess-3 code converter using a Decoder and an Encoder
- **Solution:**
- Truth Table is as shown
- The outputs 0000, 0001, 0010, 1101, 1110, and 1111 are never generated (Why?)

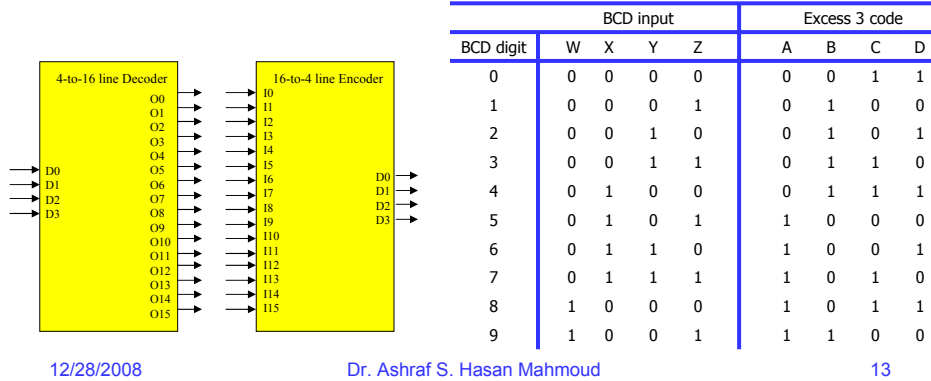

Example 3: cont'd

- **Solution:**
- What do you think the output of the encoder will be?

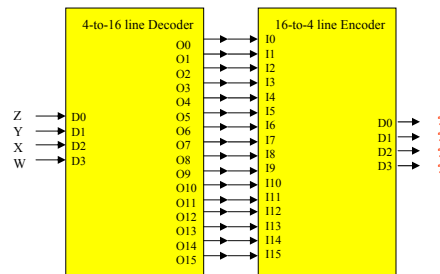

Output: D0 = Z, D1 = Y, D2 = X, D3 = W
So we get exact same code out!!

Example 3: cont'd

- **Solution:**
- We need to shift
- Example: suppose 0011 is sent as input. This will activate minterm 3 of the decoder. This output is connected to input 6 of encoder. Thus the encoder will generate the corresponding bit combination, which is 0110.

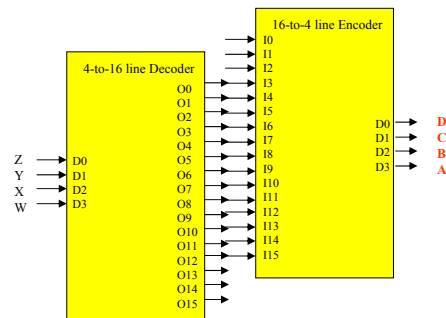

12/28/2008

Dr. Ashraf S. Hasan Mahmoud

15

Design Example 4:

- **Problem:** Design a circuit that adds three 4-bit numbers – utilize 4-bit adder blocks and half/full adder blocks
- **Solution:** refer to the last example in the adder slides

12/28/2008

Dr. Ashraf S. Hasan Mahmoud

16

Design Example 5:

- **Problem:** Design a 4-to-16 Decoder using **five** 2-to-4 Decoders with enable inputs. No extra logic is to be used.
- **Solution:**

12/28/2008

Dr. Ashraf S. Hasan Mahmoud

17

Design Example 5: cont'd

- **Solution:**
- How does a 2-to-4 decoder with Enable looklike?
- How does a 4-to-16 decoder looklike?

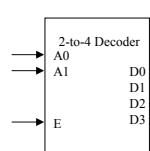

E	A1	A0	D0	D1	D2	D3
1	0	0	1	0	0	0
1	0	1	0	1	0	0
1	1	0	0	0	1	0
1	1	1	0	0	0	1
0	X	X	0	0	0	0

Truth Table

It is required to connect 4 boxes of 2-to-4 decoders to obtain the functionality of 4-to-16 decoder

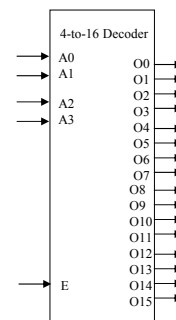

12/28/2008

Dr. Ashraf S. Hasan Mahmoud

18

Design Example 5: cont'd

- Solution:**

- A3A2, when decoded, can enable the require ONE of FOUR 2-to-4 decoders
- A1A0 always decoded into 4 outputs

	A ₃	A ₂	A ₁	A ₀	Output
A ₃ A ₂ = 00	0	0	0	0	O0
	0	0	0	1	O1
	0	0	1	0	O2
	0	0	1	1	O3
A ₃ A ₂ = 01	0	1	0	0	O4
	0	1	0	1	O5
	0	1	1	0	O6
	0	1	1	1	O7
A ₃ A ₂ = 10	1	0	0	0	O8
	1	0	0	1	O9
	1	0	1	0	O10
	1	0	1	1	O11
A ₃ A ₂ = 11	1	1	0	0	O12
	1	1	0	1	O13
	1	1	1	0	O14
	1	1	1	1	O15

12/28/2008

Dr. Ashraf S. Hasan Mahmoud

19

Design Example 5: cont'd

- Solution:**

	A ₃	A ₂	A ₁	A ₀	Output
A ₃ A ₂ = 00	0	0	0	0	O0
	0	0	0	1	O1
	0	0	1	0	O2
	0	0	1	1	O3
A ₃ A ₂ = 01	0	1	0	0	O4
	0	1	0	1	O5
	0	1	1	0	O6
	0	1	1	1	O7
A ₃ A ₂ = 10	1	0	0	0	O8
	1	0	0	1	O9
	1	0	1	0	O10
	1	0	1	1	O11
A ₃ A ₂ = 11	1	1	0	0	O12
	1	1	0	1	O13
	1	1	1	0	O14
	1	1	1	1	O15

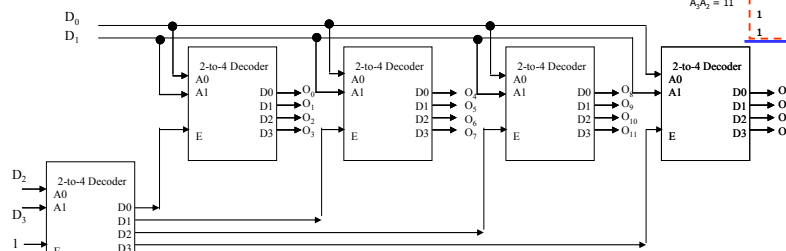

12/28/2008

Dr. Ashraf S. Hasan Mahmoud

20

Design Example 6:

- **Problem:** Designing a 16-bit adder using four 4-bit adders

- **Solution:**

Textbook Problems

4-4, 4-5, 4-6, ..., 4-25, 4-26
All are important problems!

Design Example 7: (similar to problem 4-21)

- **Problem:** A combinational circuit is defined by the following three Boolean functions:
 - $F1 = (X+Y)' + XYZ'$
 - $F2 = (X+Y)' + X'YZ$
 - $F3 = XYZ + (X+Y)'$

Design the circuit with a decoder and external OR gates

- **Solution:**

12/28/2008

Dr. Ashraf S. Hasan Mahmoud

23

Design Example 7: cont'd

- **Solution:**

- You should write each function in terms of its minterms:
 - $F1 = \sum m(0,1,6)$
 - $F2 = \sum m(0,1,3)$
 - $F3 = \sum m(0,1,7)$
- Use one OR gate for each function to sum the required minterms

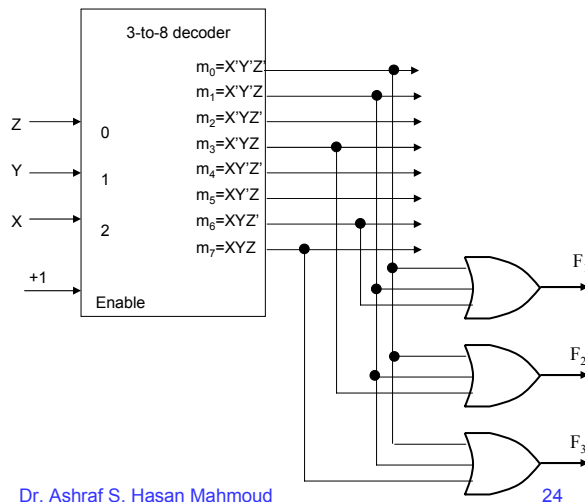

12/28/2008

Dr. Ashraf S. Hasan Mahmoud

24

Design Example 8: Problem 4-19 in textbook

- **Problem:** Construct a 15-to-1 line multiplexer with two 8-to-1 line multiplexers. Interconnect the two multiplexers and label the inputs such that any added logic required to have selection codes 0000 through 1110 is minimized.
- **Solution:**

12/28/2008

Dr. Ashraf S. Hasan Mahmoud

25

Design Example 8: cont'd

- **Solution:**

A ₃	A ₂	A ₁	A ₀	Output
0	0	0	0	D0
0	0	0	1	D1
0	0	1	0	D2
0	0	1	1	D3
0	1	0	0	D4
0	1	0	1	D5
0	1	1	0	D6
0	1	1	1	D7
1	0	0	0	D8
1	0	0	1	D9
1	0	1	0	D10
1	0	1	1	D11
1	1	0	0	D12
1	1	0	1	D13
1	1	1	0	D14
1	1	1	1	D15

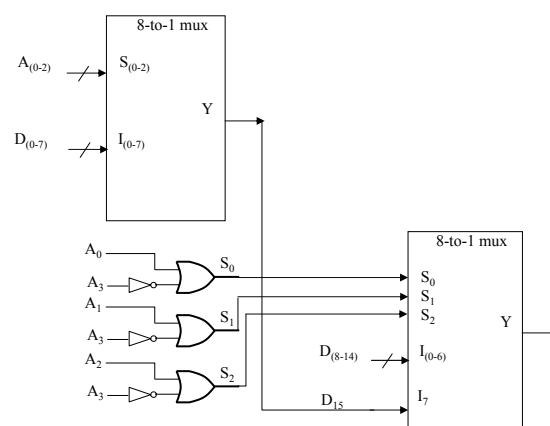

12/28/2008

Dr. Ashraf S. Hasan Mahmoud

26