

Name: KEY

Id#

COE 205, Term 023

Computer Organization & Assembly Programming
Quiz# 7

Date: Wednesday, August 20

Q1. Consider the one-bus CPU organization shown below. Assume that the CPU has only three general registers, namely R0, R1, and R2. Furthermore, assume that the ALU can perform any of the following four functions based on the control signals $f1$, $f2$, $f3$, and $f4$, as shown below:

$$f1: C=A+B;$$

$$f2: C=A-B;$$

$$f3: C=A+1;$$

$$f4: C=A-1;$$

- (i) Write the minimum number of control steps required to **fetch** an instruction using this CPU. Assume that the memory is asynchronous and that each instruction occupies one memory location.
- (ii) Write the minimum number of control steps required to **execute** each of the following instructions:
 - (a) JE label ; if the zero flag is 1, then jump to label. Assume that Label is a short address.
 - (b) SUB J, 5 ; subtract the constant 5 from the content of memory variable J.
 - (c) XCHG R1, R2 ; exchange the content of register R1 and register R2;
 - (d) LOOP label ; decrement the content of R0 and then branch conditionally to label if the zero flag equals to 0. The branch address is specified using relative addressing mode.
- (iii) Assuming that the instruction set of the CPU consists of only the four instructions mentioned above, determine the logic needed in the encoder of a hardwired control unit for the signal PC_{in} .

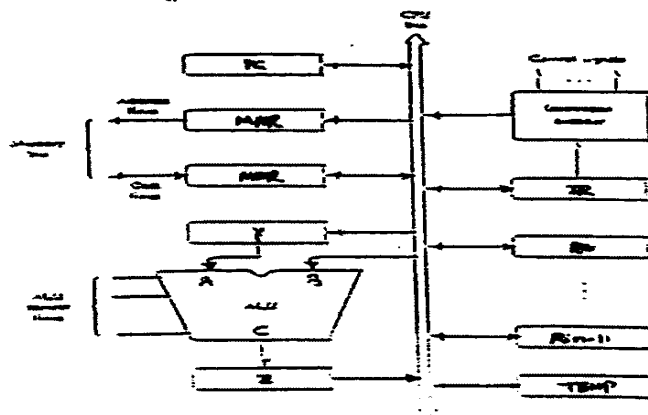

(i) T₁ PCout, MARin, Read, Yin
 T₂ f₃, Zin
 T₃ Zout, PCin, WMFC
 T₄ MDRout, IRin

(ii) a. JE label

T₅ PCout, Yin, if (ZF=0) END
 T₆ IRout, f₁, Zin
 T₇ Zout, PCin, END

b. SUB J, 5

T₅ IRout, MARin, Read, WMFC
 T₆ MDRout, Yin
 T₇ IRout, f₂, Zin
 T₈ Zout, MDRin, write, WMFC
 T₉ END

c. XCHG R1, R2

T₅ R1out, Tempin
 T₆ R2out, R1in
 T₇ Tempout, R2in, END

d. Loop label

T₅ R0out, Yin
 T₆ f₄, Zin
 T₇ Zout, R0in, if (ZF=1) end
 T₈ PCout, Yin
 T₉ IRout, f₁, Zin
 T₁₀ Zout, PCin, end

(iii) PCin = T₃ + JE · T₇ + Loop · T₁₀

Q2. It is required to design a data path to execute the following two types of instructions: *MOV Rdst, Rsrc* and *ADD Rdst, Rsrc*, where *Rsrc* and *Rdst* can be either R0, R1, R2, or R3. Show the data-path design and indicate all the signals needed to control it. Note that you only need to show the interconnection of the registers with the adder i.e., there is no need to show the PC, IR, MAR and MDR registers.

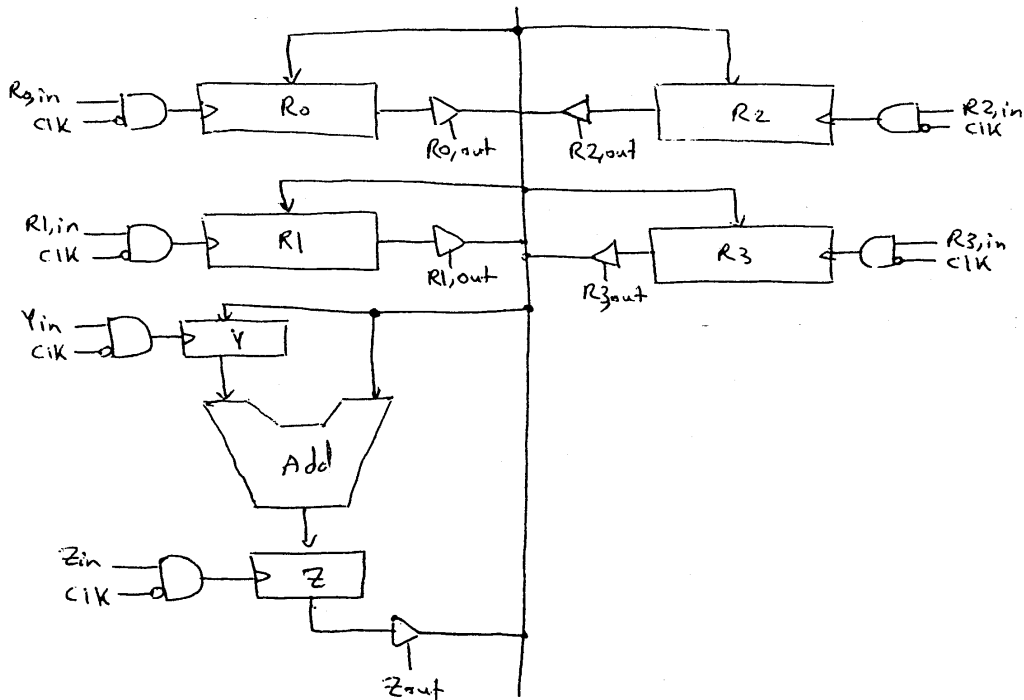

Note that the signals $R_{0,out}$, $R_{1,out}$, $R_{2,out}$, and $R_{3,out}$ are derived from the signals $R_{src,out}$, $R_{dst,out}$ and the content of IR. Similarly, the signals $R_{0,in}$, $R_{1,in}$, $R_{2,in}$, and $R_{3,in}$ are derived from the signal $R_{dst,in}$ and the content of IR.