

Name:

Id#

COE 464, Term 042
Testing of Digital Circuits

Quiz# 3

Date: Tuesday, March 22, 2005

Q1. Consider the circuit given below and assume that you have all the single stuck-at faults in the circuit, without fault collapsing, to be fault simulated:

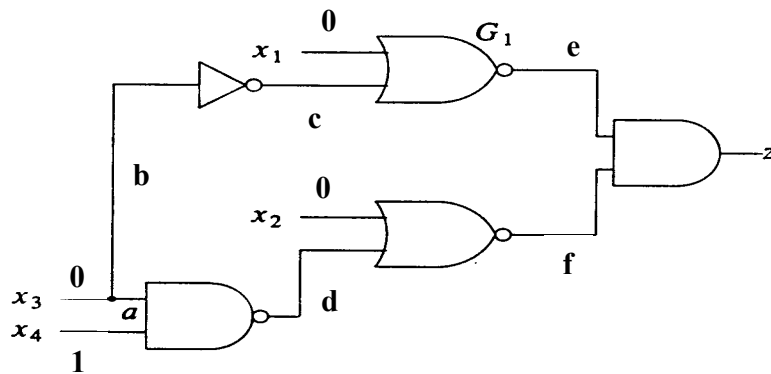

- i. Using **Deductive fault simulation** technique, determine the set of faults detected by the test vector $x_1x_2x_3x_4 = \{0001\}$.