

PRINCETON APPLIED RESEARCH

Electrochemical Instruments Division

APPLICATION NOTE CORR-4

ELECTROCHEMISTRY AND CORROSION OVERVIEW AND TECHNIQUES

Introduction

During the late 70's and early 80's, corrosion specialists began to discover that electrochemical (ECHEM) instruments could be valuable problem-solving tools. When manufacturers began to produce more compact and easy-to-use instruments, they became even more popular. The proliferation of books, papers, and articles on the advantages of ECHEM corrosion measurement makes it clear that ECHEM instrumentation is becoming a significant part of the corrosion specialist's repertoire.

Because of the rapid expansion in the literature, newcomers are learning that ECHEM instruments can help solve many of their most tedious and persistent corrosion problems. Techniques for applications such as rapid screening for materials selection, failure analysis, inhibitor evaluation, and even more specialized applications are becoming widely known and practiced. The National Association of Corrosion Engineers (NACE) and the American Society for Testing Materials (ASTM) have accepted several ECHEM corrosion methods as routine procedures, lending even greater credibility, and thus popularity, to ECHEM techniques.

Unfortunately, most of the literature either skips over the basic electrochemical theory (referring the reader to original literature) or presents the theory in complex mathematical terms (just as it's described in the original literature!). See, for example, the EG&G Princeton Applied Research Application Note Corr-1 and Bibliography.

This note presents to the non-electrochemist a brief and basic explanation of what ECHEM techniques can help you accomplish and how they work. It will become clear as you read this note that you can effectively apply these powerful tools to the corrosion problems in your lab without having to become an electrochemist.

Before going on to specific corrosion techniques, let's begin with an overview of electrochemistry and its

associated instrumentation as it pertains to corrosion measurements.

Electrochemistry — Why and How

Since corrosion is actually a process involving electrochemical oxidation and reduction reactions, it makes sense that electrochemical methods can be used to study and measure corroding systems.

More specifically, when a metal is immersed in a given solution, electrochemical reactions characteristic of the metal-solution interface occur at the surface of the metal, causing the metal to corrode. These reactions create an electrochemical potential, called the *corrosion potential* or the *open circuit potential* (measured in volts) at the metal-solution interface. Since the corrosion potential is determined by the specific chemistry of the system, it is a characteristic of the specific metal-solution system.

There is an important practical point to consider when measuring the corrosion potential. Simply stated, the corrosion potential (or E_{CORR}) of the metal-solution interface cannot be *directly* measured. Since all voltage measuring devices measure a potential energy *difference*, E_{CORR} can only be compared to the potential of a *known* reference system and can *only be indirectly* measured.

Figure 1 shows how you can easily measure E_{CORR} . With a reference electrode placed in the same solution as the metal, you can record E_{CORR} with an electrometer (a voltage measuring device). As long as you use the same type of reference electrode in each measurement, you should be able to consistently reproduce the E_{CORR} vs. E_{REF} measurement in any given metal-solution system.

Only a few types of reference electrodes have been used for corrosion work, and in recent years most corrosion specialists have been using a single type — the Saturated

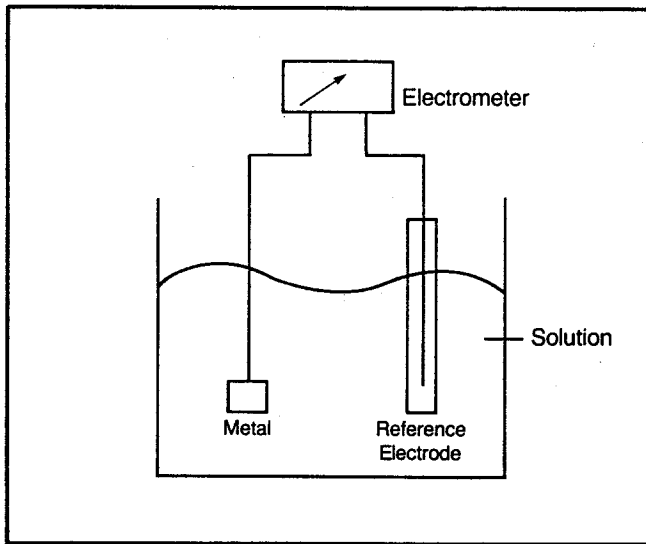

FIGURE 1. Measurement of E_{CORR} for a metal-solution system.

Calomel Electrode (SCE). Furthermore, if you measure E_{CORR} using a different type of reference electrode, you can easily convert the result of the measurement to an SCE-related value, since the potential differences between various types of reference electrodes are well documented.*

It will be helpful to understand the significance of E_{CORR} in terms of the electrochemical reactions that occur in a simple system. Iron corroding in air-free sulfuric acid provides a useful illustration. As shown in Figure 2, two separate reactions occur simultaneously.

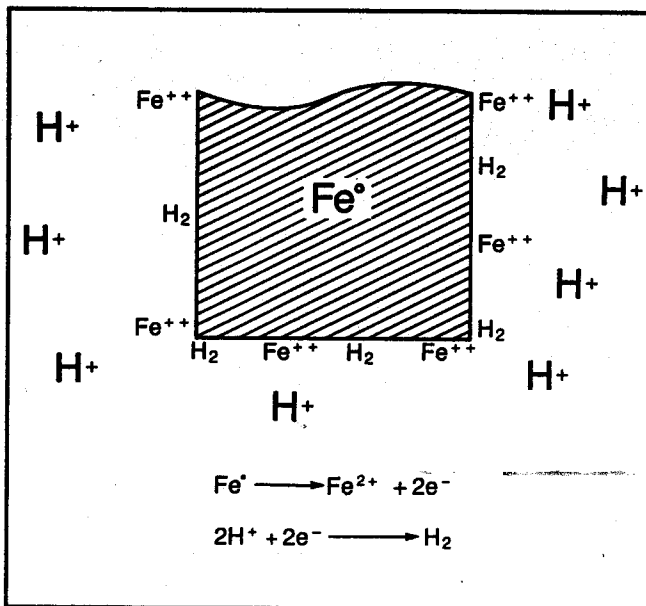

FIGURE 2. Chemistry of iron corroding in oxygen-free acid.

In one reaction, the iron oxidizes from the metallic state (Fe°) to the ionic species (Fe^{2+}). In this reaction, the +2 state of the oxidized form of iron indicates that two electrons are released from each atom of iron.

However, to maintain electronic neutrality, another species in this naturally occurring system must acquire these electrons. In an acidic solution, the positively charged hydrogen ions are readily available to fulfill this function. Thus, the hydrogen ions in solution gain the electrons released from the iron atoms to form neutral molecular hydrogen (H_2).

It is important to understand that at E_{CORR} the rate of the oxidation process is exactly equal to that of the reduction process. Therefore, at E_{CORR} the system is electronically neutral and is said to be "at equilibrium."

Potential and Current

Potential and current are the two fundamental variables in any ECHM experiment. No matter how complicated they may seem at first, all corrosion experiments boil down to the measurement and/or control of these variables.

The potential can be a product of the natural (that is, electrochemical) reaction between the metal and the solution, as it is when we attempt to measure E_{CORR} . Or the potential can be imposed on the metal by external ECHM instrumentation. When an instrument expends electrical energy to shift a metal from its natural corrosion potential, it performs the work of stimulating either the oxidation or the reduction reactions. In this sense a potential can be viewed as a driving force which upsets the electron balance that normally exists at E_{CORR} . An electrode that is maintained at a potential other than E_{CORR} by an external instrument is said to be polarized.

As an oxidation or reduction reaction predominates at the metal surface, a flow of electrons (either to or from the metal) gives rise to a current. The current can be related to the rate of the electrochemical reaction, since it is a measure of the number of electrons that flow in a given period of time.

For corrosion work, polarity conventions exist which allow you to associate a measured potential or current with either an oxidation or a reduction reaction. The conventions are shown in Figure 3. Potentials positive of E_{CORR} will accelerate the oxidation reaction. The current resulting from the oxidation is called anodic current and is displayed with a positive polarity. Potentials negative of E_{CORR} will accelerate the reduction reaction. The current resulting from the reduction is called cathodic current and is displayed with a negative polarity.

*For example, if the E_{CORR} of a particular metal-solution system is SCE and the SCE is known to have a potential of 400 mV positive of reference electrode "X", then the same E_{CORR} would be expressed as -100 mV vs. X.

The reactions of iron in sulfuric acid provide good illustrations of the oxidation and reduction process. In this case, the open circuit potential, or E_{CORR} , is approximately -0.35 V vs. the SCE. If a potential of 0 V vs. the SCE is imposed on the system, an oxidation reaction will predominate and a positive (or anodic) current will be measured (note that 0 V is more positive than -0.35 V).

The following equation illustrates the oxidation process that occurs when a positive potential is applied to an iron specimen.

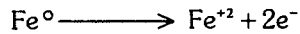

The iron specimen (Fe^0) reacts in the sulfuric acid solution to yield an iron ion (Fe^{+2}) and two free electrons ($2e^-$). When a positive potential is applied to the specimen, this oxidation reaction is the one that predominates.

If a potential of -0.70 V vs. the SCE is imposed on the system, a reduction reaction will predominate and a negative (or cathodic) current will be measured (note that -0.70 V is less positive than -0.35 V).

The following equation illustrates the reduction process that occurs when a negative potential is applied to an iron specimen.



The hydrogen ions ($2H^+$) present in acidic solutions react with the free electrons ($2e^-$) to yield hydrogen gas. When a negative potential is applied to the specimen, this reduction reaction is the one that predominates.

As implied in the above discussion of potential and current, the reduction current, or i_{RED} , in any reaction is associated with the electron flow due to the reduction process. Similarly, the oxidation current, or i_{OX} , is associated with the electron flow due to the oxidation process. Another way of viewing electronic neutrality at E_{CORR} is that at the corrosion potential, $i_{RED} = i_{OX}$. Since these currents flow in opposite directions:

$$i_{TOTAL} = i_{RED} + i_{OX} = 0$$

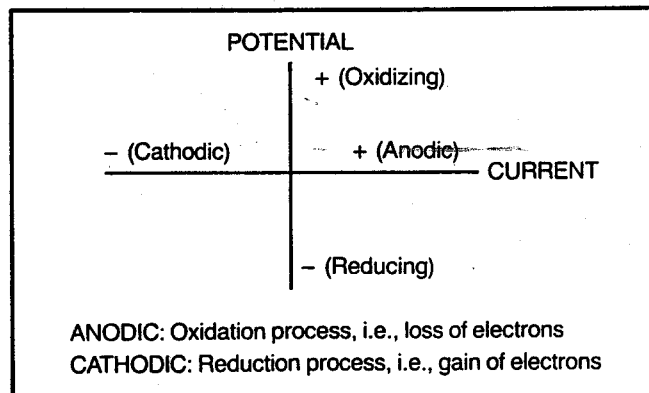

FIGURE 3. Corrosion conventions for plotting potential vs. current curves.

If you attempt to measure the current flowing at the metal specimen, you will read a value of zero since only i_{TOTAL} can be directly measured by the instrumentation.

This is an unfortunate limitation, since if i_{OX} or i_{RED} could be directly measured at E_{CORR} , calculating the naturally occurring rate of oxidation (i.e., the corrosion rate) would be a simple operation.

As will be discussed, it is possible to impose potentials other than E_{CORR} at the metal-solution interface by intervening with the proper instrumentation (this is called *polarization*). Polarization stimulates the oxidation or reduction reactions at the test specimen. By polarizing in a systematic manner and measuring the resulting current, you can determine the value of i_{OX} or i_{RED} at E_{CORR} . This current is commonly called the *corrosion current* or i_{CORR} , and is directly related to the corrosion rate. It is also possible to accelerate passivation, pitting, or other slow processes by applying a potential to the specimen.

The Test Cell and Instrumentation

Figure 4 represents the test cell used in a typical electrochemical corrosion measurement. The test cell includes the metal specimen (commonly called the *working electrode*) and the solution in which the specimen is to be tested. The *reference electrode* contacts the solution via the *bridge tube*, a compartment filled with test solution which provides optimum positioning of the reference electrode. Finally, a *counter electrode* (sometimes two) is used to supply the current flowing at the working electrode during the test.

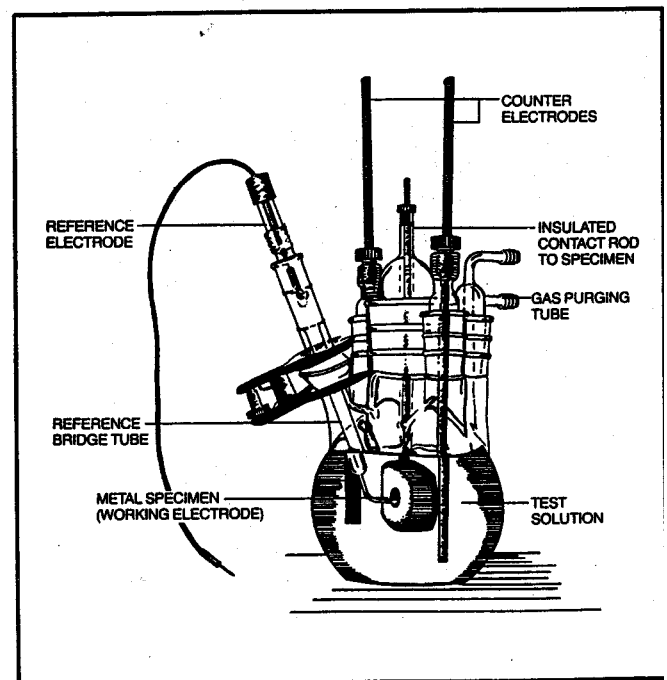

FIGURE 4. A typical electrochemical corrosion test cell.

Several types of corrosion cells are commercially available, although some applications may require a special cell design. A corrosion cell may be as simple as a beaker or as complex as an autoclave.

The heart of an ECHM corrosion measurement system is the *potentiostat*. As shown in Figure 5, a potentiostat can be viewed as a "black box" which performs two main functions:

- (1) It controls the potential difference between the reference electrode and the working electrode, i.e., it imposes an *applied potential* (E_{APP}).
- (2) It measures the current flow between the working electrode and the counter electrode. This is the i_{TOTAL} measurement referred to in the previous section.

In addition, the potentiostat makes the values of E_{APP} and i_{TOTAL} available to a recorder or a computer for subsequent analysis. The modern potentiostat is also capable of measuring E_{CORR} .

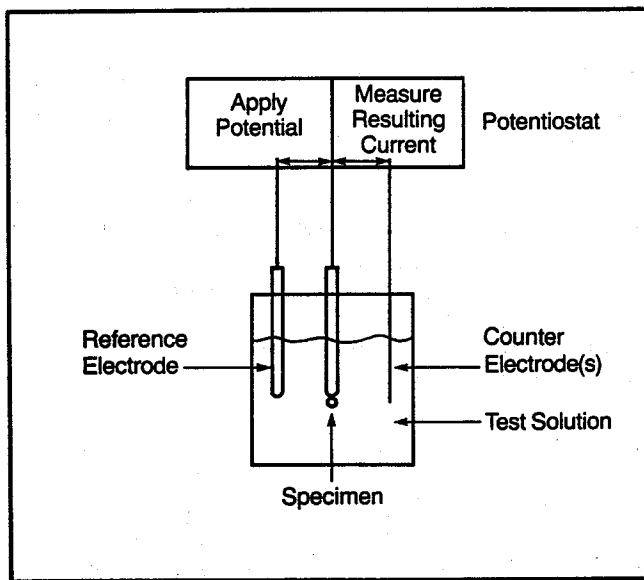

FIGURE 5. Potentiostat operation.

Scanning the Applied Potential and Displaying the Data

In many corrosion testing applications, it is advantageous to produce a graph of the measured current vs. the applied potential. The modern potentiostat gives you an easy way to do this. You can program the potentiostat to apply a continuously varying potential to the working electrode, beginning from an *initial potential* and ending at a *final potential*. This gradual change in applied potential is called a *scan*; and the rate at which the potential changes is called the *scan rate*.

Figure 6 shows a typical scanning waveform and illustrates how the applied potential changes linearly with time. Typical scan rates range from 0.1 mV/sec to 10 mV/sec.

The potentiostat can be programmed to perform a scan in either of two ways. It can accept a *scanning waveform* from a *wave-form generator* (either external or built-in), or, if the potentiostat has

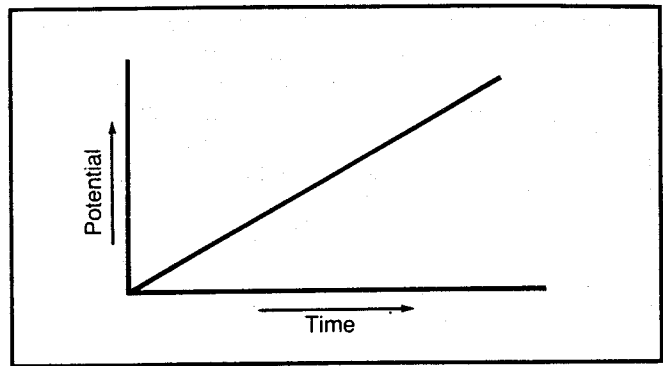

FIGURE 6. A typical scanning waveform.

been designed for computer-assisted operation, it can accept a computer-generated waveform.

As the applied potential is varied, the current is continually measured. The most common way to display the data is to plot the applied potential vs. current (or sometimes the log of the current).

Figure 7 shows a simple, hypothetical potential-current curve. Note that from this type of plot you can determine the current at any given value of applied potential (or vice versa).

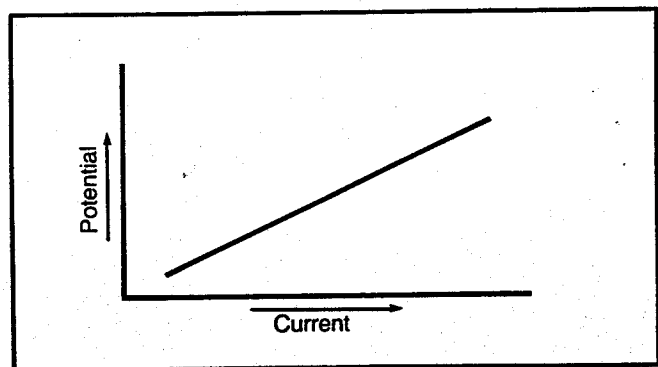

FIGURE 7. A hypothetical potential vs. current plot.

The data plot can be displayed on an appropriate recorder or on the associated computer screen or printer. In any case, once a test is initiated, the operator is free for other tasks since scanning and data acquisition are automatic.

Once a data plot is obtained, you can use the data for qualitative interpretation or for calculation. Depending on the type of scanning waveform and data plot used, you can, for example, observe passivation phenomena, determine a specimen's pitting tendencies, or calculate the corrosion rate.

It is at the data interpretation stage of the test where a computer-assisted measurement system offers an important advantage. When the data is plotted on a recorder, you must perform *manual* measurements of the plot and certain *manual* calculations to obtain the end result. Of course, once the data is collected by a computer, it is in

the ideal place for *automatic* reduction and calculation. Figure 8 shows two block diagrams illustrating the semi-automated vs. computer-assisted approaches to ECHM testing.

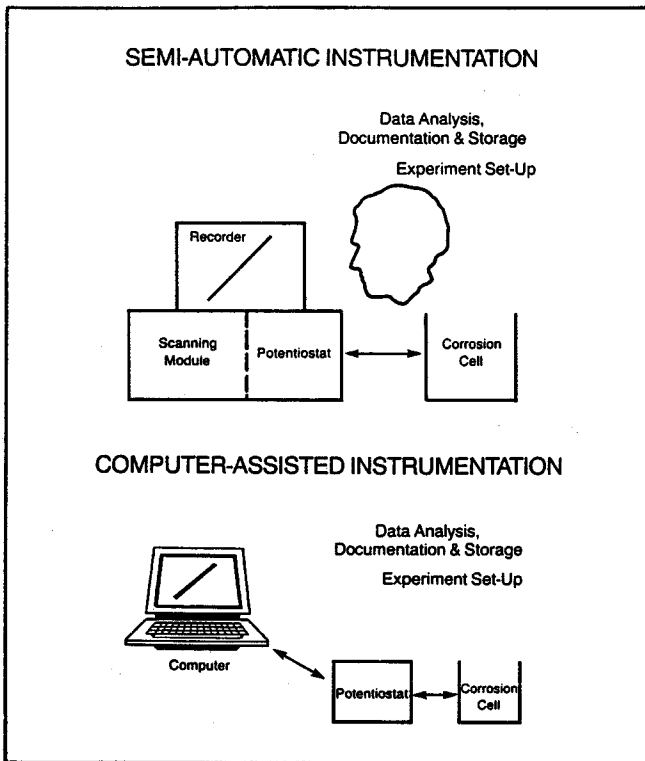

FIGURE 8. Block diagrams of semi-automated and computer-assisted corrosion measurement systems.

The Uncompensated Resistance

It is inherent in the design of the modern electrochemical cell that a resistance exists between the working and reference electrodes. If left uncorrected, this *uncompensated resistance* (or R_U) can cause an error in the applied potential.

Electrochemical cells are designed to allow current to flow between the working and counter electrodes (the electrodes across which the measurements are taken). A third electrode, called the *reference electrode*, is inserted near the working electrode to sense the applied potential. The sensed potential is then fed back to the associated potentiostat to control its output.

However, no matter how closely the reference electrode is positioned to the working electrode, there will always be *some* solution resistance between them. Since a large current often flows through the solution, there can be a significant voltage (or iR) drop between the working and reference electrodes.

More specifically, the purpose of the reference electrode is to measure the *potential across the specimen surface*, since it is this potential that

stimulates the desired electrochemical reaction. However, R_U prevents the reference electrode from sensing the true potential at the specimen. Instead, it will sense the applied voltage *minus* the iR drop ($E_{APP} - iR$ drop) and transmit a distorted reading of the *effective* potential to the controlling potentiostat. Thus, an error will be introduced into the measurement.

The applied potential error, or E_{ERR} , can be calculated by multiplying the current by the uncompensated resistance at the time of the measurement. (This conforms with Ohm's Law, expressed in standard units: *amps* \times *ohms* = *volts*.) This error is often called the *iR error* or *iR drop*.

The three techniques used to compensate for iR error are explained in the following paragraphs.

After the Scan Correction

If you measure R_U at the beginning of the experiment and then perform the scan, the potential of each data point on the plot can be adjusted using the calculated E_{ERR} values. This approach has two disadvantages. First, R_U may change during the scan, causing errors in the calculation of E_{ERR} . And secondly, the correction is made *after* the measurement, and the applied potential may be altered during the scan by the iR drop. Thus, the scan may not truly go to the desired E_{FINAL} , and the true scan rate may vary during the test.

Positive Feedback

In this technique, before the scan, you make a rather tedious "feedback" adjustment from the controlling potentiostat. Once the feedback level is set, the potentiostat will automatically correct its output (the applied potential) under control of the current it is measuring. This on-the-fly correction is an improvement over the previous method, since the E_{FINAL} value and the scan rate are corrected. However, this correction may not completely eliminate the error, since the feedback level is based on the initial value of the uncompensated resistance, which can change during the test.

Current-Interrupt

For corrosion measurements, this is the best solution to the R_U problem. The test is interrupted for a very short time (less than 0.0002 seconds!) at many points during the test. Each time this happens, a new value of E_{ERR} is determined and the value of E_{APP} is appropriately corrected. Because of the sophisticated electronics required to perform this task, very few commercial potentiostats offer Current-Interrupt iR Compensation.

Controlled Potential vs. Controlled Current Experiments

Most corrosion measurements involve a scan of the working electrode potential and a measurement of the resulting current. This is referred to as a *Potentiodynamic* scan, since the applied potential continuously changes. As will be discussed, it is sometimes useful to maintain a constant potential and plot the resulting current as a function of time. This kind of experiment is termed *Potentiostatic*.

It is also possible (and sometimes desirable) to control the *current* at the working electrode and measure the resulting potential. If the current is varied by the controlling instrument, the measurement is called a *Galvanodynamic* scan. If a constant current value is maintained and a potential vs. time curve is generated, the experiment is termed *Galvanostatic*.

Fittingly, the instrument required to achieve the controlled current measurement is called a *Galvanostat*. Most commercial potentiostats can also function as galvanostats.

Popular Corrosion Measurement Techniques

Tafel Plot

Purpose

This technique is used to measure the corrosion current (i_{CORR}) so that the corrosion rate can be calculated. A Tafel Plot can yield i_{CORR} directly or it can yield the Tafel Constants (β_A and β_C). The Tafel Constants can then be used with the R_p value to calculate i_{CORR} . (See Polarization Resistance)

Experimental Procedure

You can generate a Tafel Plot by beginning your scan at E_{CORR} and scanning to either -250 mV vs. E_{CORR} (for a cathodic Tafel Plot) or $+250$ mV vs. E_{CORR} (for an anodic Tafel Plot). It is possible to obtain both Tafel Plots in a single scan by beginning the scan -250 mV vs. E_{CORR} and scanning continuously to $+250$ mV vs. E_{CORR} . When you do this, there is a danger that the negative portion of the scan will alter the surface of the specimen and thus change its characteristics during the positive portion of the scan.

The scan rate is typically 0.1 mV/sec. The resulting curve is a plot of the applied potential vs. the logarithm of the measured current.

Data Interpretation

One way of determining i_{CORR} is to superimpose a straight line along the linear portion of the anodic

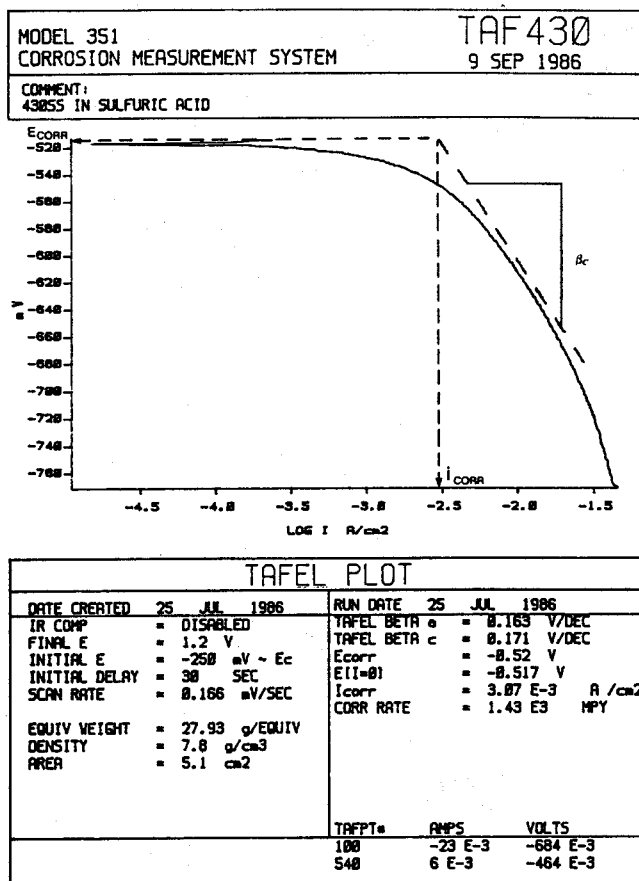

FIGURE 9. A typical cathodic Tafel Plot.

or cathodic curve and extrapolate it through E_{CORR} (see Figure 9). Under ideal conditions, the Tafel Plot will be linear over some range of potentials. For a cathodic Tafel Plot, this occurs between -50 mV and -250 mV vs. E_{CORR} . For an anodic plot, this occurs between $+50$ mV and $+250$ mV vs. E_{CORR} . If a "best fit" straight line is extrapolated through E_{CORR} , the point of intersection at E_{CORR} gives the i_{CORR} value.

For a single plot encompassing both the anodic and cathodic Tafel regions, the two straight line extrapolations should intersect at E_{CORR} (see Figure 10). If you do not observe this, then either the anodic or cathodic reaction is not consistent with the simple model upon which the technique is based. Other, more complex mechanisms are likely to be affecting one of the reactions. In this case, you can use the most linear Tafel Plot to determine i_{CORR} .

The slope of the straight line fit to the Tafel data is called a Tafel Constant (β). You determine an anodic Tafel Constant (β_A) from a fit of the anodic linear region and a cathodic Tafel Constant (β_C) from a fit of the cathodic linear region.

Once i_{CORR} has been determined, an equation can be used to calculate the corrosion rate. (See equation (3) in the Polarization Resistance Section.)

MODEL 351 CORROSION MEASUREMENT SYSTEM	TAF430 9 SEP 1986
COMMENT: 43055 IN SULFURIC ACID	

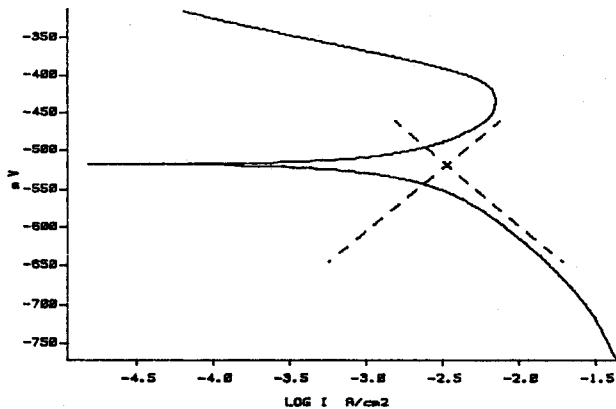

TAFEL PLOT				
DATE CREATED	25 JUL 1986	RUN DATE	25 JUL 1986	
IR COMP	= DISABLED	TAFEL BETA a	= 0.164 V/DEC	
FINAL E	= 1.2 V	TAFEL BETA c	= 0.169 V/DEC	
INITIAL E	= -250 mV ~ Ec	Ecorr	= -0.52 V	
INITIAL DELAY	= 30 SEC	E(I=0)	= -0.517 V	
SCAN RATE	= 0.166 mV/SEC	Icorr	= 3.34 E-3 A/cm2	
		CORR RATE	= 1.56 E3 MPY	
EQUIV WEIGHT	= 27.93 g/EQUIV			
DENSITY	= 7.8 g/cm3			
AREA	= 5.1 cm2			
		TAFFT#	AMPS	VOLTS
		180	-15 E-3	-644 E-3
		550	6 E-3	-459 E-3

FIGURE 10. Combined anodic and cathodic Tafel Plots.

You get the most accurate i_{CORR} measurement when you fulfill the following three conditions:

- (1) Make separate measurements to determine the β_A , β_C , and R_p values. (See Polarization Resistance.)
- (2) Use a new specimen and fresh solution for each measurement.
- (3) Use the equations from the Polarization Resistance experiment.

Polarization Resistance

Purpose

This technique is used to measure the Polarization Resistance (R_p). Polarization Resistance is defined as the resistance of the specimen to oxidation during the application of an external potential. The corrosion rate is directly related to the R_p and can be calculated from it.

Experimental Procedure

In a Polarization Resistance experiment, you obtain the data by scanning a range of ± 20 mV about E_{CORR} (the open circuit potential). A typical scan starts at -20 mV vs. E_{CORR} and ends at $+20$ mV vs. E_{CORR} . The scan rate is typically 0.1 mV/sec. The curve plots the applied potential vs. the measured current.

Data Interpretation

The most useful application of the R_p measurement is in calculating the corrosion rate. The following overview of some basic R_p theory shows how this is done.

R_p is determined by calculating the slope of the linear region of the plot (see Figure 11). Notice that the slope has units of resistance—hence the name Polarization Resistance.

MODEL 351 CORROSION MEASUREMENT SYSTEM	TAF430 28 OCT 1986
COMMENT: 43055 IN SULFURIC ACID	

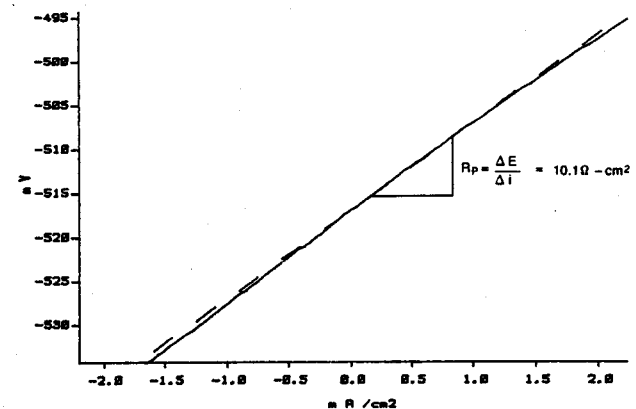

POLARIZATION RESISTANCE					
DATE CREATED	25 JUL 1986	RUN DATE	25 JUL 1986		
IR COMP	= DISABLED	TAFEL BETA a	= 0.168 V/DEC		
FINAL E	= 1.2 V	TAFEL BETA c	= 0.169 V/DEC		
INITIAL E	= -250 mV ~ Ec	Ecorr	= -0.52 V		
INITIAL DELAY	= 30 SEC	E(I=0)	= -0.517 V		
SCAN RATE	= 0.166 mV/SEC	Icorr	= 3.17 E-3 A/cm2		
		CORR RATE	= 1.47 E3 MPY		
EQUIV WEIGHT	= 27.93 g/EQUIV	RP calc.	= 10.10 Ohms		
DENSITY	= 7.8 g/cm3	ANODIC-BETA	= 0.168 V/DEC		
AREA	= 5.1 cm2	CATHODIC-BETA	= 0.168 V/DEC		
		Icorr calc.	= 3.62 E-3 A/cm2		
		CORR RATE calc	= 1.69 E3 MPY		
		TAFFT#	AMPS	VOLTS	
RPPT#	AMPS	VOLTS	180	-15 E-3	-644 E-3
477	2 E-3	-495 E-3	550	6 E-3	-459 E-3

FIGURE 11. A typical polarization resistance plot.

To calculate the corrosion rate, you must first determine the corrosion current (i_{CORR}). To determine the corrosion current from the Polarization Resistance plot, you also need the Tafel Constants (the slopes of the anodic and cathodic linear regions of the curve). You can measure the Tafel Constants from a previously run Tafel Plot or you can use known or estimated values. The following formula shows the relationship between the R_p value, the Tafel Constants, and the corrosion current.

$$\Delta E / \Delta i = R_p = \frac{\beta_A \beta_C}{2.3 (i_{CORR}) (\beta_A + \beta_C)} \quad (1)$$

where:

$\Delta E / \Delta i$ = the slope of the linear region = R_p

ΔE is expressed in volts (V)

Δi is expressed in microamperes (μA)

β_A = anodic Tafel Constant expressed in volts per decade of current.

β_C = cathodic Tafel Constant expressed in volts per decade of current.

2.3 = the natural log of ten

i_{CORR} = corrosion current (in μA)

[See PARC Application Note CORR-1 for the derivation of equation (1).]

From equation (1), you can derive the equation necessary to calculate the corrosion current.

$$i_{CORR} = \frac{\beta_A \beta_C}{2.3 (R_p) (\beta_A + \beta_C)} \quad (2)$$

Once i_{CORR} is determined, the corrosion rate (in milli-inches per year) can be calculated from the following equation:

$$\text{Corrosion Rate (MPY)} = \frac{0.13 i_{CORR} (\text{E.W.})}{A \cdot d} \quad (3)$$

where:

E.W. = equivalent weight (in g/eq.)

A = area (in cm²)

d = density (in g/cm³)

0.13 = metric and time conversion factor

In addition to yielding quantitative information such as corrosion current and corrosion rate, the R_p value can help you assess the *relative* ability of a material to resist corrosion. Since Polarization Resistance is inversely proportional to corrosion current, it is an easy matter to rank a number of materials according to their R_p values. Assuming all samples are of equal surface area, the materials with the highest R_p (and thus the lowest corrosion current) have the highest corrosion resistance (relative to the other materials).

There are two advantages of a Polarization Resistance plot over a Tafel Plot: first, the R_p measurement takes a much shorter time to make; secondly, the R_p technique exposes the specimen to smaller voltages, and thus does not significantly change the surface of the specimen.

Potentiodynamic Anodic Polarization

Purpose

This technique is used to determine the active/passive characteristics of a given metal-solution system.

Experimental Procedure

The potentiodynamic anodic polarization uses a potential scan typically starting at E_{CORR} (the open circuit potential) and scanning in a positive direction, usually to a potential positive enough to oxidize the test solution. The scan rate is typically 0.1 mV to 5 mV/sec. The most reliable data is generally acquired at slow scan rates. The graph plots the applied potential vs. the logarithm of the measured current.

Data Interpretation

Often potentiodynamic scans are run on a series of samples and relative differences are observed. The following paragraphs describe the most useful and instructive features of a potentiodynamic curve.

Overall shape: The overall shape of a curve is an indication of the corrosion behavior of the specimen in the test solution. You can quickly determine whether the specimen will passivate at all in the test solution. Moreover, you can easily determine if the passivation is spontaneous or if polarization is required to induce passivation. In addition, you can identify metal-solution systems capable of inducing a spontaneous change from passive to active behavior. (See PARC Application Note CORR-1 for a more detailed discussion.)

Critical E and i values: The potential and current values at critical points in the potentiodynamic curve reveal a great deal about the passivation tendencies of a specimen. Consider the peak-shaped active-to-passive transition of the curve in Figure 12. The low Critical Anodic Current at the peak of this curve indicates that the specimen passivates quickly. The closeness of the Primary Passive Potential to E_{CORR} suggests the tendency to passivate.

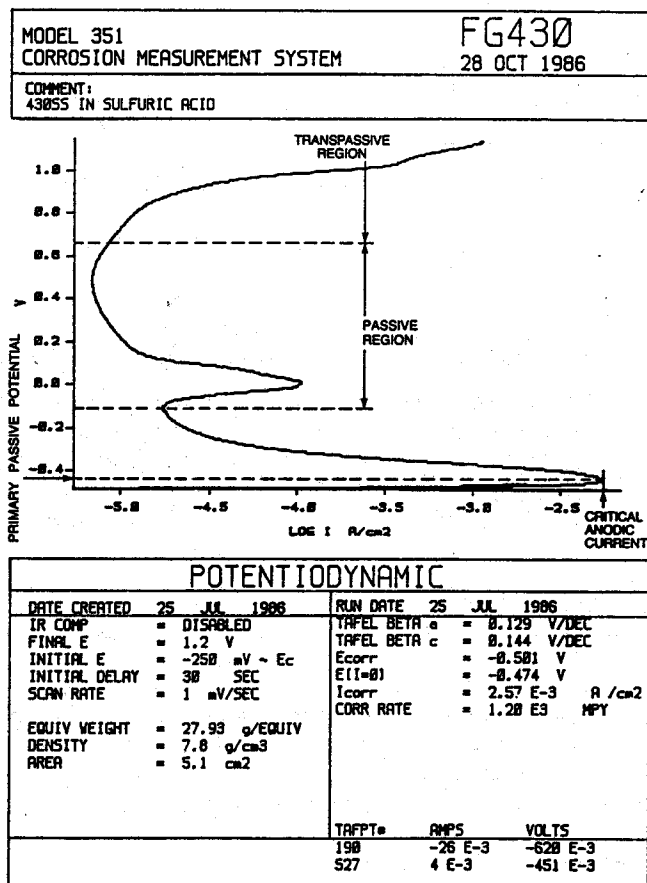

FIGURE 12. A typical potentiodynamic anodic polarization plot.

Passive region current and transpassive region potential: You can assess the degree of passivation and the stability of the passive film by observing the passive region current and the transpassive region potential. Lower currents in the passive region indicate a higher degree of

passivation. A transpassive region at a more positive potential indicates that the passive film has greater stability.

By modifying the initial potential, you can also use the data from a Potentiodynamic Plot to construct the cathodic Tafel Plot and the Polarization Resistance plot. You can then use the appropriate portions of the curve to make the same calculations made from Tafel Plot and Polarization Resistance plot experiments. This is illustrated in Figure 13.

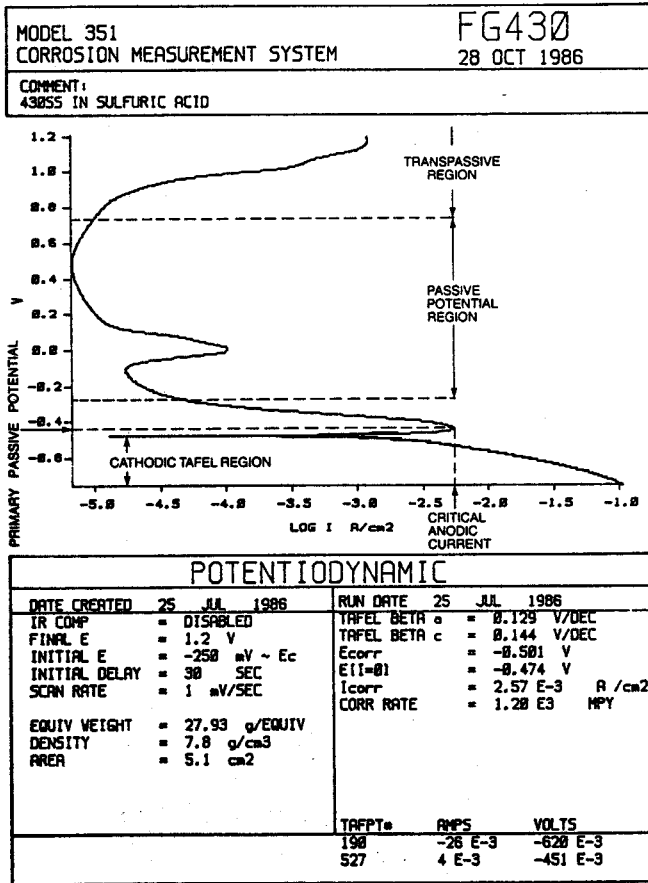

FIGURE 13. A typical potentiodynamic anodic polarization plot encompassing the cathodic Tafel region.

Cyclic Polarization

Purpose

This technique measures the pitting tendencies of a specimen in a given metal-solution system.

Experimental Procedure

In a pitting experiment, you apply a potential scan beginning at E_{CORR} (the open-circuit potential) and continuing in the positive (anodic) direction until a large increase in current occurs. When the scan reaches a user-programmed current density value, it reverses and begins scanning in a negative (cathodic) direction. The threshold current density is typically 1 mA/cm². The final potential of the scan should be negative with respect to E_{PRO} (see Data Interpretation) as determined by a preliminary scan. The resulting graph plots the applied potential vs. the logarithm of the measured current.

Data Interpretation

The potential at which the current sharply increases is defined as the pitting potential (E_{PIT}), as shown in Figure 14. When pitting occurs on the forward scan, the reverse scan will trace a hysteresis loop. The potential where the loop closes on the reverse scan is the protection (or repassivation) potential (E_{PRO}). If the loop does not close, E_{PRO} can be estimated by extrapolating the reverse scan to zero current.

If the pitting potential and the protection potential are the same, there will be little tendency to pit. If the protection potential is more positive (anodic) than the pitting potential, there will be no tendency to pit.

If the protection potential is more negative than the pitting potential, pitting could occur. Generally, the reverse scan is at a higher current level than the forward scan. The size of the pitting loop is a rough indication of pitting tendency; the larger the loop, the greater the tendency to pit.

Pitting experiments can be used to predict crevice corrosion as well as pitting corrosion. In general, the protection potential is the potential below which neither pitting nor crevice corrosion occur. The pitting potential is the potential above which both pitting and crevice corrosion will occur.

At potentials between the pitting and protection potentials, pitting or crevice corrosion will propagate but new pits will not appear. Thus, for reproducible pitting studies,

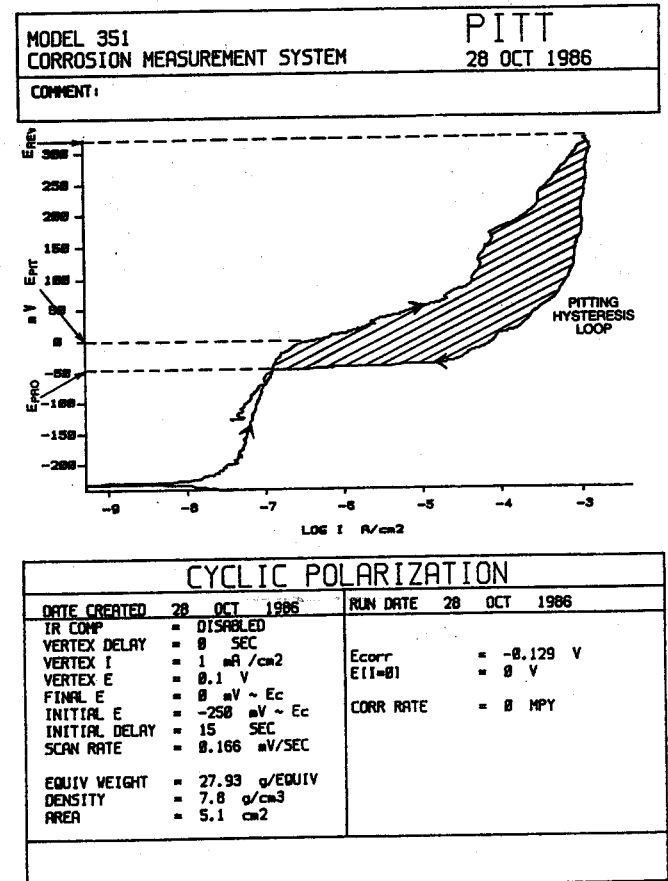

FIGURE 14. A typical cyclic polarization plot.

care must be taken to avoid using specimens with crevices or "shielded" areas.

On the other hand, an artificial crevice can be introduced if crevice corrosion information is desired. You should be aware that these measurements are qualitative in nature. No quantitative data related to a "pitting rate" is obtained.

As you can see, pitting experiments are not interpreted in a straightforward manner. Furthermore, the best procedure for measuring E_{PRO} and E_{PIT} has been a subject of debate. Computer-based EG&G PARC equipment is pre-programmed for the cyclic polarization experiment described above. Other techniques have been proposed to determine the protection potential. These include potential step galvanostaircase, activation of the sample followed by potential step, and pit propagation rate (PPR) experiments. Users interested in these techniques should refer to the literature for specifics.

Potentiostatic

Purpose

This technique applies a constant potential to the metal-solution interface and measures its electrochemical behavior as a function of time. Potentiostatic experiments can be used to determine diffusion coefficients of dissolved materials in a solution, to measure passivation or repassivation potentials and rates, and to evaluate anodic and cathodic protection techniques. Many other applications of the study of corrosion mechanisms have been reported in the literature.

MODEL 351 CORROSION MEASUREMENT SYSTEM	PSTAT 28 OCT 1986
COMMENT: 43855	

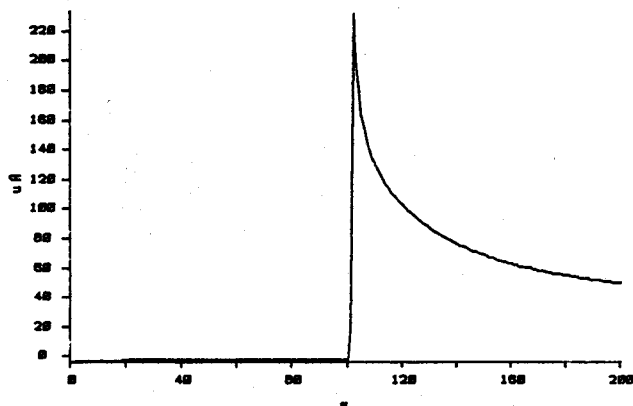

POTENTIOSTATIC	
DATE CREATED	28 OCT 1986
IR COMP	= DISABLED
FINAL E TIME	= 100 SEC
THRESHOLD I	= 1 mA
INIT E TIME	= 100 SEC
FINAL E	= 1 V
INITIAL E	= 0 mV ~ Ec
MEAS INTERVAL	= 1 SEC
EQUIV WEIGHT	= NONE ENTERED
DENSITY	= NONE ENTERED
AREA	= NONE ENTERED
RUN DATE	28 OCT 1986
Ecorr	= 8.27 V
E(I=0)	= 0 V

FIGURE 15. A typical potentiostatic plot illustrating passivation.

Experimental Procedure

A Potentiostatic scan begins at a programmed initial potential, and after a specified initial delay, steps to a programmed final potential. The final applied potential is maintained for a specified period of time. The current flowing as a result of the applied potential is plotted as a function of time.

Alternatively, you can program the instrument to step from the initial to the final potential when the measured current or current density crosses a predetermined *threshold* value. The data is plotted as current or current density vs. time.

Data Interpretation

Potentiostatic plots can be interpreted in a variety of ways, depending upon the specimen's physical characteristics and chemical behavior at the initial and final potentials.

The data in Figure 15 provides one example of this. If the potential steps from a protecting (cathodic) potential to a passivating (anodic) potential, the time required to obtain a steady low current value would be directly related to the rate of passivation under the given experimental conditions.

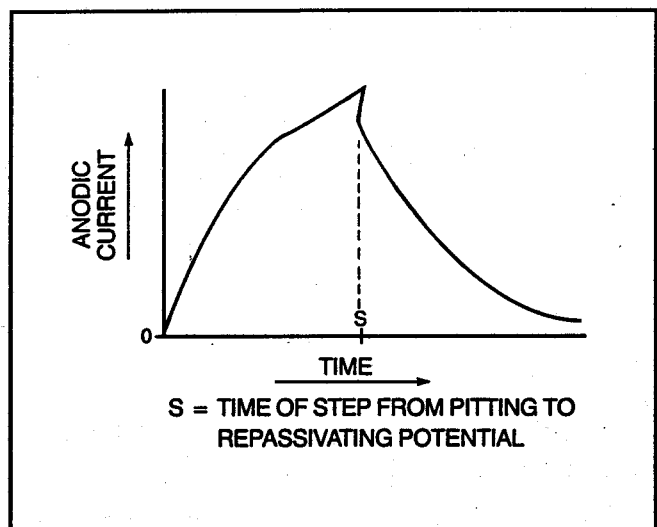

FIGURE 16. A hypothetical potentiostatic plot illustrating pit repassivation.

Figure 16 illustrates a different type of Potentiostatic experiment. The plot represents an experiment in which the initial potential induces pitting corrosion and the final potential causes repassivation of the initiated pits. A series of experiments in which the final potential is systematically varied would isolate those potentials that caused repassivation from those that didn't, and thus provide an accurate measurement of repassivation potential.

Galvanostatic

Purpose

This technique impresses a constant current upon the metal-solution interface and measures its electrochemical behavior as a function of time.

You can use Galvanostatic experiments to measure passivation rates, evaluate cathodic or anodic protection techniques, or gauge the thickness of passive films or electroplated layers. Many other applications of the Galvanostatic technique to the study of corrosion mechanisms have been reported in the literature.

Experimental Procedure

In the Galvanostatic technique, the impressed current or current density is typically stepped from an initial value to a final value after a specified initial delay. The final current is then maintained for a specified period of time. The specimen potential is continuously monitored during this process.

An alternative procedure is to step to the final current level when the specimen potential has reached a pre-programmed value.

The resulting graph is a plot of potential vs. time.

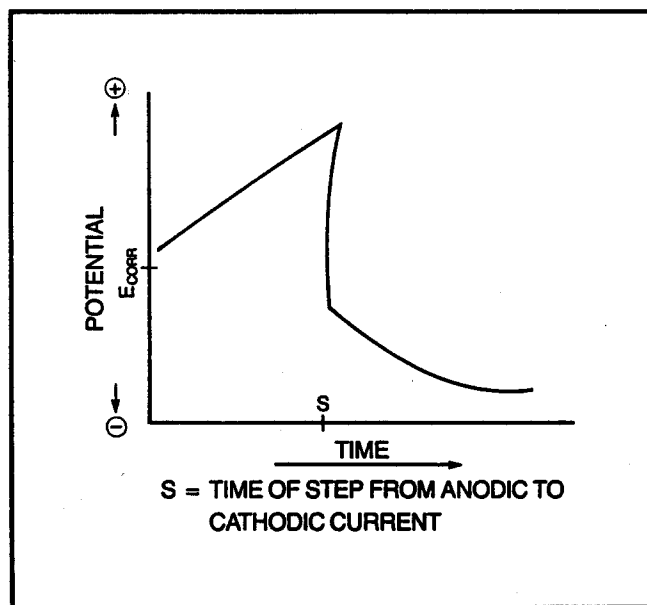

FIGURE 17. A hypothetical galvanostatic plot illustrating cathodic dissolution of a passive film.

Data Interpretation

Galvanostatic plots can be interpreted in a variety of ways, depending upon the physical and chemical behavior of the specimen at the initial and final current levels.

For example, if the data shown in Figure 17 represents a step from an anodic to a cathodic current level at the indicated step time, you could propose the following hypothesis:

- (1) At time zero the metal was unpassivated.
- (2) Exposure to the initial anodic current caused a passive film to be formed.

- (3) The step to the final cathodic current caused a reduction of the passive film.

You can confirm this hypothesis by holding a new (unpassivated) specimen at the same cathodic current density as the previous experiment. If the observed potential is similar to that observed in the last step of Figure 17, the hypothesis is confirmed.

Galvanodynamic

Purpose

When the controlled current approach is advantageous, the Galvanodynamic technique measures the corrosion rate and characterizes the general corrosion behavior of a specimen. Galvanodynamic scans can be used in place of their controlled potential counterparts: Polarization Resistance, Tafel Plot, Potentiodynamic, and Cyclic Polarization scans. The Galvanodynamic approach is preferred for systems which exhibit a rapidly changing, long term E_{CORR} drift.

Experimental Procedure

To program a cyclic Galvanodynamic scan, you specify an initial current, a vertex current, and a final current. If you want to begin the scan at the open circuit potential (E_{CORR}), specify the initial current as zero.

It is possible to perform cyclic Galvanodynamic scans where the vertex point is specified as either a current or a threshold potential value.

Data Interpretation

The data plots that result from Galvanodynamic scans are similar to those obtained by the corresponding Potentiodynamic techniques. Refer to the descriptions of the controlled potential techniques for an explanation of data interpretation.

Potentiokinetic Reactivation

Purpose

A Potentiokinetic Reactivation experiment determines the degree of sensitization of stainless steels due to heat treatment. This sensitization is caused by chromium-depletion zones in the intergranular structure when chromium carbide is formed.

Experimental Procedure

In a Potentiokinetic Reactivation experiment, you scan the potential beginning at +200 mV vs. the SCE reference electrode and continue in the negative direction to 50 mV negative of E_{CORR} (the open circuit potential).

Before the scan begins, you should passivate the specimen by holding the potential at +200 mV vs. the reference electrode for two minutes. You should program the scan rate for 1.66 mV/sec and use 0.5M H_2SO_4 + 0.01M KSCN electrolyte. The applied potential is plotted vs. the logarithm of the measured current.

Data Interpretation

You use a unique data interpretation method in the Potentiokinetic Reactivation technique. You integrate the current from the initial potential to E_{CORR} to determine the charge (Q) in coulombs (see Figure 19). You must also measure the grain boundary area (GBA), using ASTM E112 Standard Method for Estimating the Average Grain Size of Metals.

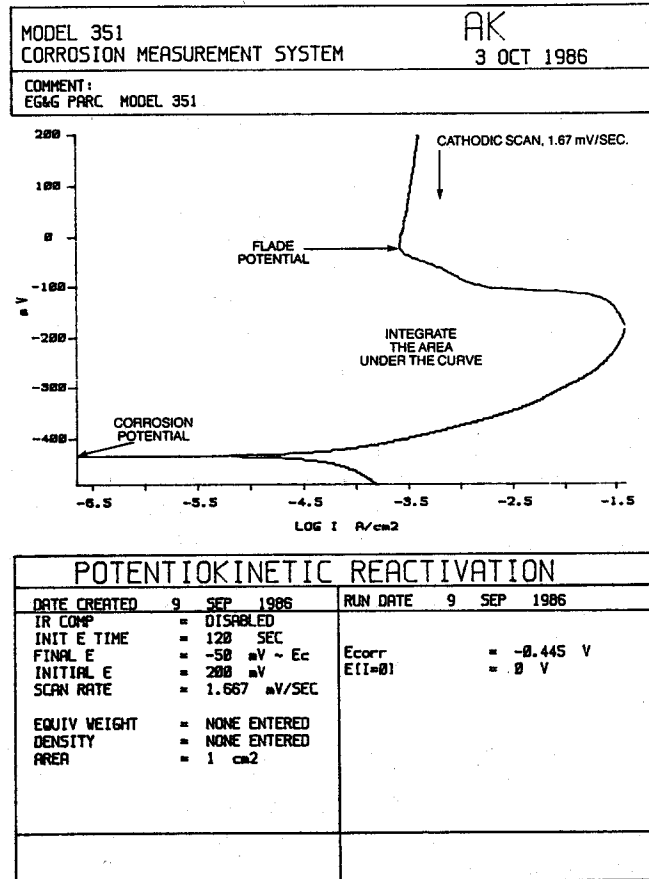

FIGURE 18. A typical potentiokinetic reactivation plot.

With the charge and the GBA, you can calculate the normalized charge per grain boundary area (Pa) using the following equation:

$$Pa = \frac{Q}{GBA}$$

A typical acceptance criteria for non-sensitized material is a Pa of 2.0 coulombs/cm². Higher values of Pa indicate sensitization has occurred to an unacceptable degree. If you like, you can determine additional acceptance criteria of your own by correlating Pa with failures observed in service.

Glossary

The following commonly used terms have been defined with respect to electrochemical corrosion techniques:

bridge tube—A component of the electrochemical test cell designed to physically isolate an electrode from the bulk of the electrolyte while maintaining an ionically conductive path to the test solution.

corrosion current—Current flow at the open circuit potential (E_{CORR}) as a result of discrete oxidation or reduction reactions. Notated as i_{CORR} . Related to the corrosion rate by the equation:

$$\text{Corrosion Rate (MPY)} = \frac{0.13 (i_{CORR}) (E.W.)}{A \cdot d}$$

where:

MPY = milli-inches per year

0.13 = metric and time conversion factor

E.W. = equivalent weight of specimen

d = density of specimen

A = surface area of specimen

corrosion potential—The equilibrium potential assumed by the specimen at open circuit (zero current flow). Notated as E_{CORR} .

corrosion rate—The calculated rate of specimen consumption due to homogeneous oxidation. Expressed in units of milli-inches or millimeters per year.

counter electrode—An inert conductive electrode which serves as a source or sink for electrons to enable current measurements.

electrolyte—An ionically conductive solution used as the medium in electrochemical measurements. In some corrosion experiments, the electrolyte is the corrosive environment itself. In other experiments, a solution simulates the corrosive environment (e.g., atmospheric corrosion).

pitting scan—An experiment in which the specimen potential is scanned in a cyclic manner while recording potential vs. log current. The resulting plot yields qualitative and rough quantitative information about the pitting tendencies of the specimen.

polarization resistance — 1. An experiment in which the specimen potential is scanned from 10-20 mV negative of E_{CORR} to 10-20 mV positive of E_{CORR} , while recording potential vs. current. The resulting curve can be used to determine the corrosion rate. Also called *linear polarization*. 2. The slope of the polarization resistance curve, given in units of ohms. Notated as R_p . The polarization resistance is related to the corrosion current (i_{CORR}) by the equation:

$$i_{CORR} = \frac{\beta_A \beta_C}{2.3 (\beta_A + \beta_C) R_p}$$

where:

β_A and β_C = anodic and cathodic Tafel Constants.

See *corrosion current* for the relation between i_{CORR} and the corrosion rate.

potentiodynamic anodic polarization scan—An experiment in which the potential is slowly scanned in the positive direction, while the potential vs. log current is recorded. The resulting data is useful for evaluating general corrosion and passivation behavior.

potentiostat—An electronic instrument that applies a controlled potential to the specimen while measuring the current flow at the specimen. Some modern potentiostats are capable of applying a controlled current, thus functioning as a *galvanostat* also.

reference electrode—An electrochemical half-cell, usually but not always a saturated calomel system. Assumes a stable potential which serves as a reference for the potential applied to the specimen.

Tafel Constant—The slope of the linear portion of the anodic or cathodic Tafel Plot curve (given in volts per decade of current). Notated as β_A or ATC (anodic Tafel Constant) or β_C or CTC (cathodic Tafel Constant).

Tafel Plot—An experiment in which the specimen is scanned from the open circuit potential (E_{CORR}) to a value of ± 250 mV vs. E_{CORR} , while the potential vs. the log current is recorded. The resulting curve can yield the Tafel Constants, which can be used to compute the corrosion rate.

uncompensated resistance—The electrical resistance between the specimen and the reference electrode in the test cell. Gives rise to *iR errors* if the instrument does not compensate.

vertex potential—The “turn-around” potential for a cyclic Potentiodynamic scan.

working electrode—Electrochemical term for the specimen.